



Steel construction project doors OD

Almost unlimited fitting options with the universal corner frame







4	Brand quality from Hörmann
6	Hörmann construction project door programme
8	Sustainable production
9	Architects' Program
10	Good reasons to try Hörmann
14	The right solutions for your requirements
16	Quality down to the last detail
18	Colours and designs
19	Tailor-made frame systems for your requirements
20	Universal corner frame
24	DryFix frame
26	2-part profile frame
28	Frame systems
30	Internal doors
40	External doors
44	Glazings, top parts and ventilation grilles
46	Special equipment
48	Door operator HDO 200 / 300
50	Overhead door closer
52	Lever handle sets
53	Anti-panic locks / door stop
54	Door sizing
55	Clear passage widths
56	Technical details
58	Hörmann product range

The colours and surface finishes shown are subject to the limitations of the printing process and cannot be regarded as binding.

All rights reserved. No part may be reproduced without our prior permission.
Subject to changes.

Brand quality from Hörmann

Top safety and reliability



State Ministry for Urban Development and the Environment in Hamburg with Hörmann products



In-house product development

Growing and constantly changing functional and safety requirements necessitate continuous new construction and equipment developments and improvements, especially when it comes to moveable construction components such as doors. In this area, our qualified development teams prove their highly specialised expertise time and again.



Highly sophisticated production methods

Hörmann relies on state-of-the-art production technology at highly specialised factories. Computer-controlled operations ensure dimensionally accurate elements with perfectly fitted fittings and functional parts.



Secure solutions with international approval

Hörmann provides you with all the doors you need from a single source. With a matching appearance and precisely the functions you require for your project – fire protection, smoke protection, acoustic insulation and burglar protection. Hörmann's expertise in fire protection is internationally approved. Several designs correspond to the "British Standard" and are thus approved for use in large parts of the Commonwealth. We also have approvals for China, where Hörmann manufactures fire-rated doors for the local market.

Established sales organisations are available within the corresponding countries for planning and implementation.

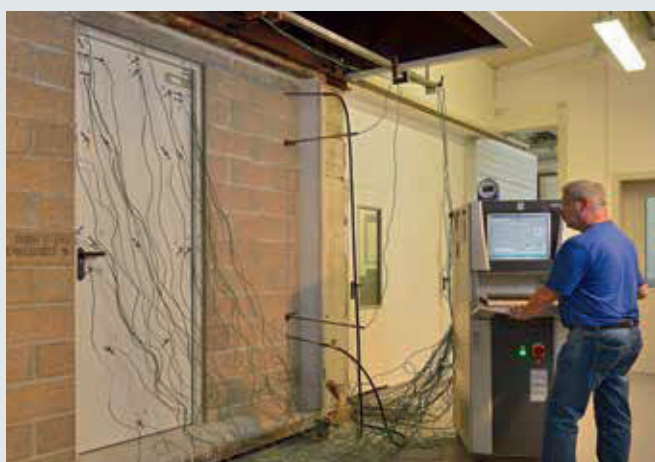

Fire testing at own fire test chamber

Our new and further developments are constantly tested for the required fire resistance and smoke-tightness through in-house fire tests at our fire testing centre. The knowledge gained from these tests ensures high fire protection for buildings. They also allow us to optimally prepare our innovations for the official inspections by accredited testing centres for official approvals.



Expert building support

Experienced specialists within our customer-oriented sales organisation accompany you from the planning stage, through technical clarification up to the final building inspection.

Expert fitting is guaranteed by experienced Hörmann fitters and the specialised trained staff of Hörmann's partners.

Hörmann construction project door programme

The right solution for any requirement





Steel doors

From sturdy steel internal doors and secure apartment entrance doors through to external doors with thermal break, Hörmann offers a large programme with diverse colour and equipment variants.



Steel and stainless steel construction project doors

Steel and stainless steel multi-function doors offer crucial advantages for architects and building owners: Doors with different functional requirements that are fitted in the same storey match perfectly thanks to their identical appearance. Steel and stainless steel doors STS/STU feature a flush-fitting, elegant appearance as well as impress with unlimited colour options and many frame variants.



Fully glazed tubular frame parts and automatic sliding doors

Hörmann's aluminium and steel fire-rated and smoke-tight doors and glazings in the T30, T60 and T90 models will convince you with certified safety, perfect function and a 100 % matching appearance. With Hörmann automatic sliding doors, you are combining the transparency of tubular frame parts with the requirements of fire protection or barrier-free construction. These products allow Hörmann to provide a uniform fire protection concept for use in architecturally demanding construction projects.

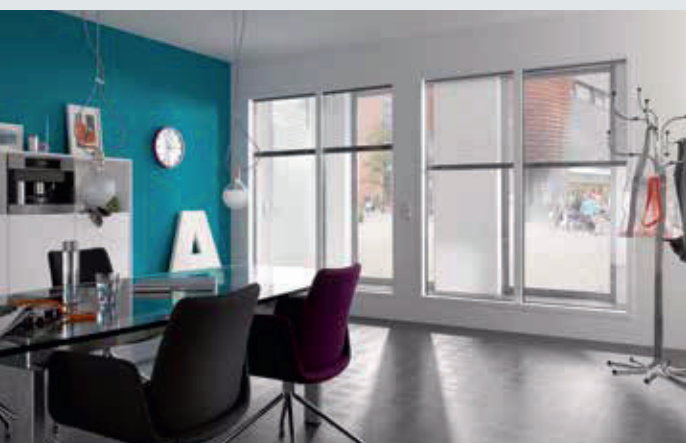

Visibility windows

Hörmann visibility glazings are used as windows or room-high elements to provide more light and better visibility. Visibility glazing is available for requirements such as thermal and acoustic insulation or radiation protection, as well as in fire-retarding F30 and fire-proof F90 variants. Individual solutions can be implemented using rail divisions, recesses and angles.

Image on left:
DC Tower in Vienna, with Hörmann products

Sustainable production

For trend-setting construction



Sustainability documented and approved by the ift in Rosenheim

Hörmann has received confirmation of sustainability for all steel construction project doors OD through an environmental product declaration (EPD)* in accordance with ISO 14025 from the Institut für Fenstertechnik (ift – Institute of window technology) in Rosenheim. The inspection was based on the Product Category Rules (PCR) Doors and Gates from ift Rosenheim GmbH, issue PCR-TT-0.1. Environmentally-friendly production was confirmed by a life-cycle analysis in accordance with DIN EN 14040 / 14044 for all doors.

Sustainably produced function doors from Hörmann

- **Environmentally-friendly production**
E.g. solvent-free powder coating at the factory, which can be fully finished on-site with a variety of limited-VOC paints or primers.
- **Regional raw materials**
The majority of applied raw materials is purchased from Germany and central Europe.
- **Durable, low maintenance products**
Approved in a functional test with more than 200000 closing cycles

Sustainable construction with Hörmann's expertise

Hörmann has been able to gain great expertise in sustainable construction through various projects. We also apply this know-how to support your projects.

Architects' Program

More than 9000 drawings for over 850 products



The Architects' Program

Planning with Hörmann products is now even easier thanks to a modern, user-friendly interface. Clearly structured navigation via drop-down menus and symbols, as well as a search function, give you faster access to tender specifications and drawings (in DWG and PDF format) of over 850 Hörmann products. **In addition, we provide you with BIM data from many products for the Building Information Modelling Process for the efficient planning, design, construction, and management of buildings.** Photos and photo-realistic presentations provide additional information on many products.



The Architects' Program is available to you as a web version at www.hoermann.co.uk/forums/architects-forum/architects-program or can be downloaded free-of-charge from the Hörmann Architects' Forum.

Advantages at a glance

- Tender specifications and drawings (DWG and PDF format) for over 850 Hörmann products
- Modern, user-friendly interface
- Clearly structured navigation with a search function
- Online and offline versions



We are a member of the professional association for digital building products in the Federal Association of Building Systems e.V.

Good reasons to try Hörmann

Matching system appearance for all functions



1

Door leaf glued over the entire surface

As a fully bonded composite construction **1**, the door leaf ensures **particularly high stability and leaf strength**. The door always closes securely and accurately with a satisfying noise.

2

High-quality appearance

Hörmann multi-function doors OD convince with their permanently flush surface. Their advantage: **Unevenness in the door leaf is virtually eliminated**. In double-leaf doors, the flush-fitting transition of the two door leaves forms a harmonious overall appearance.

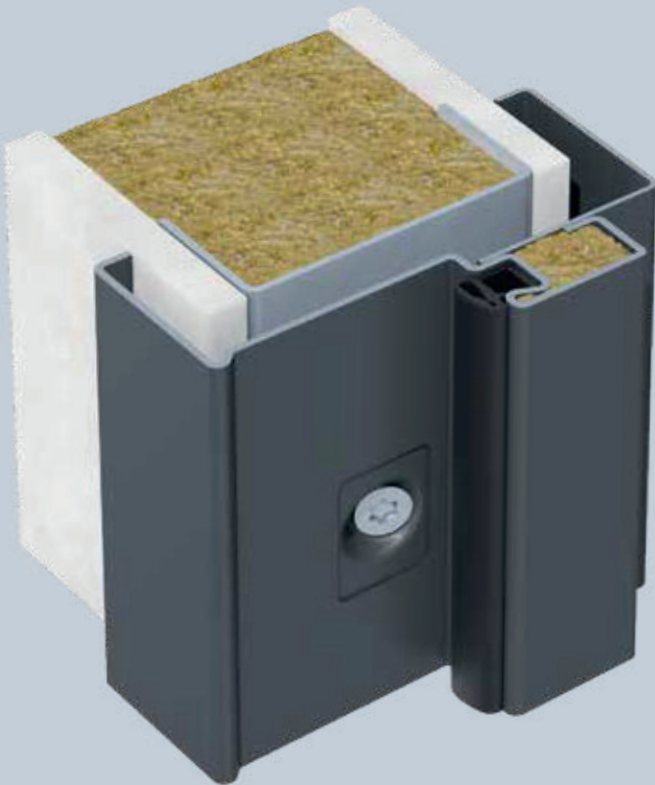

3

Universal corner frame

The universal corner frame is **ideal for various wall systems**: brickwork, gas concrete, concrete, partition wall (with counter frame). As standard, the frame with the diagonal fixing is screwed with the wall using the prefabricated holes in the frame. Alternatively, the frame can be fitted using the optional dowel brackets. **Flexibility for fitting** in the partition wall (also retrofitting) is provided by the counter frame B53 as well as the optional adapter for fitting with floor recess.



4

Developed today for the future

Steel construction project doors OD are designed in accordance with European fire protection requirements of **product standard EN 16034** as well as **tested according to DIN 4102 and EN 1634**. For you this means: After harmonisation of the product standard EN 16034, this replaces the country-specific approvals. **Only these European standards** and any relevant country-specific requirements **now apply when planning your fire-rated doors**. External doors are already delivered with a CE mark according to the product standard EN 14351-1.

Good reasons to try Hörmann

Matching system appearance for all functions



5

Internal and external doors

Internal and external doors have different requirements for fire protection and performance characteristics, such as wind load or water-tightness under heavy rain. The **fire protection functions of internal doors are subject to a test acc. to DIN 4102 and EN 1634**. External doors, however, close a wall opening on the building. As they are usually exposed to wind and weather, the **performance characteristics are tested according to EN 14351-1**. In the function as a fire-rated door, the additional product standard EN 16034 “Product standard, performance characteristics – Fire resistance and/or smoke control characteristics” is required.



6

Main and secondary functions

In addition to the main function of the steel construction project doors (e.g. fire protection), the functions can be **extended according to individual requirements**. Numerous additional performance characteristics are available to you. Equip your fire-rated door with break-in-resistant RC 2, RC 3 or RC 4 safety equipment, for example.



The tested burglar protection of our steel construction project doors is also recommended by police information centres.

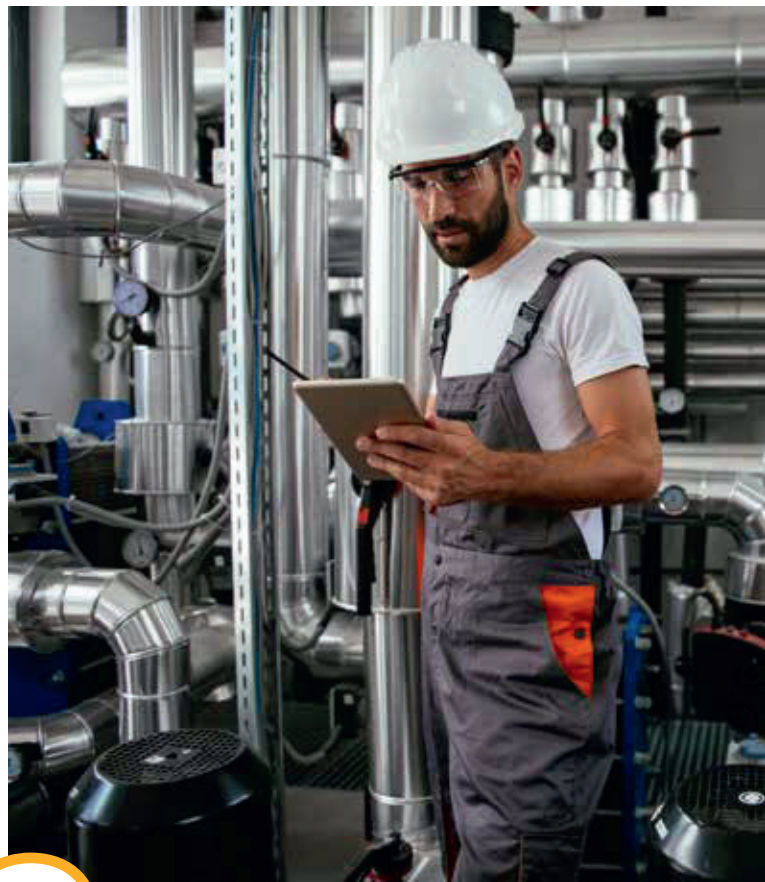

7

Barrier-free passages

Hörmann **automatic hinged doors allow barrier-free passage** and are universally applicable. Our construction project doors are already available from the factory with a suitable operator on request. You can conveniently operate the automatic doors by button, radar and movement detector, as well as **Hörmann operating elements with BiSecur radio technology**, such as the convenient hand transmitter, for example. Also, a door with a barrier-free overhead door closer is possible, which allows door opening with little effort.

8

Explosion protection

The term “ATEX” is the abbreviation of “ATmosphère EXplosible” and is usually used as a short name for the European Directive 2014/34/EU for explosion protection. This directive regulates the **use of products in potentially explosive atmospheres** and is intended, in particular, to protect people working in such environments. The specially equipped Hörmann steel construction project doors for ATEX areas **prevent sparking and electrostatic charging**, so that there is no danger of explosion from the door.

The right solutions for your requirements

Fire-retarding, smoke-tight, acoustic-rated, break-in-resistant

T30

EI₂30

T60

T90

EI₂90

RS

S₂₀₀

Fire-rated and smoke-tight doors

Smoke and fire damage can have considerable, even life-threatening results. It is therefore important to secure your premises with fire-rated and smoke-tight doors. It's a good thing that you can rely on Hörmann fire-rated and smoke-tight doors that are tested and officially approved.



dB

Acoustic-rated doors

Noise not only affects the concentration but can also cause stress and permanent illness. This is why it is important to insulate noise as much as possible in the area in which it occurs. With acoustic values up to 61 dB, Hörmann acoustic-rated doors considerably contribute to this.



RC 2

RC 3

RC 4

Security doors

Safety first! Hörmann break-in-resistant doors have been tested and certified in accordance with the European standards DIN V ENV 1627 to 1630 since 1999. Double-leaf security doors with resistance class RC 3 with anti-panic function according to EN 1125 reliably secure your emergency exits against break-in attempts.

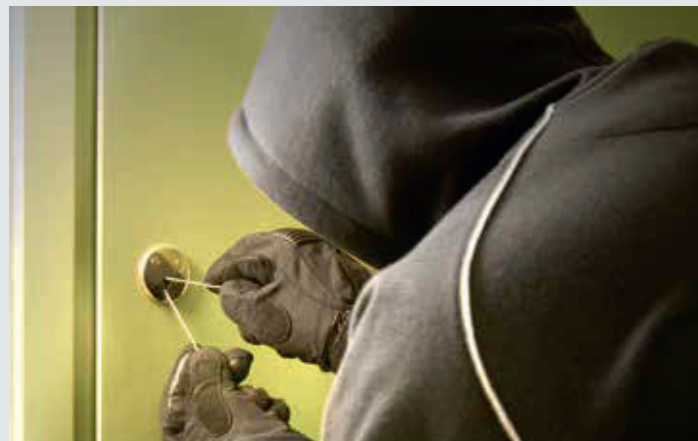

MZ

Multi-purpose doors

Whether for your warehouse or offices, indoors or outdoors, with or without special equipment – the large range of Hörmann multi-purpose doors complies with a multitude of requirements.

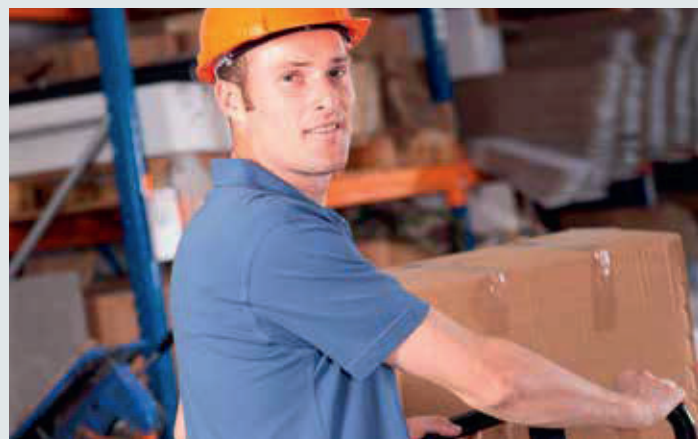

Door designation		H3 OD		H6 OD		H16 OD		D65 OD		H3 G		H3 VM		H16 G		HS 75		H16 S		D65		D65 VM	
		Single-leaf	Double-leaf	Single-leaf	Double-leaf	Single-leaf	Double-leaf	Single-leaf	Double-leaf	Single-leaf	Double-leaf	Single-leaf	Double-leaf	Single-leaf	Double-leaf	Single-leaf	Single-leaf	Single-leaf	Double-leaf	Single-leaf	Double-leaf	Single-leaf	Double-leaf
Internal doors		Page	31	32	33	34	36	36	37	38	39												
T30	T30 fire-retarding		■	■						■	■												
T60	T60 high fire resistance			■	■																		
T90	T90 fire-proof					■	■						■	■				■					
S₂₀₀	Smoke-tight		●	●	●	●	●	●	●	●		●											
RS	Smoke-tight									●		●		●	●								
dB	Acoustic rating		●	●	●	●	●	●	●												●	●	
dB	High acoustic rating														■	■							
RC 2	Break-in resistant, RC 2		●	●	●	●	●	●	●									●	●				
RC 3	Break-in resistant, RC 3		●	●		●		●	●														
RC 4	Break-in resistant, RC 4		●			●		●															
Ex	ATEX		●	●	●	●	●	●	●														
External doors		Page	41		42	43																	
EI₂30	EI ₂ 30 fire-retarding		■	■																			
EI₂60	EI ₂ 60 high fire resistance																						
EI₂90	EI ₂ 90 fire-proof				■																		
S₂₀₀	Smoke-tight		●	●		●																	
dB	Acoustic rating		●	●		●		●	●														
dB	High acoustic rating																						
RC 2	Break-in resistant, RC 2		●	●		●		●	●														
RC 3	Break-in resistant, RC 3		●	●		●		●	●														
RC 4	Break-in resistant, RC 4		●			●		●															
Ex	ATEX		●	●		●		●	●														

■ Main feature – as standard

● Additional function – optional with corresponding equipment

Quality down to the last detail

High-quality series equipment in all multi-function doors

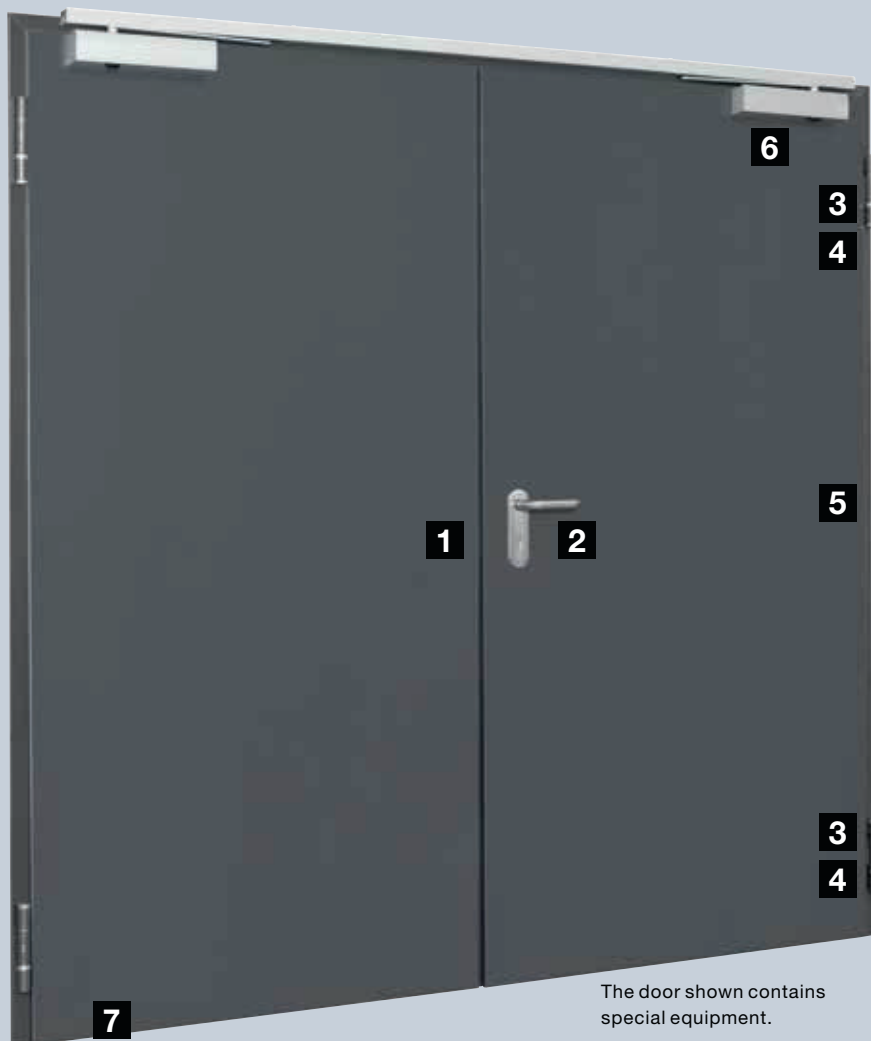

The door shown contains special equipment.

1 Securely locked

Hörmann steel construction project doors are equipped as standard with a high quality mortice lock with lever / knob and prepared for a profile cylinder. A robust rebate locking bolt or latch in rebate reliably secures the fixed leaf in double-leaf doors.

2 Stylish, high-quality lever handles

The FS round lever handle set is both convenient and stable, and is fitted to your multi-function door in a black polypropylene version as standard. A short escutcheon, a securely fitted lever handle and a deadlock insert with a key complete the high-quality standard equipment. Break-in-resistant doors are supplied with a FS security handle set made of aluminium, tested in accordance with EN 1906 / DIN 18257 class ES 1 (short escutcheon) or ES 2 / ES 3 (long escutcheon) with cylinder cover and drill-proof profile cylinder.

Rebate and door leaf on request

On request, Hörmann OD construction project doors are available in a thin rebate (standard) or thick rebate version. For an especially harmonious door appearance, we also offer doors with a flush-closing door leaf.



Thin rebate version



Thick rebate version



Flush version

3 Maintenance-friendly hinges

Our multi-function doors are equipped with 2 robust hinge sets with ball-bearing. Multi-function doors OD provide additional comfort: The maintenance-friendly rolling bearings on the door leaf can be easily and conveniently replaced.

4 Perfectly adjustable 3-way hinges

Use the optional and practical 3-way adjustable hinges to re-adjust your multi-function door. Even small fitting deviations can easily be compensated for. The 3-way adjustable hinges are also available with an inconspicuous spring hinge (depending on size and equipment). Fitting an overhead door closer can be omitted. The hinges are available in a galvanized powder-coated (as standard for high acoustic-rated and flush-closing doors) or a high-quality stainless steel version.

5 Sturdy security bolts

On fire-rated and smoke-tight doors, heavy-duty steel security bolts on the hinge side provide additional stability in the case of a fire. Break-in-resistant doors are protected against possible forced opening with up to 7 solid steel security bolts (depending on the resistance class).

6 Self-closing function as standard

The standard self-closing function makes every fire-rated or smoke-tight door a reassuring purchase. In single-leaf doors, the self-closing function is realised by a stable, robust spring hinge or Hörmann slide rail door closer HDC 35 (depending on equipment and size).

Double-leaf fire-rated and smoke-tight doors are equipped with a linkage door closer as standard (not shown). The mechanical door leaf selector ensures the correct locking sequence for both door leaves.

7 Optionally retractable bottom seal

The retractable bottom seal with delayed closing ensures easy door movement with simultaneously precise sealing. Due to optimum air and pressure compensation, doors in air locks and small rooms as well as doors on steps and pedestals can be safely closed.



Hinges with ball-bearing as standard



Easy replacement of roller bearings on the door leaf



Hörmann slide rail door closer HDC 35 as standard in single-leaf doors (depending on equipment and size)



Optional 3-way adjustable stainless steel hinges



Sturdy security bolts



Delayed, hydraulically retractable bottom seal (optional)

Colours and designs

Door design matching your property

For high-quality door appearances, we deliver all door leaves and frames galvanized with high-quality powder primer-coating in Grey white RAL 9002. Optionally, door leaves and frames are also available in RAL to choose or the door leaves are available with decor surface and optionally colour-matched frame (H3 OD, D65 OD).

Priming

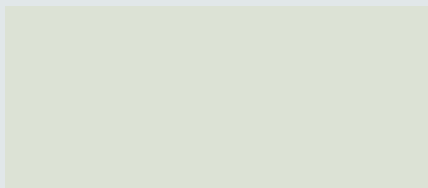

Grey white

RAL 9002

RAL to choose

We also supply all doors optionally in RAL to choose, metallic colours, or NCS colours.



All colours based on RAL.

6 preferred colours



Flame red

RAL 3000

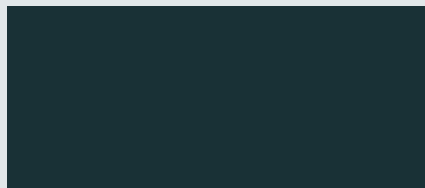

Anthracite grey

RAL 7016

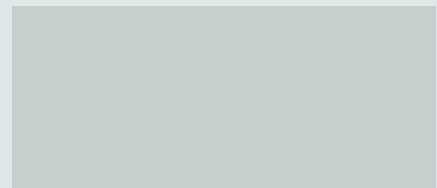

Light grey

RAL 7035



Grey aluminium

RAL 9007

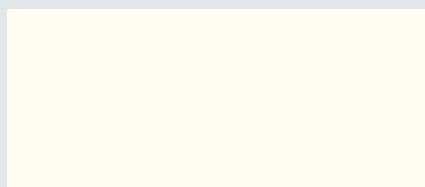

Pure white

RAL 9010

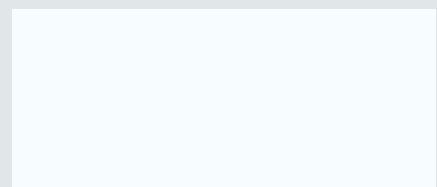

Traffic white

RAL 9016

Styles for H3 OD and D65 OD



Golden Oak



Dark Oak

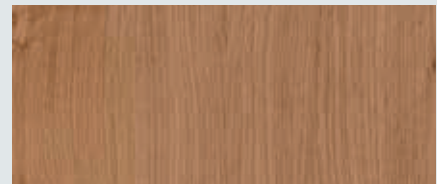

Winchester Oak

Tailor-made frame systems for your requirements

Flexible, versatile and quickly fitted

The Hörmann frame system guarantees a stable wall connection for optimal and long-lasting door functionality, providing the door leaf with the ideal framework: lasting quality, reliable stability and a high resistance. Individual frame solutions in genuine Hörmann quality are also available for your wall type.

Advantages at a glance:

- Sheet thickness 2 mm
- Moulded sealing groove
- As standard galvanized and with powder-coated primer in Grey white (similar to RAL 9002)
- Optionally in RAL to choose
- Simple and fast fitting via diagonal fixing or fixing brackets including steel spacers

Lining groove

Steel frames for multi-function doors are equipped with a special lining groove as standard. This means that bonding the seals is not necessary.



Edge guard

All doors that are not provided with lock plates at the factory are equipped with an edge guard made of high-quality plastic as standard. This effectively protects the priming or the on-site coating. In addition, the door closes more quietly.



Flush-fitting cover caps

In frames that are fitted in the reveal, flush-fitting cover caps ensure the attractive appearance of the frame. They can be painted over and thus completely hidden.



Unpainted frame

Universal corner frame

With almost unlimited fitting options

With the new universal corner frame you can fit the construction project doors OD faster, easier and more flexibly. The frame is quickly fitted with just a few screw connections using diagonal fixing as standard. Using optional fitting packages, the frame can be easily adapted to different installation situations – with or without floor recess, plug-and-screw fitting, as a corner or 2-part profile frame (extension by counter frame).

This makes it an **ideal stock frame**, because only a few components are required in addition to the **door set** for fitting in all wall types:

- Counter frame Vario B53 (as a compact 3-part frame pack)
- Adapter for floor recess
- Dowel brackets
- Plug and screw sets for individual wall types
- Mineral wool shaped parts

The universal corner frame is suitable for fitting in the following wall types:

- Brickwork
- Concrete
- Gas concrete
- Partition wall

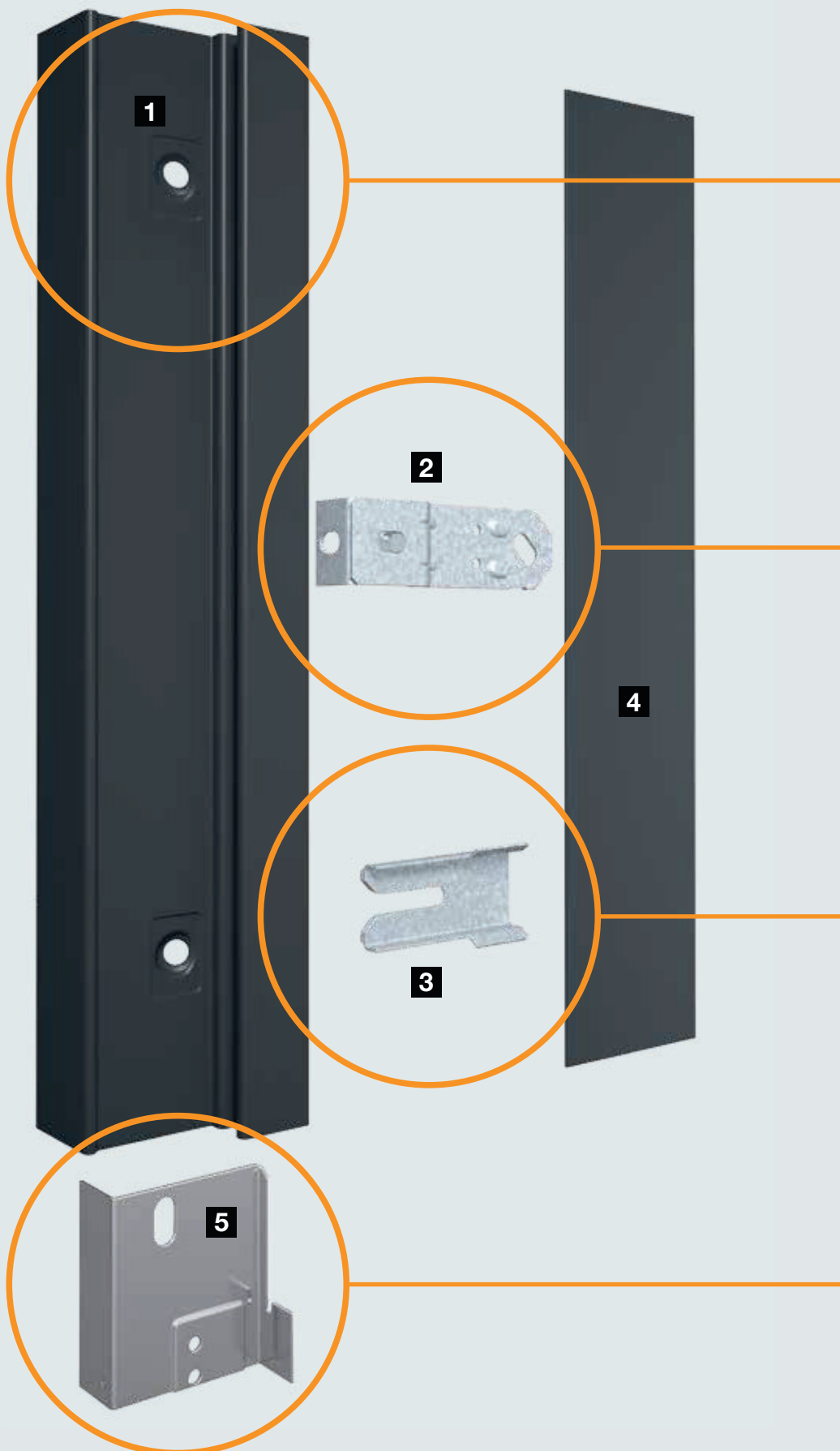



Exterior view

Standard fitting by diagonal fixing **1**

With diagonal fixing, the frame is screwed to the wall using the prefabricated holes. Fitting is quick and easy with only 3 fixing points per side (up to a door height of 1250 × 2250 mm). Standard fixing brackets **3** and spacers make fitting and adjustment of the door easier. Subsequently, the screw hole is covered flush-fitting with a self-adhesive plate.



Interior view

Alternative fitting with optional dowel brackets **2**

The optionally available fitting packs also allow the frame to be traditionally fitted with dowel brackets. The dowel brackets are simply attached to the available threaded bolts. The dowel brackets are available as a short version for unplastered brickwork and as a long version for plastered walls.



Interior view

Possible extension as a 2-part profile frame using an optional counter frame **4**

The counter frame Vario B53 (up to wall width 270 mm) is subsequently pushed under the universal corner frame. It is fixed with the standard fixing brackets (spacers) **3** of the corner frame and possibly with additional clamping brackets. Further fastenings and a backfill of the counter frame are generally not required. Another advantage: The variable wall width (-5 mm to +15 mm) means that wall tolerances up to 20 mm can be compensated.



Interior view

Optional stainless steel adapter **5** for fitting with floor recess

The universal corner frame is supplied without floor recess as standard. If fitting is to be carried out with floor recess, simply screw the optional stainless steel adapters to the frame.

Universal corner frame

For fitting to brickwork, concrete, gas concrete and partition walls

Brickwork / concrete

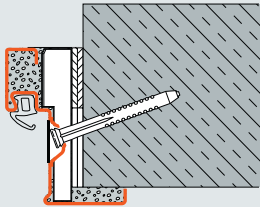

Diagonal fixing
(Unplastered brickwork / concrete)

Gas concrete

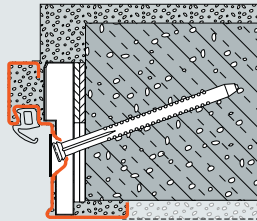

Diagonal fixing
(Gas concrete)

Partition wall

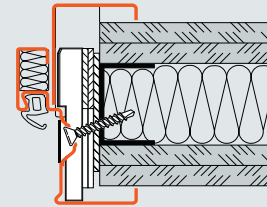

Diagonal fixing
With counter frame Vario B53
as a 2-part profile frame
(Partition wall F90 A)

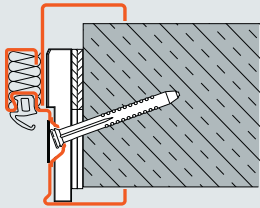

Diagonal fixing
With counter frame Vario B53
as a 2-part profile frame
(Unplastered brickwork / concrete)

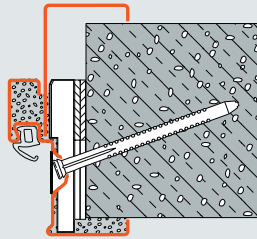

Diagonal fixing
With counter frame Vario B53
as a 2-part profile frame
(Gas concrete)



DryFix frame

For easy, fast and clean fitting



The ready-made frame

The Hörmann DryFix frame is the ideal solution for simple, quick and clean fitting. The advantage: The frame is fully prepared at the factory and already backfilled with mineral wool. This saves up to 50 % of the required fitting time at the construction site. Diagonal fixing with only one 100 mm (160 mm for gas concrete) anchoring screw per fixing point ensures maximum frame stability. The concealed fastening holes in the frame rebate are covered with cover caps and are invisible when the door is closed. Fitting without mortar is optimal for unplastered brickwork, as the risk of soiling or damaging the frame or brickwork is minimised. The DryFix frame is particularly suitable for fitting to existing structures since it can easily be retrofitted.



See the fitting video at:
<http://www.hoermann.co.uk/videos>



Place the frame in the opening and align it



Tighten the frame



Seal the connection gap and cover up the fastening holes

Simply made into a VarioFix Fire frame

The DryFix frame is made into a VarioFix Fire frame by using the Vario B36 counter frame. It is connected using the DryFix frame fixing brackets. The VarioFix Fire frame is already backfilled with mineral wool at the factory. Another advantage: With the counter frame, wall unevenness of up to 20 mm can be compensated.



VarioFix Fire frame

DryFix frame
Optimum for fitting
to unplastered brickwork



Brickwork / concrete

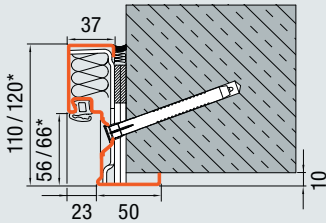

DryFix frame with diagonal fixing
(Unplastered brickwork / concrete)

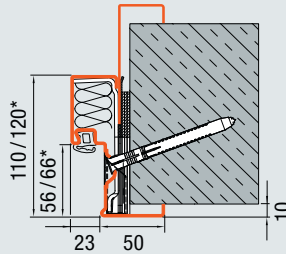

VarioFix Fire
(Brickwork / concrete)

Gas concrete

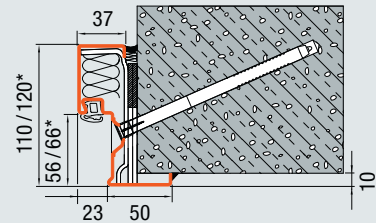

DryFix frame with diagonal fixing
(Gas concrete)

Partition wall

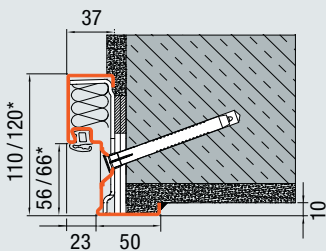

DryFix frame with diagonal fixing
(Plastered brickwork)

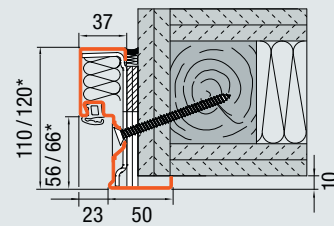

DryFix frame with diagonal fixing
(F90 B timber partition walls)

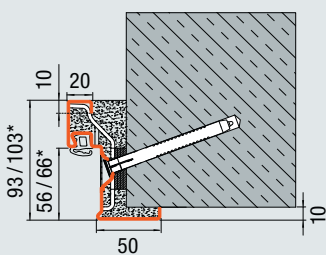

Corner frame with diagonal fixing
(Brickwork / unplastered brickwork / concrete)

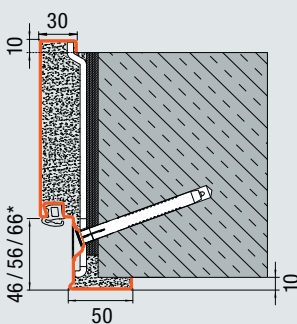

Profile frame with diagonal fixing
(Brickwork)

All dimensions in mm

* Depending on the door leaf thickness and rebate type

2-part profile frame

For concealed fitting

2-part profile frame with concealed screw-fixing

The double-shell profile system is particularly suitable for retrofitting. It is fastened to the partition wall via 8 fixing points (in single-leaf doors), with one screw each. First, only corner frame profile 1 is mounted. After this step, the door leaf can be adjusted so that it is optimally fitted to the seal. This is particularly advantageous for doors featuring smoke protection, acoustic insulation or thermal insulation functions. Only then is counter frame profile 2 mounted. Next, the two frame profiles are fastened with screws concealed in the sealing groove. The screw is covered by the sealing. With a frame depth of 76 mm opposite the hinge side, the frame can be filled with mineral wool on-site. You can optionally receive suitably shaped parts from the factory.



Place corner frame profile 1 of the frame in the opening and align it



Screw corner frame profile 1 to the partition wall

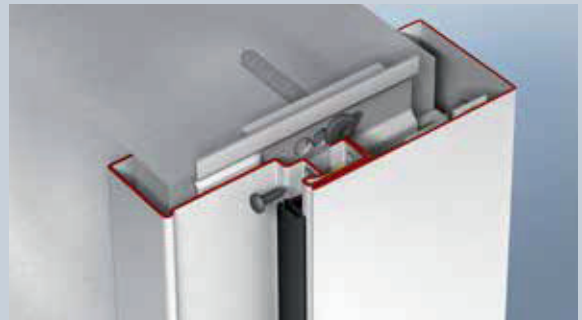

Screw counter frame profile 2 of the frame to profile 1 through the sealing groove and cover with the door sealing

Brickwork / concrete

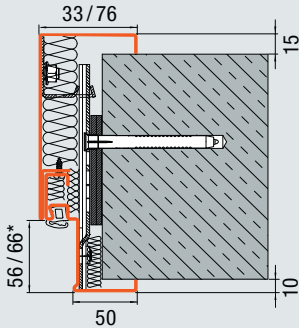

2-part profile frame with concealed plug-and-screw fitting and mineral wool backfilling (Brickwork / unplastered brickwork / concrete, also for plastered brickwork)

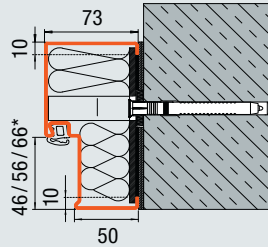

Block frame with flush-fitting cover caps as concealed plug-and-screw fitting in the opening (Brickwork / concrete)

Partition wall

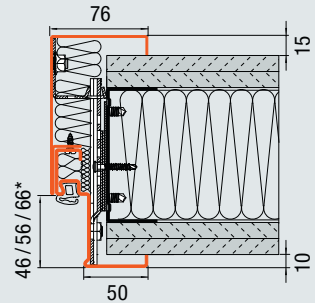

2-part profile frame with concealed plug-and-screw fitting and mineral wool backfilling (partition wall) F90 A and F90 B (shown: F90 A)

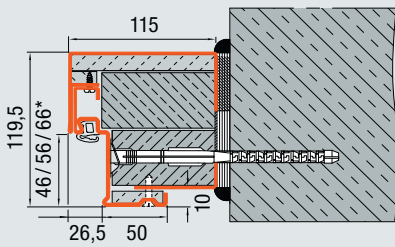

Double-shell block frame with increased frame depth and concealed plug-and-screw fitting (Brickwork / concrete)

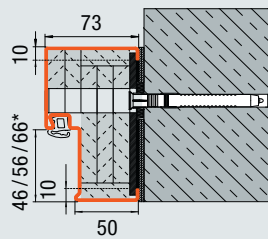

Block frame with flush-fitting cover caps as concealed plug-and-screw fitting (Brickwork / concrete)

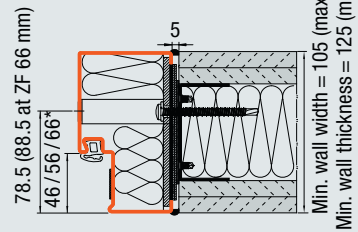

Block frame with flush-fitting cover caps as concealed plug-and-screw fitting in the opening (partition wall)

Min. wall width = 105 (max. 180)
Min. wall thickness = 125 (max. 200)

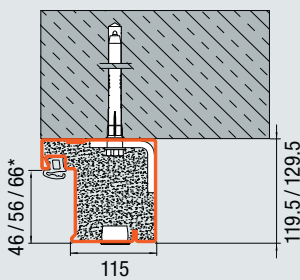

Block frame with flush-fitting cover caps as concealed plug-and-screw fitting in front of the opening (Brickwork / max. T30 doors)

All dimensions in mm

* Depending on the door leaf thickness and rebate type

Frame systems

For all application areas

Brickwork / concrete

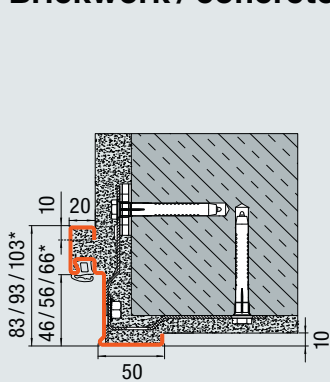

Corner frame with plug-and-screw fitting
(Brickwork / concrete)

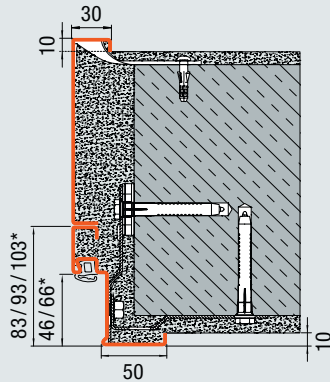

Corner and counter frame with plug-and-screw fitting
(Brickwork / concrete)

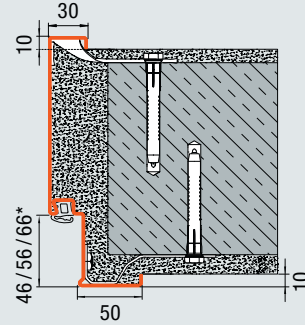

Profile frame with plug-and-screw fitting
(Brickwork / concrete)

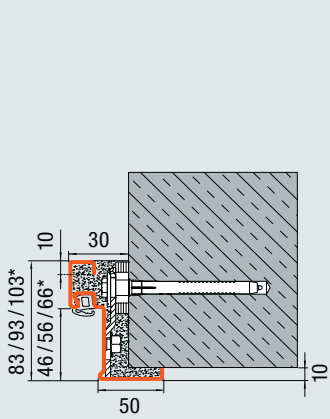

Corner frame with concealed plug-and-screw fitting
(Unplastered brickwork / concrete)

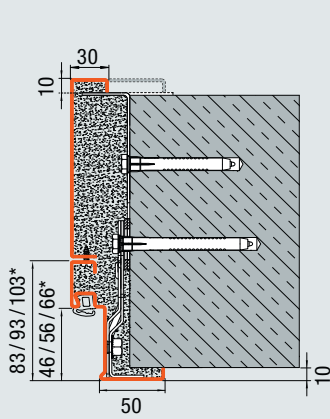

Corner and counter frame with concealed plug-and-screw fitting and counter frame with fitting by welding
(Unplastered brickwork / concrete)

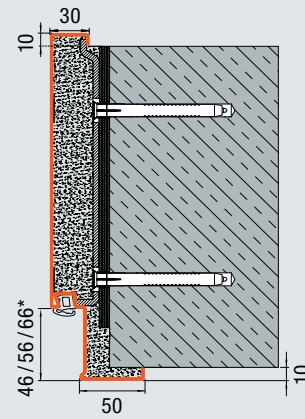

Profile frame with plug-and-screw fitting through the frame reveal
(unplastered brickwork / concrete)

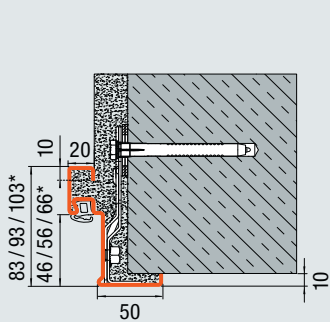

Corner frame with plug-and-screw fitting in the reveal
(Brickwork / concrete)

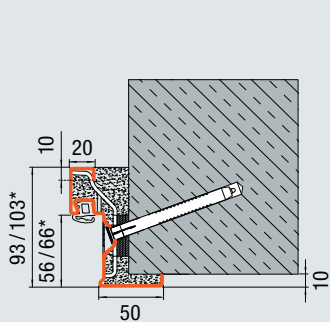

Corner frame with diagonal fixing
(Brickwork / unplastered brickwork / concrete)

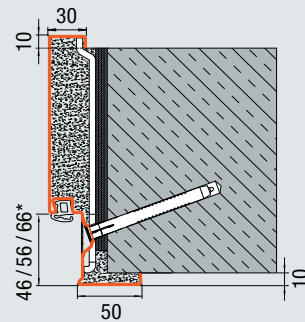

Profile frame with diagonal fixing
(Brickwork)

Gas concrete

Partition wall

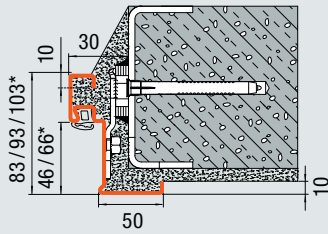

Corner frame with fitting by welding
(Gas concrete)

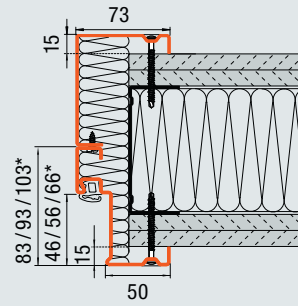

Corner and counter frame with screw-fixing
(Partition wall)

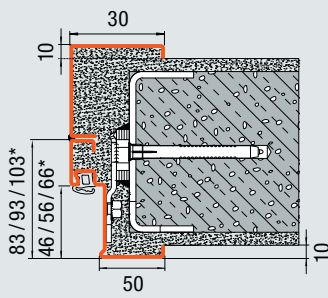

Corner and counter frame
with fitting by welding
(Gas concrete)

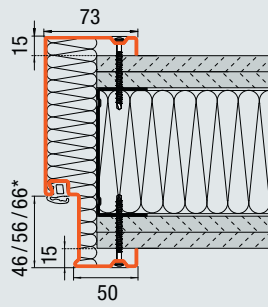

Profile frame with screw-fixing
(Partition wall)

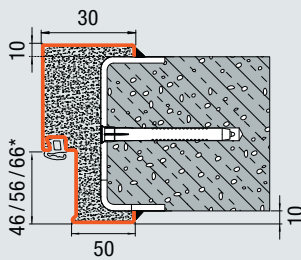

Profile frame with fitting by welding
(Gas concrete)

All dimensions in mm

* Depending on the door leaf thickness and rebate type

Internal doors

Corresponding to European product standards EN 16034 and EN 14351



T30 fire-rated door H3 OD

Single-leaf and double-leaf internal door



Thin rebate
Door leaf thickness
65 mm



Thick rebate
Door leaf thickness
65 mm



Flush
Door leaf thickness
59 mm

Main feature

Fire-retarding

T30

EI₂30

Additional performance characteristics

(with corresponding equipment)

Smoke-tight

S₂₀₀

Acoustic rating

Acoustic values from
32 – 43 dB

dB

Break-in-resistant

Thin rebate / thick rebate: not in combination with glazing and top part

RC 2

RC 3

RC 4

In approval process: depending on the door version, available as H3-1



Decor surfaces
As thick rebate

With universal corner frame as standard

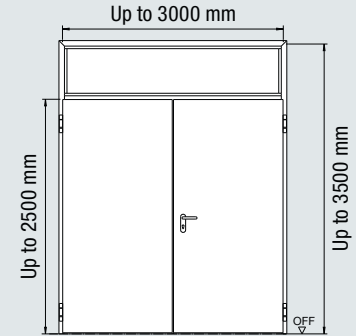
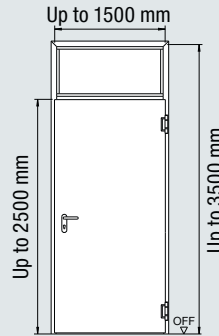
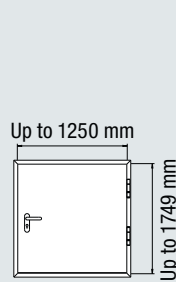

Fire-rated door

Construction:

Door leaf

Sheet thickness

Rebate type

H3-1 OD

Fully bonded composite construction

65 – 59 mm

1.0 / 1.5 mm

Thin rebate / thick rebate / flush

H3-2 OD

Fully bonded composite construction

65 – 59 mm

1.0 / 1.5 mm

Thin rebate / thick rebate / flush

Fitting in

Brickwork

≥ 115 mm / ≥ 175 mm*

≥ 115 mm / ≥ 175 mm*

Concrete

≥ 100 mm / ≥ 140 mm*

≥ 100 mm / ≥ 140 mm*

Gas concrete blocks

≥ 150 mm

≥ 175 mm

Gas concrete slabs

≥ 150 mm

≥ 175 mm

Prefabricated walls according to DIN 4102-4, tab. 48

≥ 100 mm

≥ 100 mm

Prefabricated walls according to DIN 4102-4, tab. 49

≥ 130 mm

≥ 130 mm

Additional performance characteristics

Acoustic insulation

32 – 43 dB

32 – 43 dB

Thermal insulation value

1.5 W/(m²·K)

1.5 W/(m²·K)

Break-in resistance

RC 2, RC 3, RC 4

RC 2, RC 3

Optional extras

Glazings	Page 44
Top parts	Page 44
Decor surfaces	Page 18
Special equipment	Page 46
Door sizing	Page 54

Size range	H3-1 OD		H3-2 OD	
	Width	Height	Width	Height
Nominal size (ordering size)	500 – 1500	500 – 2500	1375 – 3000	1750 – 2500
With fixed top part		– 3500		– 3500
Traffic leaf width			750 – 1500	
Fixed leaf width			500 – 1500	

All dimensions in mm

T60 fire-rated door H6 OD

Single-leaf and double-leaf
internal door

NEW



Thin rebate
Door leaf thickness
65 mm



Thick rebate
Door leaf thickness
65 mm

Main feature

High fire resistance

T60

Additional performance characteristics

(with corresponding equipment)

S₂₀₀

Smoke-tight

dB

Acoustic rating

Acoustic values
from 32 – 39 dB

RC 2

Break-in-resistant

Not in combination
with glazing

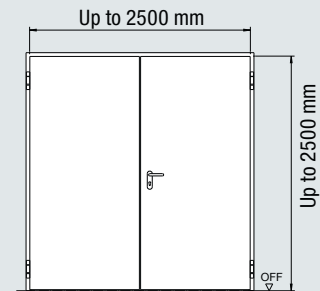
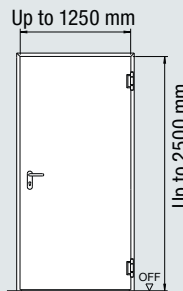

Fire-rated door

Construction:

Door leaf

Sheet thickness

Rebate type

Fitting in

Brickwork ≥ 175 mm
Concrete ≥ 120 mm
Gas concrete blocks ≥ 175 mm
Gas concrete slabs ≥ 175 mm
Prefabricated walls according to
DIN 4102-4, tab. 48 ≥ 100 mm

H6-1 OD

Fully bonded composite construction

65 mm

1.0 / 1.5 mm

Thin / thick rebate

≥ 175 mm

≥ 120 mm

≥ 175 mm

≥ 175 mm

≥ 100 mm

H6-2 OD

Fully bonded composite construction

65 mm

1.0 mm

Thin / thick rebate

≥ 175 mm

≥ 140 mm

≥ 175 mm

≥ 175 mm

≥ 125 mm

Additional performance characteristics

Thermal insulation value on request on request
Acoustic insulation 32 – 33 dB 36 – 39 dB

Optional extras

Glazings	Page 44
Top parts	Page 44
Special equipment	Page 46
Door sizing	Page 54

Size range	H6-1 OD		H6-2 OD	
	Width	Height	Width	Height
Nominal size (ordering size)	625 – 1250	1750 – 2500	1375 – 2500	1750 – 2500
Traffic leaf width			750 – 1250	
Fixed leaf width			500 – 1250	

All dimensions in mm

T90 fire-rated door H16 OD

Single-leaf and double-leaf internal door



Thin rebate
Door leaf thickness
65 mm



Thick rebate
Door leaf thickness
65 mm

Main feature

Fire-proof

T90

EI₂90

Additional performance characteristics

(with corresponding equipment)

S₂₀₀

Smoke-tight

dB

Acoustic rating
Acoustic values
from 35 – 42 dB

RC 2

Break-in-resistant
Not in combination
with glazing
and top part

RC 3

Not in combination
with glazing
and top part

RC 4

In approval process:
depending on the door
version, available
as H16-1

**With universal corner
frame as standard**

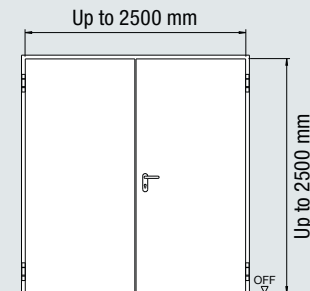
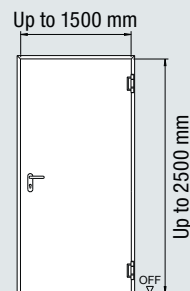
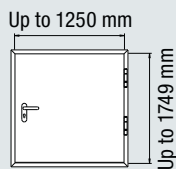

Fire-rated door

Construction:

Door leaf

Sheet thickness

Rebate type

H16-1 OD

**Fully bonded composite
construction**

65 mm

1.0 / 1.5 mm

Thin / thick rebate

H16-2 OD

**Fully bonded composite
construction**

65 mm

1.0 mm

Thin / thick rebate

Fitting in

Brickwork	≥ 175 mm	≥ 175 mm
Concrete	≥ 140 mm	≥ 140 mm
Gas concrete blocks	≥ 200 mm	≥ 200 mm
Gas concrete slabs	≥ 200 mm	≥ 200 mm
Prefabricated walls according to DIN 4102-4, tab. 48	≥ 125 mm	≥ 125 mm
Prefabricated walls according to DIN 4102-4, tab. 49	≥ 125 mm	≥ 125 mm

Additional performance characteristics

Acoustic insulation	35 – 42 dB
Thermal insulation value	1.5 W/(m ² ·K)
Break-in resistance	RC 2, RC 3, RC 4

Optional extras

Glazings	Page 44
Top parts	Page 44
Special equipment	Page 46
Door sizing	Page 54

Size range	H16-1 OD		H16-2 OD	
	Width	Height	Width	Height
Nominal size (ordering size)	500 – 1500	500 – 2500	1375 – 2500	1750 – 2500
Traffic leaf width			750 – 1250	
Fixed leaf width			500 – 1250	

All dimensions in mm

Multi-function door

D65 OD

Single-leaf and double-leaf internal door



Thin rebate

Door leaf thickness
65 mm



Thick rebate

Door leaf thickness
65 mm



Flush

Door leaf thickness
59 mm

Main feature

Multi-purpose door

MZ

Additional performance characteristics

(with corresponding equipment)

dB

Acoustic rating

Acoustic values
from 32 – 43 dB

S₂₀₀

Smoke-tight

Single-leaf
and double-leaf

RC 2

Break-in-resistant

Thin / thick rebate:
Not in combination
with glazing
and top part

RC 3

RC 4

In approval process:
depending on the door
version, available
as E65-1



Decor surfaces

As thick rebate

With universal corner
frame as standard

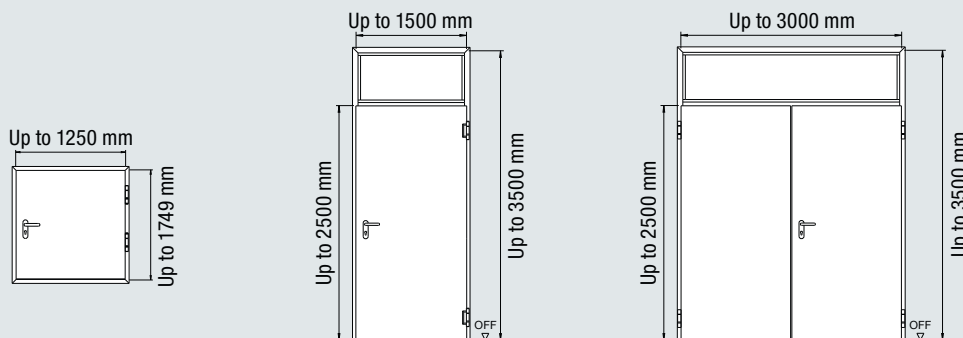

Multi-function door

Construction:

Door leaf

Sheet thickness

Rebate type

Fitting in

Brickwork

Concrete

Gas concrete blocks

Gas concrete slabs

Prefabricated walls according to DIN 4102-4, tab. 48

Prefabricated walls according to DIN 4102-4, tab. 49

Additional performance characteristics

Acoustic insulation

Thermal insulation value

Break-in resistance

D65-1 OD

Fully bonded composite construction

65 – 59 mm

1.0 / 1.5 mm

Thin rebate / thick rebate / flush

≥ 115 mm

≥ 100 mm

≥ 150 mm

≥ 150 mm

≥ 100 mm

≥ 130 mm

32 – 43 dB

1.5 W/(m²·K)

RC 2, RC 3, RC 4

D65-2 OD

Fully bonded composite construction

65 – 59 mm

1.0 / 1.5 mm

Thin rebate / thick rebate / flush

≥ 115 mm

≥ 100 mm

≥ 175 mm

≥ 175 mm

≥ 100 mm

≥ 130 mm

32 – 43 dB

1.5 W/(m²·K)

RC 2, RC 3

Size range	D65-1 OD		D65-2 OD	
	Width	Height	Width	Height
Nominal size (ordering size)	500 – 1500	500 – 2500	1375 – 3000	1750 – 2500
With fixed top part		– 3500		– 3500
Traffic leaf width			750 – 1500	
Fixed leaf width			500 – 1500	

Optional extras

Glazings	Page 44
Top parts	Page 44
Decor surfaces	Page 18
Special equipment	Page 46
Door sizing	Page 54

Office building at Rödingsmarkt, Hamburg
Architect: Bothe Richter Teherani, Hamburg



Hörmann products

- T30 steel fire-rated doors H3
- T90 steel fire-rated doors H16
- T30 steel fire-rated doors STS
- T30 aluminium fire-rated doors HE 311



T30 fire-rated door

H3 G / H3 VM

Single-leaf and double-leaf internal door, oversize



Thin rebate

Door leaf thickness
65 mm



Thick rebate

Door leaf thickness
65 mm

Main feature

Fire-retarding

T30

Additional performance characteristics

(with corresponding equipment)

RS

Smoke-tight

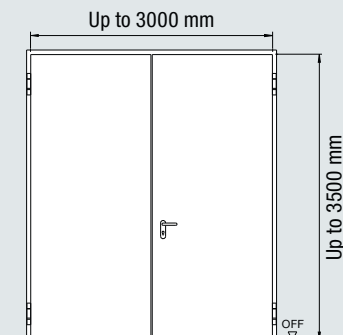
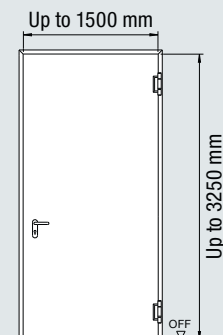

Fire-rated door

Construction:

Door leaf

Sheet thickness

Rebate type

H3 G-1

Welded design

65 mm

1.5 mm

Thin rebate

H3-2 VM

Welded design

65 mm

1.5 mm

Thin / thick rebate

Fitting in

Brickwork

≥ 175 mm

≥ 175 mm

Concrete

≥ 140 mm

≥ 140 mm

Gas concrete blocks

≥ 175 mm

≥ 175 mm

Gas concrete slabs

≥ 175 mm

≥ 175 mm

Prefabricated walls according to DIN 4102-4, tab. 48

≥ 100 mm

≥ 100 mm

Additional performance characteristics

Thermal insulation value

2.0 W/(m²·K)

1.6 W/(m²·K)

Optional extras

Glazings	Page 44
Top parts	Page 44
Special equipment	Page 46
Door sizing	Page 54

Size range	H3 G-1		H3-2 VM	
	Width	Height	Width	Height
Nominal size (ordering size)	875 – 1500	2500 – 3250	1375 – 3000	1750 – 3500
With fixed top part				
Traffic leaf width			1000 – 1500	
Fixed leaf width			500 – 1500	

All dimensions in mm

T90 fire-rated door H16 G

Single-leaf and double-leaf internal door, oversize



Thin rebate
Door leaf thickness
65 / 78 mm

Main feature

T90

Fire-proof

Additional performance characteristics

(with corresponding equipment)

RS

Smoke-tight
H16 G-1

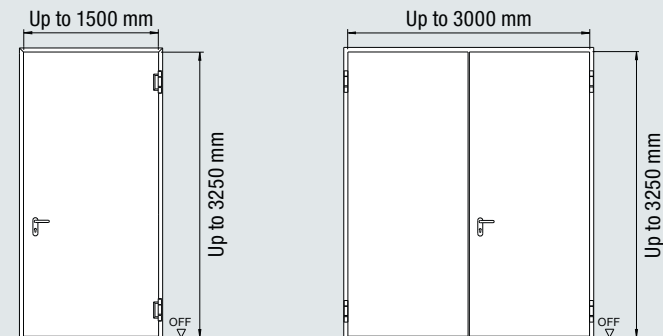

Fire-rated door

Construction:

Door leaf

Sheet thickness

Rebate type

H16 G-1

Welded design

65 mm

1.5 mm

Thin rebate

H16 G-2

Welded design

78 mm

1.5 mm

Thin rebate

Fitting in

Brickwork	≥ 240 mm	≥ 240 mm
Concrete	≥ 140 mm	≥ 140 mm
Gas concrete blocks	≥ 200 mm	≥ 200 mm
Gas concrete slabs	≥ 200 mm	≥ 200 mm
Prefabricated walls according to DIN 4102-4, tab. 48	≥ 100 mm	-

Additional performance characteristics

Thermal insulation value 1.8 W/(m²·K)

Optional extras

Glazings	Page 44
Top parts	Page 44
Special equipment	Page 46
Door sizing	Page 54

Size range	H16 G-1		H16 G-2	
	Width	Height	Width	Height
Nominal size (ordering size)	875 – 1500	2500 – 3250	1500 – 3000	2000 – 3250
Traffic leaf width			1000 – 1500	
Fixed leaf width			500 – 1500	

All dimensions in mm

Acoustic-rated door HS 75 / H16 S

Single-leaf

High acoustic rating
up to 61 dB



Thick rebate
Door leaf thickness
75 mm

Main feature

dB

High acoustic rating
Acoustic values
from 50 – 61 dB

Additional performance characteristics

(with corresponding equipment)

T90

Fire-proof
H16 S

RS

Smoke-tight
H16 S

RC 2

Break-in-resistant

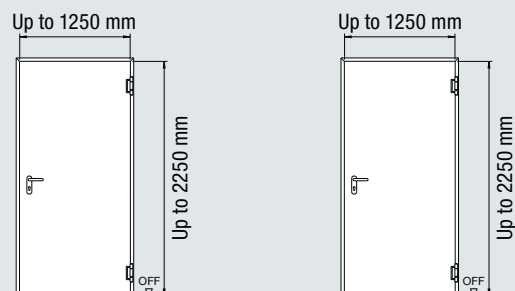

Acoustic-rated door

Construction:

Door leaf

Sheet thickness

Rebate type

HS75-1

Welded design

75 mm

1.0 mm

Thick rebate

H16 S-1

Welded design

75 mm

1.0 mm

Thick rebate

Fitting in

Brickwork

≥ 115 mm

≥ 175 mm

Concrete

≥ 100 mm

≥ 120 mm

Additional performance characteristics

Acoustic rating category

IV

V

IV

V

With threshold rail with seal and 2 retractable bottom seals

-

53 dB

-

53 dB

With 2 retractable bottom seals

50 dB

-

50 dB

-

With threshold rail with seal

51 dB

-

51 dB

-

For increased requirements, acoustic rating category VI

With 2 retractable bottom seals

59 dB

-

59 dB

-

With 2 aluminium bottom profiles with seal with stepped threshold

59 dB

-

59 dB

-

With threshold rail with seal

61 dB

-

61 dB

-

Door bottom edges

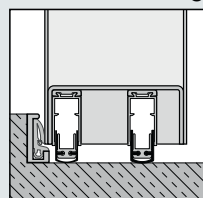

Threshold rail with seal and 2 retractable bottom seals

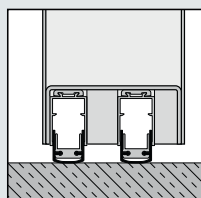

2 retractable bottom seals

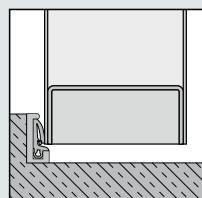

Threshold rail with seal

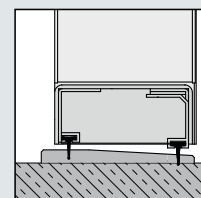

Stepped threshold with seal

Optional extras

Glazings	Page 44
Top parts	Page 44
Special equipment	Page 46
Door sizing	Page 54

Size range	HS75-1		H16 S-1	
	Width	Height	Width	Height
Nominal size (ordering size)	625 – 1250	1750 – 2250	625 – 1250	1750 – 2250

All dimensions in mm

Steel door D65 / D65 VM

Single-leaf and double-leaf internal door



Thin rebate
Door leaf thickness
65 mm

Main feature

Multi-purpose door

MZ

Additional performance characteristics

(with corresponding equipment)

dB

Acoustic rating

Acoustic values
from 38 – 45 dB

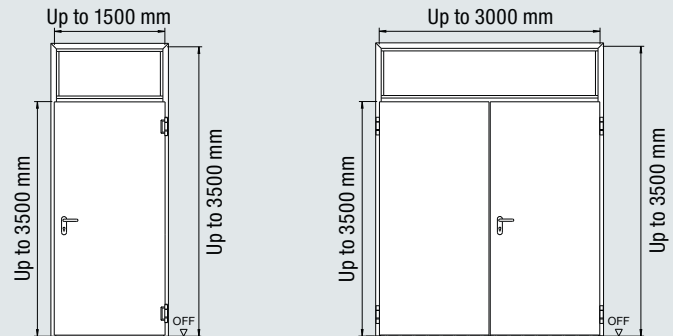

Multi-function door

Construction:

Door leaf

Sheet thickness

Rebate type

D65-1

Welded design

65 mm

1.5 mm

Thin rebate

D65-2 VM

Welded design

65 mm

1.5 mm

Thin rebate

Fitting in

Brickwork	●	●
Concrete	●	●
Gas concrete blocks	●	●
Gas concrete slabs	●	●
Prefabricated walls according to DIN 4102-4, tab. 48	●	●
Prefabricated walls according to DIN 4102-4, tab. 49	●	●

Additional performance characteristics

Acoustic insulation	38 – 45 dB	
Thermal insulation value	1.8 W/(m ² ·K)	1.8 W/(m ² ·K)

Optional extras

Glazings	Page 44
Top parts	Page 44
Special equipment	Page 46
Door sizing	Page 54

Size range	D65-1		D65-2 VM	
	Width	Height	Width	Height
Nominal size (ordering size)	625 – 1500	2500 – 3500	1250 – 3000	2500 – 3500
With fixed top part		– 3500		– 3500
Traffic leaf width			750 – 1500	
Fixed leaf width			500 – 1500	

All dimensions in mm

External doors

Approved performance characteristics acc. to EN 14351-1



EI₂30 fire-rated door

H3 OD

Single-leaf and double-leaf external door



Thin rebate
Door leaf thickness
65 mm



Thick rebate
Door leaf thickness
65 mm

Main feature

EI₂30

Fire-retarding

Sa

Sealed

C5

Self-closing
200000 cycles

Additional performance characteristics

(with corresponding equipment)

S₂₀₀

Smoke-tight

dB

Acoustic rating
Acoustic values from
32 – 43 dB

RC 2

Break-in-resistant
Not in combination
with glazing
and top part

RC 3

RC 4

In approval process:
supplied as H3-1

With universal corner
frame as standard

Optional extras

Glazings	Page 44
Special equipment	Page 46
Door sizing	Page 54

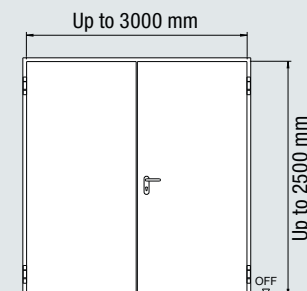
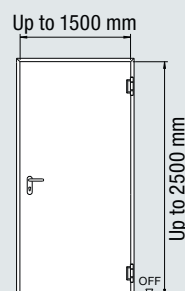
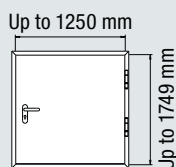

Fire-rated door

Construction:

Door leaf

Sheet thickness

Rebate type

H3-1 OD

Fully bonded composite construction

65 – 59 mm

1.0 / 1.5 mm

Thin / thick rebate

H3-2 OD

Fully bonded composite construction

65 – 59 mm

1.0 / 1.5 mm

Thin / thick rebate

Fitting in

Brickwork	≥ 115 mm / ≥ 175 mm*	≥ 115 mm / ≥ 175 mm*
Concrete	≥ 100 mm / ≥ 140 mm*	≥ 100 mm / ≥ 140 mm*
Gas concrete blocks	≥ 150 mm	≥ 175 mm
Gas concrete slabs	≥ 150 mm	≥ 175 mm

Additional performance characteristics

Self-locking	C5	C5
Resistance to wind load	Class C3	Class C2
Water tightness under heavy rain		
Opening inwards	Unprotected 3A	Protected 2B
Opening outwards	Unprotected 3A / protected 7B	Protected 2B or 5B
Acoustic insulation	32 – 43 dB	32 – 43 dB
Thermal insulation value	1.5 W/(m ² ·K)	1.5 W/(m ² ·K)
Air permeability	2	2
Impact resistance	200	
Break-in resistance	RC 2, RC 3, RC 4	RC 2, RC 3
Operating forces	2	2
Mechanical strength	4 (2 for glazing)	4 (2 for glazing)
Differential climate behaviour	2(d) / 1(e)	

Size range	H3-1 OD		H3-2 OD	
	Width	Height	Width	Height
Nominal size (ordering size)	500 – 1500	500 – 2500	1375 – 3000	1750 – 2500
Traffic leaf width			750 – 1500	
Fixed leaf width			500 – 1500	

All dimensions in mm

El₂90 fire-rated door H16 OD

Single-leaf external door



Thin rebate
Door leaf thickness
65 mm



Thick rebate
Door leaf thickness
65 mm

Main feature

El₂90

Fire-proof

Sa

Sealed

C5

Self-closing
200000 cycles

Additional performance characteristics

(with corresponding equipment)

S₂₀₀

Smoke-tight

dB

Acoustic rating
Acoustic values from
35 – 42 dB

RC 2

Break-in-resistant
Not in combination
with glazing

RC 3

Not in combination
with glazing

RC 4

In approval process:
depending on the door
version, available
as H16-1

**With universal corner
frame as standard**

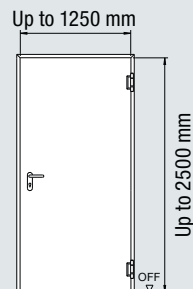
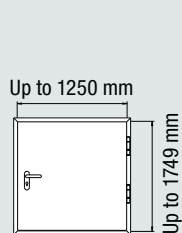

Fire-rated door

Construction:

Door leaf

Sheet thickness

Rebate type

H16-1 OD

**Fully bonded composite
construction**

65 mm

1.0 / 1.5 mm

Thin / thick rebate

Fitting in

Brickwork	≥ 175 mm
Concrete	≥ 140 mm
Gas concrete blocks	≥ 200 mm
Gas concrete slabs	≥ 200 mm

Additional performance characteristics

Self-locking	C5
Acoustic insulation	35 – 42 dB
Thermal insulation value	1.5 W/(m ² ·K)
Break-in resistance	RC 2, RC 3, RC 4

Optional extras

Glazings	Page 44
Special equipment	Page 46
Door sizing	Page 54

Size range	H16-1 OD	
	Width	Height
Nominal size (ordering size)	500 – 1250	500 – 2500
Traffic leaf width		
Fixed leaf width		

Multi-function door D65 OD

Single-leaf and double-leaf external door



Thin rebate
Door leaf thickness
65 mm



Thick rebate
Door leaf thickness
65 mm

Main feature

Multi-purpose door

MZ

Additional performance characteristics

(with corresponding equipment)

dB

Acoustic rating
Acoustic values
from 32 – 43 dB

S₂₀₀

Smoke-tight
Single-leaf
and double-leaf

RC 2

Break-in-resistant
Thin / thick rebate:
Not in combination
with glazing
and top part

RC 3

RC 4

In approval process:
depending on the door
version, available
as E65-1

With universal corner
frame as standard

Optional extras

Glazings	Page 44
Special equipment	Page 46
Door sizing	Page 54

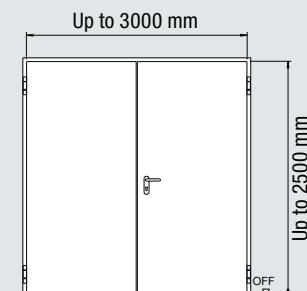
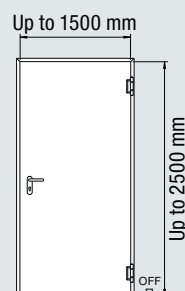
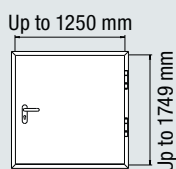

Multi-function door

Construction:

Door leaf

Sheet thickness

Rebate type

D65-1 OD

Fully bonded composite construction

65 mm

1.0 / 1.5 mm

Thin / thick rebate

D65-2 OD

Fully bonded composite construction

65 mm

1.0 / 1.5 mm

Thin / thick rebate

Fitting in

Brickwork	≥ 115 mm	≥ 115 mm
Concrete	≥ 100 mm	≥ 100 mm
Gas concrete blocks	≥ 150 mm	≥ 175 mm
Gas concrete slabs	≥ 150 mm	≥ 175 mm

Additional performance characteristics

Self-locking	C5	C5
Resistance to wind load	Class C3	Class C2
Water tightness under heavy rain		
Opening inwards	Unprotected 3A	Protected 2B or 5B
Opening outwards	Unprotected 3A / protected 7B	
Acoustic insulation	32 – 43 dB	32 – 43 dB
Thermal insulation value	1.5 W/(m ² ·K)	1.5 W/(m ² ·K)
Air permeability	2	2
Impact resistance	200	
Break-in resistance	RC 2, RC 3, RC 4	RC 2, RC 3
Operating forces	2	2
Mechanical strength	4 (2 for glazing)	4 (2 for glazing)
Differential climate behaviour	2(d) / 1(e)	

Size range	D65-1 OD		D65-2 OD	
	Width	Height	Width	Height
Nominal size (ordering size)	500 – 1500	500 – 2500	1375 – 3000	1750 – 2500
Traffic leaf width			750 – 1500	
Fixed leaf width			500 – 1500	

All dimensions in mm

Glazings, top parts and ventilation grilles

For more light and ventilation



Steel profile in Grey white



Stainless steel profile

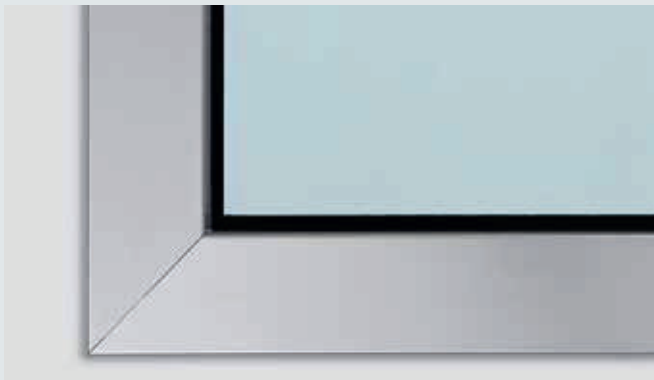

Aluminium cover profile

Aluminium or steel glazing frame

As standard, glazing profiles are supplied in galvanized steel, with powder-coated primer in Grey white (similar to RAL 9002). On request, the profiles are also available in brushed stainless steel and rectangular glazing with aluminium cover profiles anodised with a natural finish (F1).

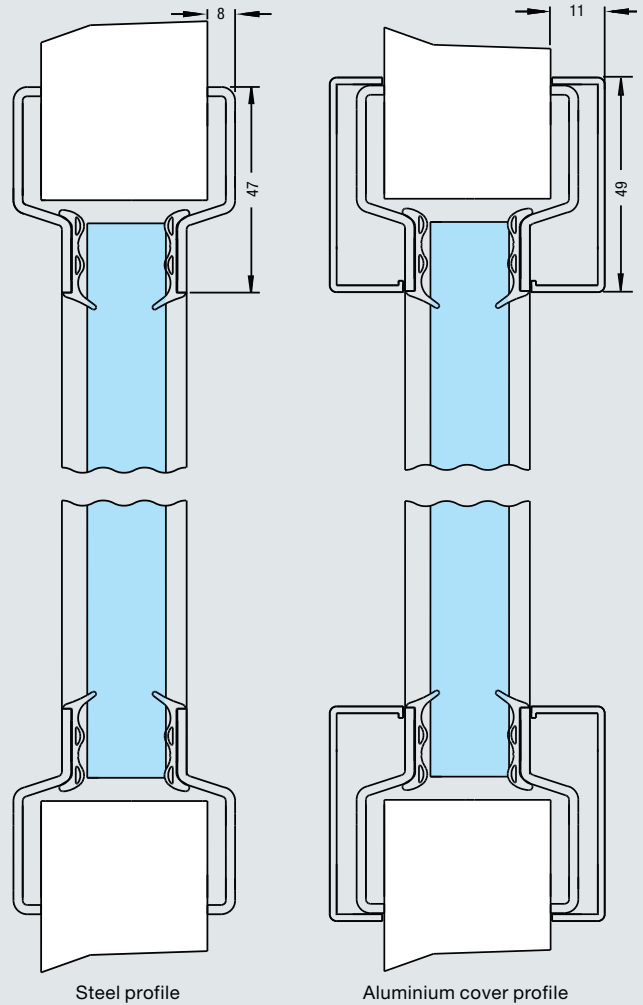

Glazing view 0

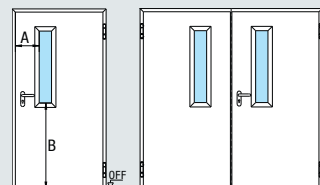

Glazing view 1

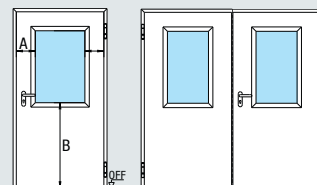

Glazing view 2

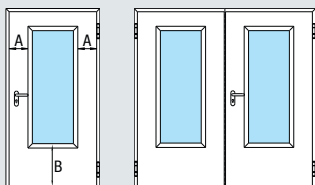

Glazing view 3

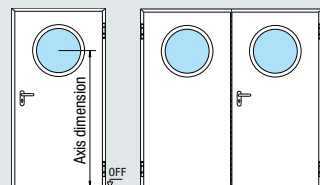

Round glazing

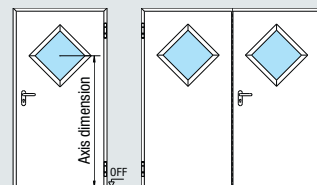

Diamond-shaped glazing

Special glazing available on request

In addition to the glazing referred to on the left we also supply special single or multi-pane glazing in various shapes and arrangements within the permitted distance to side, bottom section height and glazing size.



Fixed top parts

The top parts allow you to individually design room-high doors for your facility. You benefit from a harmonious door appearance thanks to continuous frame profiles.

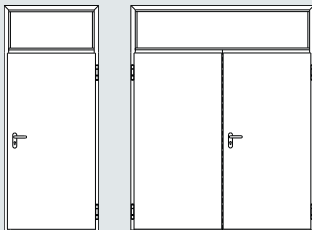

With steel panel

Height Min. 250 mm
Max. 1000 mm

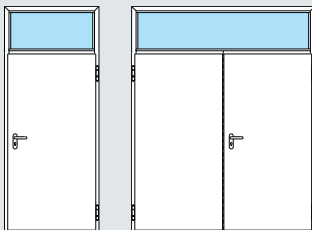

With glazing

Height Min. 250 mm
Max. 1000 mm

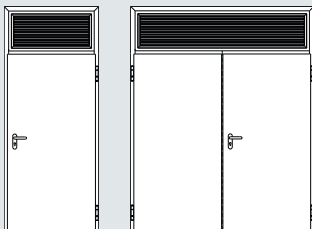

With ventilation grille

Height Min. 250 mm
Max. 1000 mm

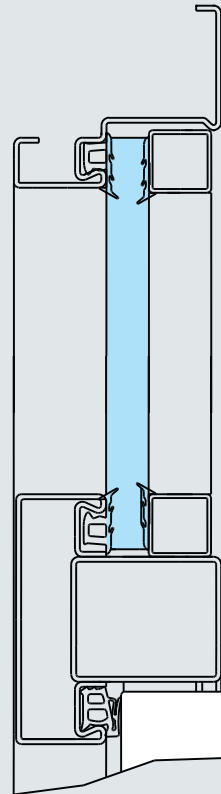

Top part

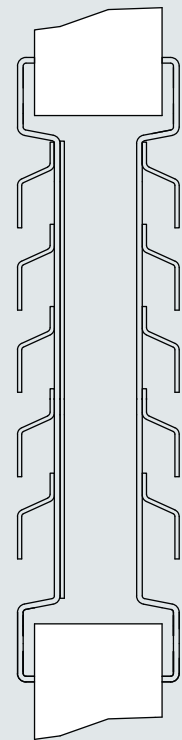

Ventilation grilles



Ventilation grilles

All ventilation grilles consist of safety sheet metal with an internal perforated steel sheet. They are supplied galvanized and with powder-coated primer in Grey white (similar to RAL 9002).

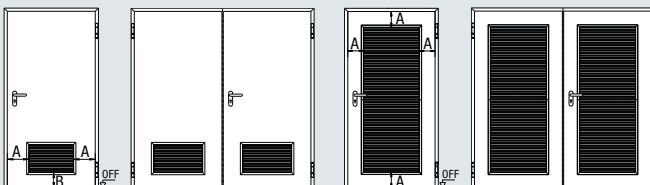

Grille height: 365 mm

Distance to side A: 220 mm

Bottom section height B: 180 mm

Special equipment

For barrier-free construction, an exclusive appearance and increased comfort





Locks

In addition to the normal use of a door, the facility often requires special lock functions or additional locks.

Optional special and additional locks:

- Anti-panic locks or locks with escape door function with different functions
- Double cylinder lock (locked with 2 different cylinders)
- Bolt lock, additionally prepared for profile cylinder
- Block lock
- Motor lock
- Self-locking escape door lock



Electrical equipment

In the facility, door assemblies are often equipped with alarm, escape-route security or access control systems. Various components are available according to your needs:

- Latch contact
- Reed contact
- Electric door strike
- Escape door opener
- Alarm wire mesh
- Motor lock
- Door lock
- Electronic alarm contact elements
- Concealed electro duct



Emergency exit locks

Specific hardware and lock fittings are required for escape doors according to DIN EN 179 and DIN EN 1125. Hörmann offers you a wide range of different equipment variants for your respective needs.

Emergency exit locks according to DIN EN 179

- Fittings in the form of anti-panic or lever/knob handle sets with short or rose escutcheon with matching handles
- Lock with escape door function DIN EN 179
- Lock with self-locking or motorised escape door function

Anti-panic locks acc. to DIN EN 1125

- Fittings with push bar or touch bar combined with a variety of lever handle sets approved acc. to DIN EN 1125
- Anti-panic lock DIN EN 1125 with different functions
- Up to RC 3 (double-leaf) or RC 4 (single-leaf)

Door operator HDO 200 / 300

Perfectly matched system – door and operator from a single source

*25 % less expensive
than similar operators*



Hörmann automatic hinged doors with operator HDO 200 / HDO 300 can be used in universal applications. Thanks to their quiet operation, they are particularly suitable for hospitals and offices. In addition, the automatic doors feature convenient opening, allowing for barrier-free passage. Speed control ensures a uniform opening and closing speed. An integrated programme switch allows for custom settings. You can conveniently operate the automatic door via a button, radar / movement detector or operating elements with BiSecur radio technology.

Door and operator from a single source

The door and operator are supplied as a perfectly matching all-in-one system, including the necessary fitting material, from a single source. This simplifies and accelerates door fitting and commissioning.



HDO 300 with Flatscan protection sensor

- Convenient opening for barrier-free passages
- Quiet operation, therefore suitable for various applications, e.g. in offices or hospitals
- Speed control ensures a uniform opening and closing speed
- Operating modes: “automatic”, “permanently open”, “night”, “closing time”
- Integrated programme switch for “off”, “automatic” and “permanently open”
- Operation via buttons, radar / motion detector, etc.
- Optionally with BiSecur radio technology that can be operated via all Hörmann hand transmitters, radio control elements, radio internal push buttons or the BiSecur app

	HDO 200	HDO 300
Width	650 mm	720 mm
Height	70 mm	70 mm
Depth	121 mm	130 mm
Weight	9 kg	11 kg
Door width	750 – 1400 mm	800 – 1600 mm
Door height	Up to 2500 mm	Up to 2500 mm
Door weight	Up to 200 kg	300 kg for 1400 mm door width 210 kg for 1600 mm door width



Flatscan protection sensor for automatic hinged doors

- Safeguarding the main and secondary closing edges
- Safeguarding through laser technology (light travel time measurement)
- With 170 measurement points
- Compact dimensions of 143 × 85 mm

Overhead door closer

The right solution for every requirement



Overhead door closer HDC 35

With compensator function, smoke sensor control or electromechanical hold-open device – Hörmann offers the right overhead door closer with the corresponding equipment for every door situation. The products convince not only in terms of quality and comfort, but also design, e.g. with the flush view of slide rail and closing mechanism in many versions.

Overhead door closer	HDC 35	TS 4000	TS 83	TS 5000	EC-Line	ILSM	E	E-FS	R	R-FS	E-ISM	R-ISM
Linkage door closer		●	●									
Slide rail door closer	●			●	●	●	●	●	●	●	●	●
Integrated door closer												
With restrained opening		●		●								
With compensator function								●		●		
With optimum passage convenience (Barrier-free acc. to DIN 18010 / DIN SPEC 1104)					●							
With integrated door leaf selector for double-leaf doors						●					●	●
With electromechanical hold-open device							●				●	
With electromagnetic hold-open device									●			●
With smoke sensor control									●	●		●



Overhead door closer TS 4000



Overhead door closer TS 5000



Overhead door closer TS 83



Overhead door closer TS 93 / TS 99



Integrated overhead door closer ITS 96

TS 93	GSR	EMF / EMR	GSR EMF2	GSR EMR2	TS 99 FL	FLR	ITS 96	GSR	EML	FL
●	●	●	●	●	●	●				
							●	●	●	●
●										
					●	●				●
	●		●	●	●	●		●		
		●	●	●	●	●			●	
		●		●		●				

Lever handle sets

In line with your individual wishes



Design FS lever handle set D-810

As standard, Hörmann steel and stainless steel doors come with a black plastic handle with round rose escutcheon and are prepared for a profile cylinder. Object lever handle sets made of aluminium or stainless steel are also optionally available.

Design FS lever handle set D-810 / D-830

With object ball-bearing in stainless steel
Version in design D-810, D-830 with anti-panic DIN EN179 and further design types

FS lever handle set D-110 suitable acc. to EN 179

With object sliding bearing in aluminium or stainless steel
With object ball-bearing in stainless steel

FS lever handle set D-190 (XXL lever handle) suitable acc. to DIN 18040

With object sliding bearing in stainless steel

FS lever handle set D-210

With object sliding bearing in aluminium or stainless steel

FS lever handle set D-310

With object sliding bearing in aluminium or stainless steel
With object ball-bearing in stainless steel

FS lever handle set D-330 suitable acc. to EN 179

With object sliding bearing in aluminium or stainless steel
With object ball-bearing in stainless steel

FS lever handle set D-410 suitable acc. to EN 179

With object sliding bearing in aluminium or stainless steel
With object ball-bearing in stainless steel

FS lever handle set D-490 (XXL lever handle) suitable acc. to DIN 18040

With object ball-bearing in stainless steel

FS lever handle set D-510 suitable acc. to EN 179

With object sliding bearing in aluminium or stainless steel
With object ball-bearing in stainless steel



FS lever handle set D-110

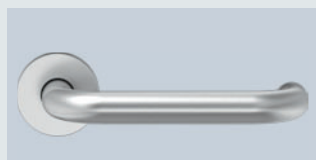

FS lever handle set D-190



FS lever handle set D-210

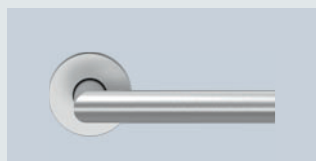

FS lever handle set D-310

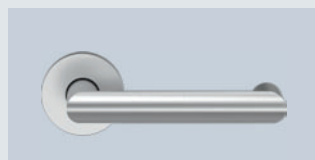

FS lever handle set D-330



FS lever handle set D-410



FS lever handle set D-490



FS lever handle set D-510



For further information and version, see the brochure "Door fittings".

Anti-panic locks / door stop

For complete door equipment

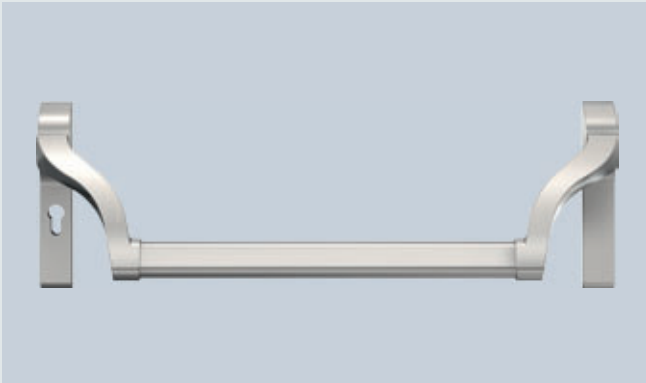

Hörmann push bar

- The largely offset lever arm for use in electronic locking cylinders and for short distances between PC
- Very stable bar handle
- Surface finish: stainless steel, coated in silver aluminium F1, coated black / red (based on EPN 900 IV Alu)
- Tested in accordance with EN 1125, EN 1634, EN 1191



Hörmann touch bar

- Can be used as a locking system acc. to EN 1125
- Surface finish: stainless steel, aluminium F1, coated
- Tested in accordance with EN 1125, EN 1634



Door stop BS 55



Door stop BS 44



Door stop BS 45



Door stop BS 65

Floor door stop BS

Stainless steel



Door stop WS 46



Door stop WS 96

Wall door stop WS

Stainless steel



Door stop WS 76



Door stop WS 82

Door sizing

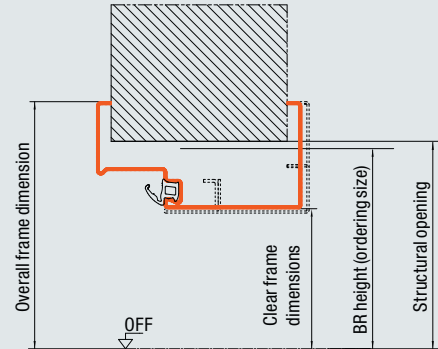
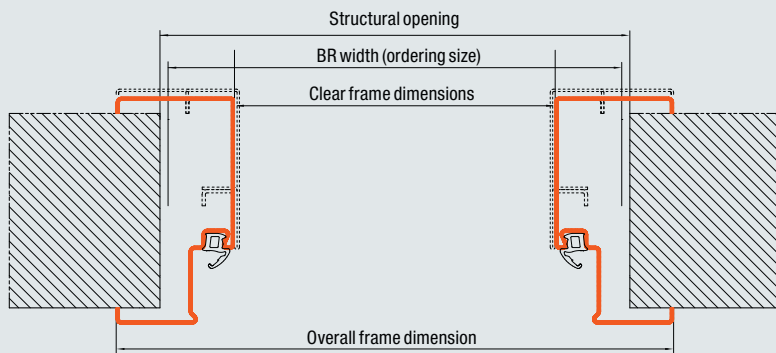

	3-sided all-round frame (doors)		4-sided all-round frame (door)	
	BR width	BR height	BR width	BR height
Doors with universal corner frame / DryFix frame / corner with counter frame / 1-part profile frame				
Clear frame dimensions	- 82	- 42	- 82	- 70
Overall frame dimension	+ 64	+ 31	+ 64	+ 76
Structural opening	+ 0 to 20	+ 0 to 15	+ 0 to 20	+ 0 to 15
Doors with 2-part profile frame				
Clear frame dimensions	- 90	- 46	- 88	- 76
Overall frame dimension	+ 64	+ 31	+ 64	+ 76
Structural opening	+ 0 to 20	+ 0 to 15	+ 0 to 20	+ 0 to 15

Doors and hatches with profile frames for partition walls: nominal size = structural opening

All dimensions in mm

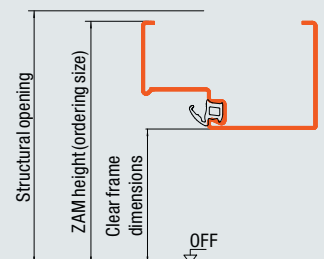
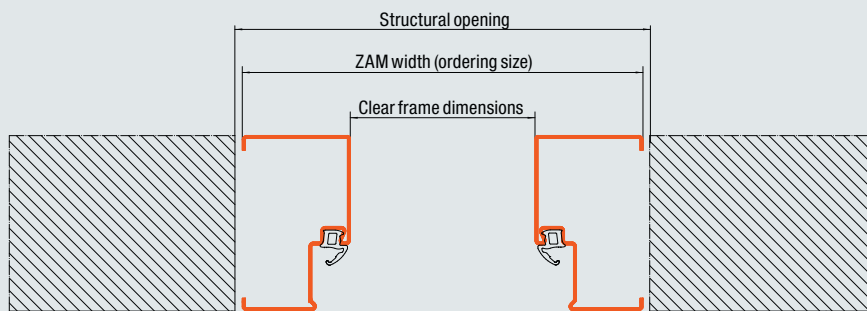

	3-sided all-round frame (doors)		4-sided all-round frame (doors)	
	ZAM width	ZAM height	ZAM width	ZAM height
Doors / hatches with block frame (fitting in the opening)				
Clear frame dimensions	- 146	- 73	- 146	- 146
Structural opening	+ 10 to 20	+ 20	+ 10 to 20	+ 20

All dimensions in mm

Clear passage widths

Clear passage widths

At an opening angle of 90°, without fittings

Single-leaf door

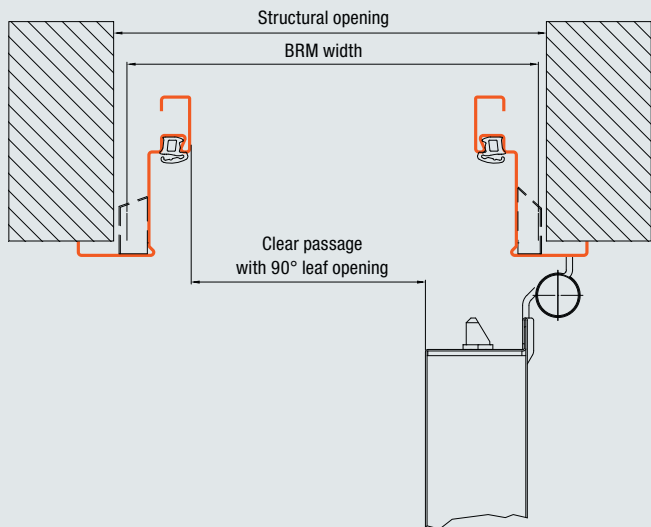

Double-leaf door

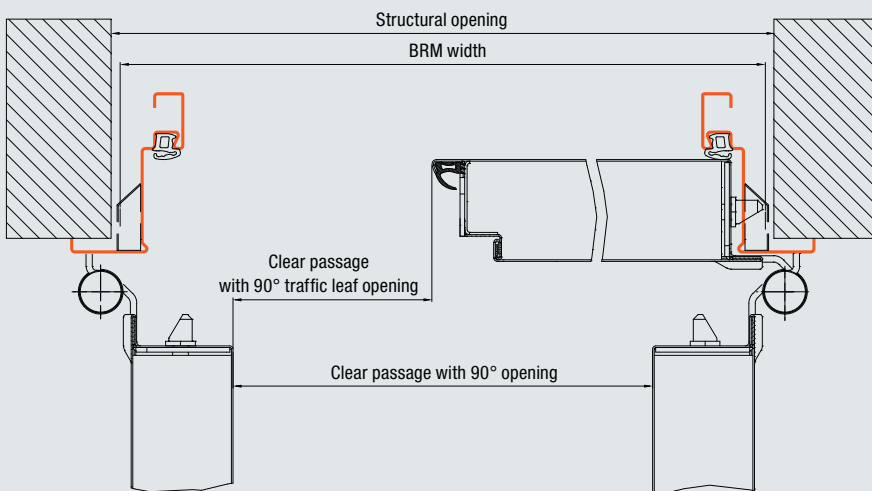

	Single-leaf door	Double-leaf door	Double-leaf door, traffic leaf
Door leaf thickness			
65 mm, thick rebate	BRB – 103	BRB – 124	BRB – 109
65 mm, thin rebate	BRB – 113	BRB – 144	BRB – 109
59 mm, flush	BRB – 126	BRB – 170	BRB – 103
75 mm, thick rebate	BRB – 105		

All dimensions in mm

Technical details

	H3 OD		H6 OD		H16 OD		
	Single-leaf	Double-leaf	Single-leaf	Double-leaf	Single-leaf	Double-leaf	
Main feature							
Standard	T30/EI ₂ 30		T60		T90/EI ₂ 90		
Standard additional function							
Thermal insulation $U_0 = W/(m^2 \cdot K)$	1,5	1,5	on request	on request	1,5	1,6	
Additional performance characteristics only with the corresponding equipment							
Smoke-tight	●	●	●	●	●	●	
Acoustic-rated (dB)	32–43	32–43	32–33	36–39	35–42	35–42	
Break-in-resistant (RC 2)	●	●	●	●	●	●	
Break-in-resistant (RC 3)	●	●			●		
Break-in-resistant (RC 4)	●*				●*		
Door leaf							
Leaf thickness	65/59	65/59	65		65	65	
Sheet thickness	1.0/1.5	1.0/1.5	1.0/1.5	1,0	1.0/1.5	1,0	
Rebate type							
Thin rebate	●	●	●	●	●	●	
Thick rebate	●	●	●	●	●	●	
Flush	●	●					
Frame variants							
Corner frame		●		●		●	
Counter frame		●		●		●	
Universal corner frame		●		●		●	
VarioFix Fire							
DryFix frame		●				●	
Profile frame (double-shell)		●		●		●	
Profile frame		●		●		●	
Block frame for fitting in the opening		●		●		●	
Approved for fitting to:							
Brickwork	●	●	●	●	●	●	
Concrete	●	●	●	●	●	●	
Gas concrete, stone slabs or concrete precision blocks	●	●	●	●	●	●	
Gas concrete slabs, reinforced, horizontal or vertical	●	●	●	●	●	●	
Prefabricated walls made of gypsum boards	●	●	●	●	●	●	
Nominal size							
Width	500	1375	500	1375	500	1375	
	–	–	–	–	–	–	
	1500	3000	1250	2500	1500	2500	
Height	500	1750	1750	1750	500	1750	
	–	–	–	–	–	–	
	2500	2500	2500	2500	2500	2500	
Door set with fixed top part							
Maximum door set height BR	3500	3500	3500	3000			
Maximum door leaf height	2500	2500	1250	2500			

All dimensions in mm

	D65 OD		D65	D65 VM	H3 G	H3 VM	H16 G		HS 75	H16 S
	Single-leaf	Double-leaf	Single-leaf	Double-leaf	Single-leaf	Double-leaf	Single-leaf	Double-leaf	Single-leaf	Single-leaf
					T30	T30	T90		db	db
	1,5	1,5	1,8	1,8	2,0	1,6	1,8		2,1	2,1
	● 32-42 ● ● ●	● 32-43 ● ●	38-45	38-45	●	●	●		● 50-61 ●	● 50-61 ●
	65/59 1.0/1.5	65 1,5	65 1,5	65 1,5	65 1,5	65 1,5	65 1,5	78 1,5	75 1,0	75 1,0
	● ● ●	●	●	●	●	● ●	●	●	●	●
	● ● ● ● ● ●	● ● ● ● ● ●	● ● ● ● ● ●	● ● ● ● ● ●	● ● ● ● ● ●	● ● ● ● ● ●	● ● ● ● ● ●	● ● ● ● ● ●	● ● ● ● ● ●	● ● ● ● ● ●
	● ● ● ● ●	● ● ● ● ●	● ● ● ● ●	● ● ● ● ●	● ● ● ● ●	● ● ● ● ●	● ● ● ● ●	● ● ● ●	● ●	● ●
	500 - 1500	1375 - 3000	625 - 1500	1250 - 3000	875 - 1500	1375 - 3000	875 - 1500	1500 - 3000	625 - 1250	625 - 1250
	500 - 2500	1750 - 2500	2500 - 3500	2500 - 3500	2500 - 3250	1750 - 3500	2500 - 3250	2000 - 3250	1750 - 2250	1750 - 2250
	3500 2500	3500 2500	3500 3500	3500 3500						

Hörmann Product Range

Everything from a single source for your construction project





Quick service with testing, maintenance and repairs
Our extensive service network means that we are always nearby and at your service around the clock.

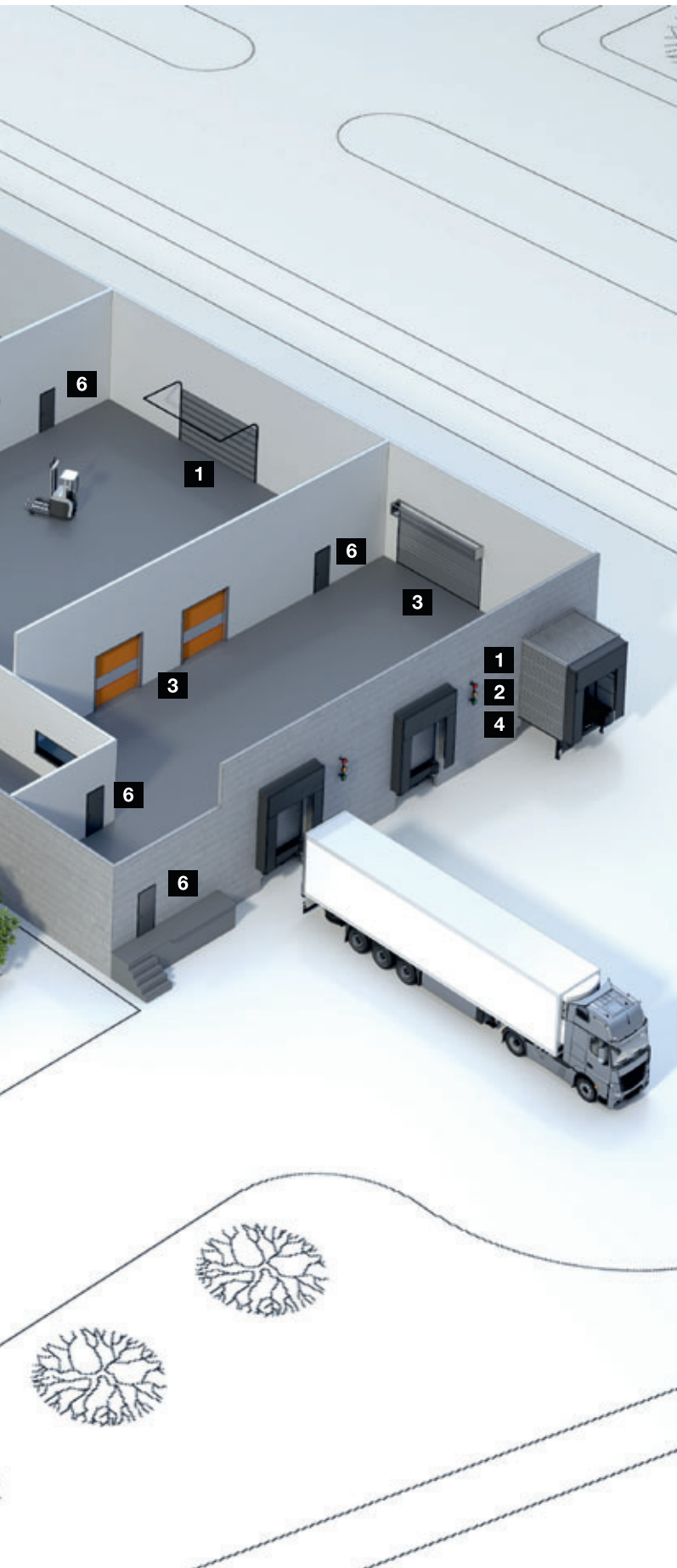

Sectional doors



Rolling shutters and rolling grilles



High-speed doors



Loading technology



Steel and stainless steel sliding doors



Steel and stainless steel construction project doors

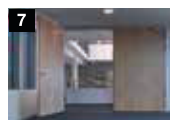

Steel frames with high-quality timber function doors from Schörghuber



Tubular frame construction project doors



Automatic sliding doors

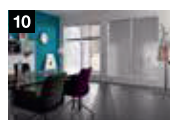

Visibility window



Collective garage doors



Bollards and road blockers



Barrier and pay station systems

Hörmann: Quality without Compromise



Hörmann KG Amshausen, Germany



Hörmann KG Antriebstechnik, Germany



Hörmann KG Brandis, Germany



Hörmann KG Brockhagen, Germany



Hörmann KG Dissen, Germany



Hörmann KG Eckelhausen, Germany



Hörmann KG Freisen, Germany



Hörmann KG Ichttershausen, Germany



Hörmann KG Werne, Germany



Hörmann Alkmaar B.V., Netherlands



Hörmann Legnica Sp. z o.o., Poland



Hörmann Beijing, China



Hörmann Tianjin, China



Hörmann LLC, Montgomery IL, USA



Hörmann Flexon LLC, Burgettstown PA, USA



Shakti Hörmann Pvt. Ltd., India

Hörmann is the only manufacturer worldwide that offers you a complete range of all major building products from one source. We manufacture in highly-specialised factories using the latest production technologies. The close-meshed network of sales and service companies throughout Europe, and activities in the USA and Asia, make Hörmann your strong partner for first-class building products, offering “Quality without Compromise”.

GARAGE DOORS
OPERATORS
INDUSTRIAL DOORS
LOADING EQUIPMENT
HINGED DOORS
DOOR FRAMES

HÖRMANN