

# Series 40 Industrial Sectional Doors

Spare Parts Overview  
Valid from 01.03.2017

**HÖRMANN**

# Hörmann Subsidiaries and Affiliates



**Hörmann KG  
Verkaufsgesellschaft**  
Upheider Weg 94-98  
D-33803 Steinhagen  
Telefon +49 5204 915-0  
Telefax +49 5204 915-277  
Internet www.hoermann.com

**Hörmann international sales organizations**

**International sales partners**

## Hörmann international sales organizations

**Hörmann Austria**  
A-5310 Mondsee  
info@hoermann.at

**Hörmann Danmark**  
DK-8920 Randers  
info@hoermann.dk

**Hörmann Hrvatska**  
HR-10000 Zagreb  
info@hoermann.hr

**Hörmann Malaysia**  
MAL-40150 Shah Alam,  
Selangor  
sales@hoermann.com.my

**Hörmann Portugal**  
P-2710-297 Sintra  
info@hoermann.pt

**Hörmann Türkiye**  
TR-Istanbul 34788  
Tasdelen-Ümraniye  
info.ist@hoermann.com.tr

**Hörmann Baltic**  
LT-14247 Vilnius r.  
info@hoermann.lt

**Hörmann Eesti**  
EST-76505 Saue  
in:info.tll@hoermann.ee

**Hörmann Hungária**  
H-2310 Szigetszentmiklós  
info@hoermann.hu

**Hörmann Maroc**  
MA-28810 Mohammedia  
info@hoermann.ma

**Hörmann Romania**  
RO-077040, Chiajna,  
Județul Ilfov  
info@hoermann.ro

**Hörmann UK**  
GB-Leicestershire  
LE67 4JW  
info@hoermann.co.uk

**Hörmann Belarus**  
BY-220125 Minsk  
s.kobrynets.min@hoermann.by

**Hörmann España**  
E-08228 Terrassa  
info.cat@hoermann.es

**Hörmann India**  
IND-Andhra Pradesh-500 015  
info@shaktihoermann.com

**Hörmann Mexico**  
MEX-66350  
Santa Catarina  
info@hoermann.com.mx

**Hörmann Russia**  
RUS-196626  
Sankt Petersburg  
info@hoermann.ru

**Hörmann Ukraine**  
UA-08300 Boryspil,  
Kyivska Obl.  
info@hoermann.com.ua

**Hörmann Belgium**  
B-3700 Tongeren  
info@hoermann.be

**Hörmann Finland**  
FIN-02420 Jorvas  
info@mesvac.fi

**Hörmann Italia**  
I-38015 Lavis (Trento)  
info@hoermann.it

**Hörmann Middle East  
& Africa**  
UAE-Dubai  
info.dxb@hoermann.com

**Hörmann Schweiz**  
CH-4702 Oensingen  
info@hoermann.ch

**Hörmann Vietnam**  
VN-Bac Ninh Province  
info.han@hoermann.vn

**Hörmann Brasil**  
BR-05305 002 São Paulo SP  
info.sao@hoermann.com.br

**Hörmann Flexon**  
USA-Burgettstown,  
PA 15021  
info@hoermann-flexon.com

**Hörmann Japan**  
JP-103-0 002 Tokyo  
t.takasu.tok@hoermann.jp

**Hörmann Nederland**  
NL-3771 MB Barneveld  
info@hoermann.nl

**Hörmann Serbia**  
SRB-11271 Beograd-Surčin  
info@hoermann.rs

**Hörmann Bulgaria**  
BG-1532 Sofia  
info.sof@hoermann.bg

**Hörmann France**  
F-89107 Sens  
info@hoermann.fr

**Hörmann Kazakhstan**  
KZ-050004 Almaty  
info@hoermann.kz

**Hörmann Norge**  
N-4640 Søgne  
info@hoermann.no

**Hörmann Slovenská  
republika**  
SK-903 01 Senec  
info.bts@hoermann.com

**Hörmann Česká republika**  
CZ-252 68 Středokluky  
info@hoermann.cz

**Hörmann Hellas**  
GR-19400 Koropi  
info@hoermann.gr

**Hörmann Korea**  
KR-Kyunggi-do 463-400  
info@hoermann.co.kr

**Hörmann Polska**  
PL-62-052 Komorniki  
info@hoermann.pl

**Hörmann Svenska**  
S-70369 Örebro  
info@hoermann.se

**Hörmann China**  
CN-100176 Beijing  
info@hoermann.cn

**Hörmann Hong Kong**  
HK-25 Westlands Road,  
Quarry Bay  
info@hoermann.com.hk

**Hörmann LLC**  
USA-60538 Montgomery,  
Illinois  
info@hoermann.us

You can find more details on our foreign subsidiaries and respective regional sales offices at [www.hoermann.com](http://www.hoermann.com)

## International sales partners

Ägypten  
Albanien  
Algerien  
Argentinien  
Armenien  
Aserbaidschan

Australien  
Bangladesch  
Bosnien-Herzegowina  
Chile  
Finnland  
Georgien

Indonesien  
Irland  
Island  
Israel  
Kolumbien  
Kosovo

Luxemburg  
Malta  
Mazedonien  
Moldawien  
Mongolei  
Montenegro

Neuseeland  
Peru  
Philippinen  
Slowenien  
Taiwan  
Thailand



Tunesien  
Turkmenistan  
Uruguay  
Usbekistan  
Venezuela

Prices in €. Copyright. No part of this price list may be reproduced without our permission. All details subject to change.

# Contents

Designation	Page
■ Overview of Manufactured Door Models	4
■ STE 40 Overview	6
■ TPU 40 Overview	7
■ SPU 40 Overview	8
■ APU 40 N / TAP 40 / APU 40 B Overview	9
■ ALR 40 N / TAR 40 / ALR 40 B Overview	10
■ ALS 40 Overview	11
■ ASP 40, ASR 40 Overview	12
■ DPU Overview	13
■ Overview of Track Applications	14
■ Overview of DPU Track Applications	15
■ Overview of Track Applications – Interior View	16
■ Identifying the Torsion Springs	19
■ Glazing Position for Door Section Heights 500, 625 and 750 mm	20
■ Data Label Overview	21
■ 1. Double-Skinned Door Sections 42 mm	23
■ 2. Double-Skinned Door Sections 80 mm	57
■ 3. Door Sections Made of Aluminium Profiles	58
■ 4. Accessories for Door Sections	72
■ 5. Fitting Parts for Door Sections	87
■ 6. Frames	102
■ 7. Torsion Spring Shafts	110
■ 8. Fitting Parts for Doors	123
■ 9. General Accessories	135
■ Spare parts order form	150
■ General Terms and Conditions of Sale and Delivery (Issue 01.03.2016)	151



## Symbols used

Symbol	Description
	Price on request
	Please note the extended delivery times.
	Article has been replaced.

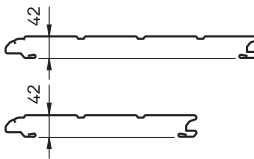
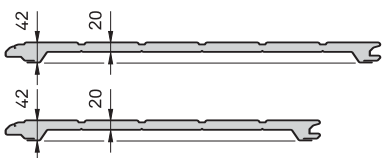
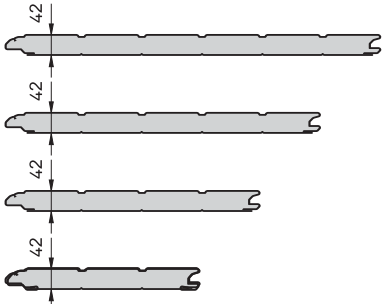
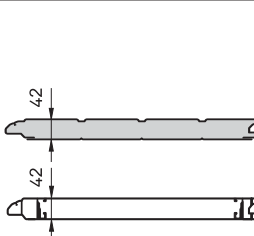
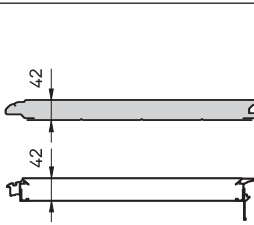
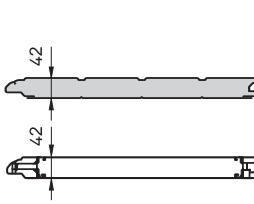
# Overview of Manufactured Door Models

Door type	Symbols	Identifying features	Production period
<b>HÖRMANN sectional door STE 40</b>			
<b>STE 40</b>		Single-skinned, Stucco-textured, plastic primer coated  <b>Door sections no longer available, use SPU 40 door sections instead</b>	09.07.01 – 29.02.2008
<b>HÖRMANN sectional door TPU 40</b>			
<b>TPU 40</b>		Double-skinned 42 / 20 mm, PU-foamed, Stucco-textured, plastic primer coated  <b>Door sections no longer available, use SPU 40 door sections instead</b>	09.07.01 – 23.02.2006
<b>HÖRMANN sectional door SPU 40</b>			
<b>SPU 40</b>		Double-skinned 42 mm, PU-foamed, Stucco-textured, plastic primer coated  Double-skinned 42 mm, PU-foamed, Micrograin, plastic primer coated	09.07.01 – 28.02.2013  01.02.09 – 28.02.2013
<b>HÖRMANN sectional door APU 40, ASP 40, TAP 40</b>			
<b>APU 40</b>		Bottom section 500, 750, 1000 or 1500 mm Double-skinned, PU-foamed, Stucco-textured, plastic primer coated  Bottom section 500, 750, 1000 or 1500 mm Double-skinned, PU-foamed, Micrograin, plastic primer coated  Other door sections made of standard (NF) anodised aluminium extrusions E6 / EV1	09.07.01 – 28.02.2013  01.02.09 – 28.02.2013
<b>ASP 40</b>		Bottom section 500, 750, 1000 or 1500 mm Double-skinned, PU-foamed, Micrograin, plastic primer coated  Bottom section 500, 750, 1000 or 1500 mm Double-skinned, PU-foamed, Stucco-textured, plastic primer coated  Other door sections made of anodised FP profiles E6 / EV1	01.07.09 – 28.02.2013  01.08.10 – 28.02.2013
<b>TAP 40</b>		Bottom section 500, 750, 1000 or 1500 mm Double-skinned, PU-foamed, Stucco-textured, plastic primer coated  Bottom section 500, 750, 1000 or 1500 mm Double-skinned, PU-foamed, Micrograin, plastic primer coated  Other door sections made of anodised aluminium extrusions E6 / EV1 in a version with thermal breaks (WF)	09.07.01 – 28.02.2013  01.02.09 – 28.02.2013

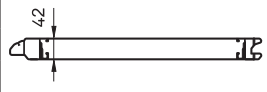
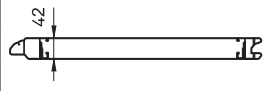
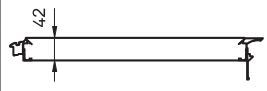
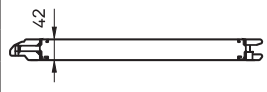
# Overview of Manufactured Door Models

Door type	Symbols	Identifying features	Production period
<b>HÖRMANN sectional door ALR 40, ALS 40, ASR 40, TAR 40</b>			
<b>ALR 40</b>		Anodised aluminium extrusions E6 / EV1 In standard version	09.07.01 – 28.02.2013
<b>ALS 40</b>		Anodised aluminium extrusions E6 / EV1 In standard version	01.03.04 – 28.02.2013
<b>ASR 40</b>		Anodised FP profiles E6 / EV1	01.07.09 – 28.02.2013
<b>TAR 40</b>		Anodised aluminium extrusions E6 / EV1 In a version with thermal breaks	09.07.01 – 28.02.2013
<b>HÖRMANN sectional door DPU</b>			
<b>DPU</b>		Double-skinned 80 mm, PU-foamed, Stucco-textured, plastic primer coated	01.10.05 – 28.02.2013

# STE 40 Overview

Viewed from inside

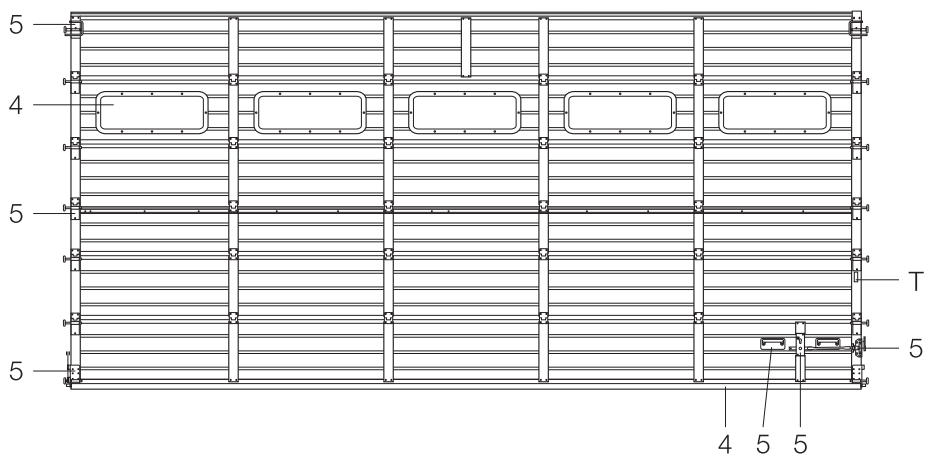
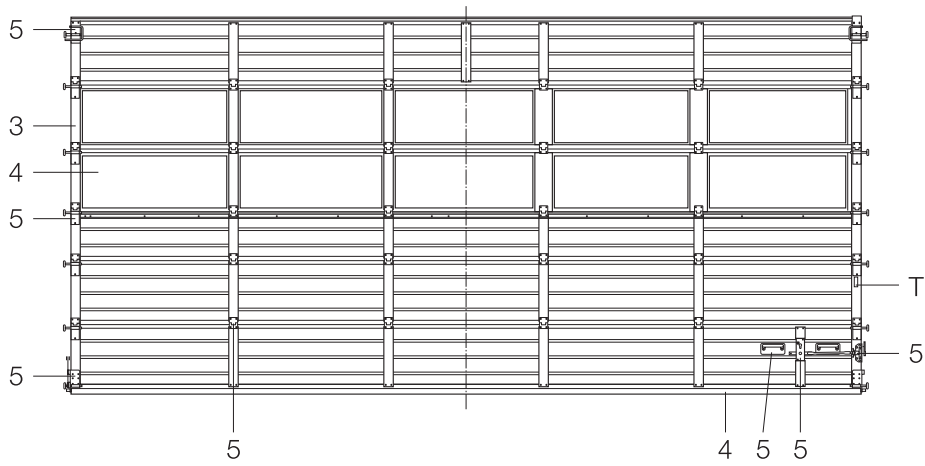
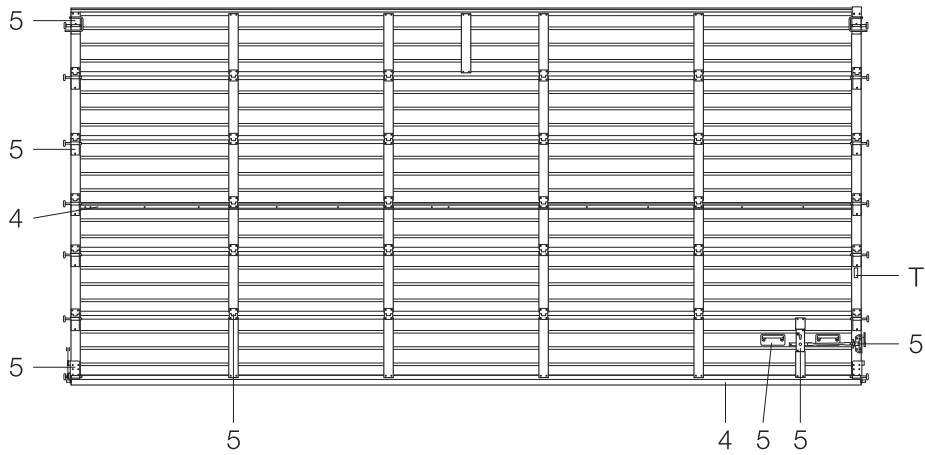

- 3 Aluminium extrusion door sections
- 4 Accessories for door sections
- 5 Fitting parts for door sections
- T Data label

# TPU 40 Overview

Viewed from inside

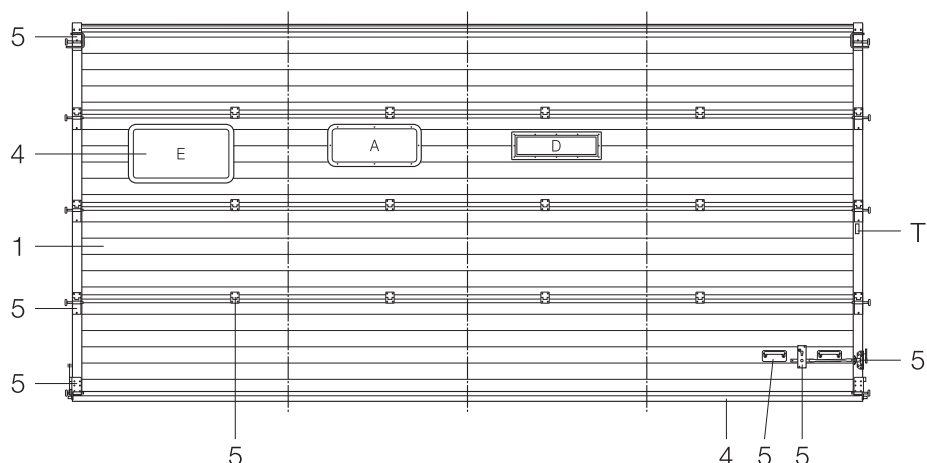
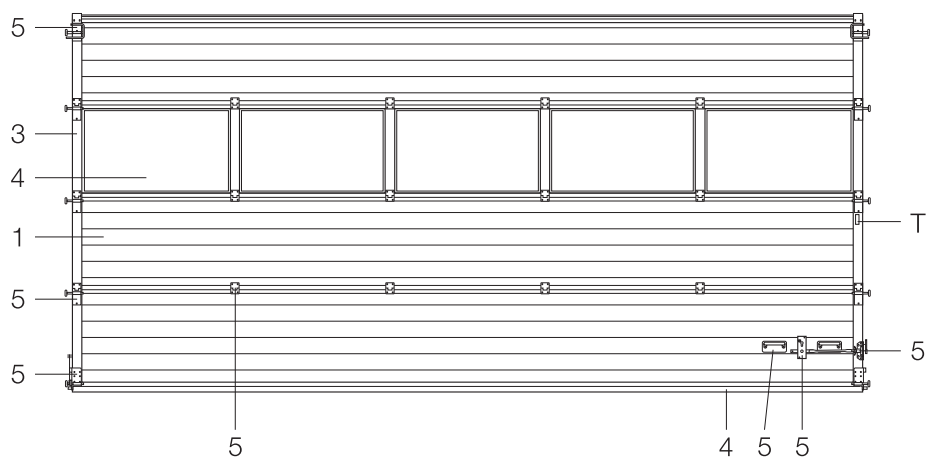
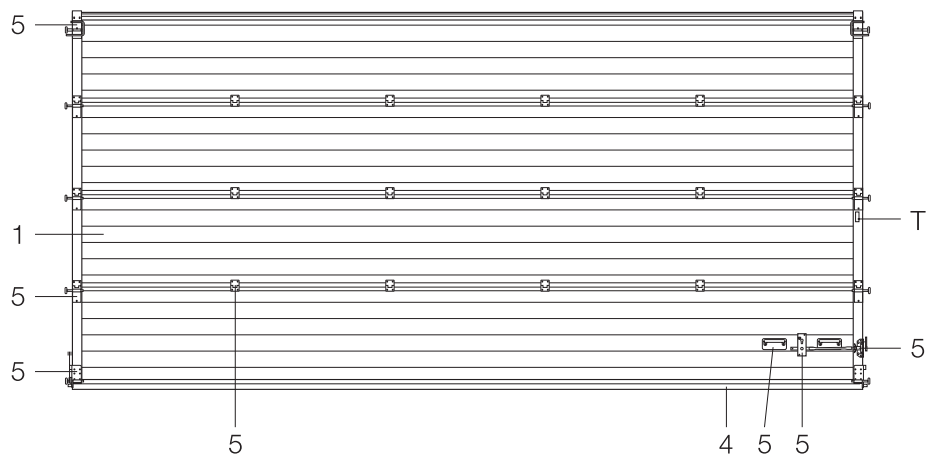

- 1 Double-skinned door sections 42/20 mm  
(no longer available - use 42 mm door sections instead)
- 3 Aluminium extrusion door sections
- 4 Accessories for door sections
- 5 Fitting parts for door sections
- T Data label

# SPU 40 Overview

Viewed from inside

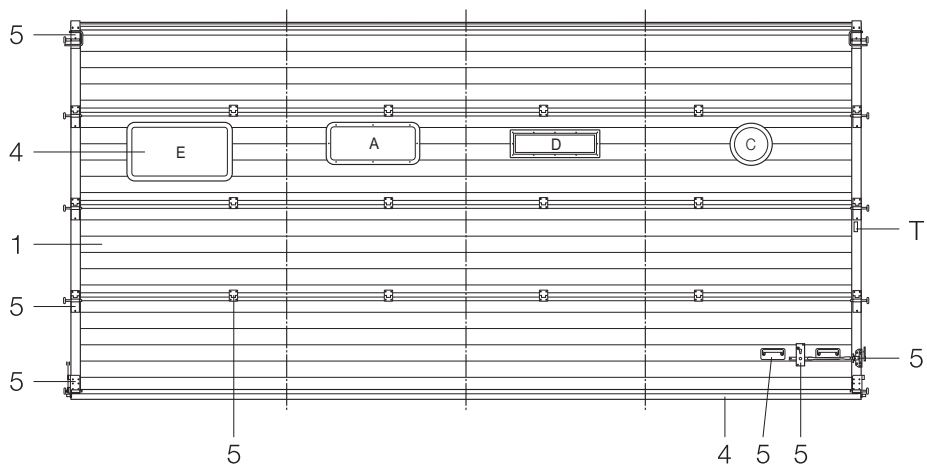
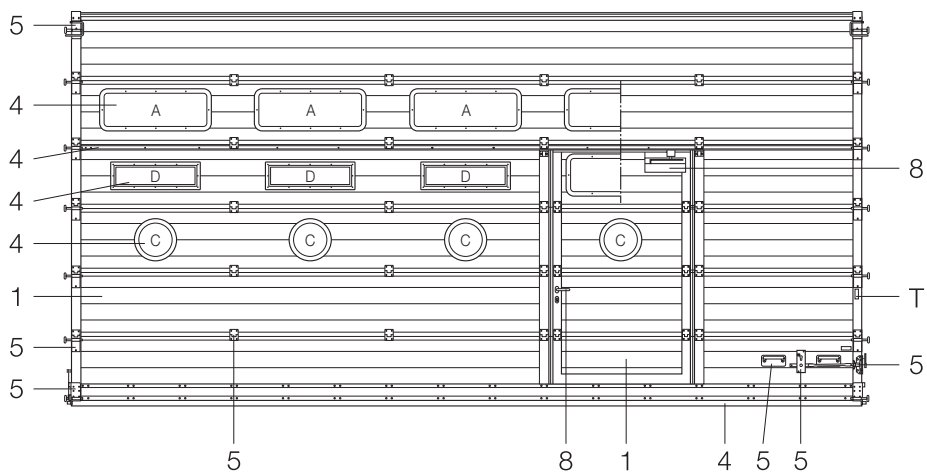
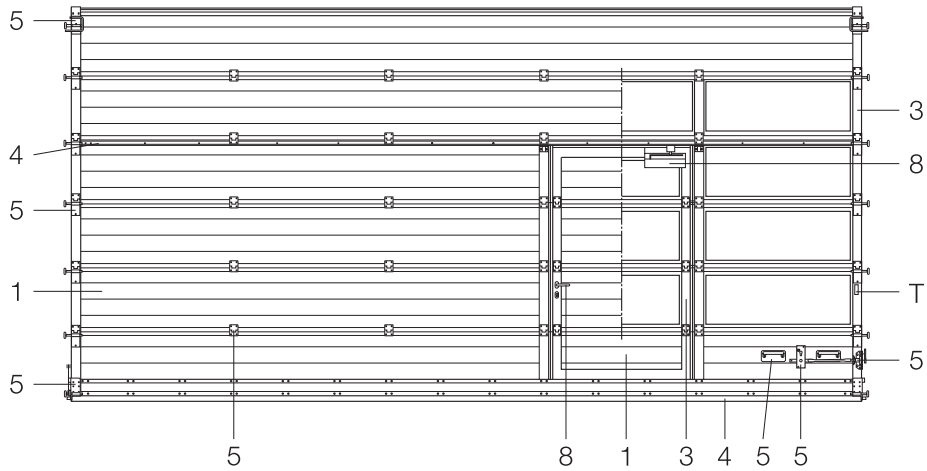

- 1 Double-skinned door sections 42 mm
- 3 Aluminium extrusion door sections
- 4 Accessories for door sections
- 5 Fitting parts for door sections
- 8 Fitting parts for doors
- T Data label



# APU 40 N / TAP 40 / APU 40 B Overview

Viewed from inside

**APU 40 N  
TAP 40**

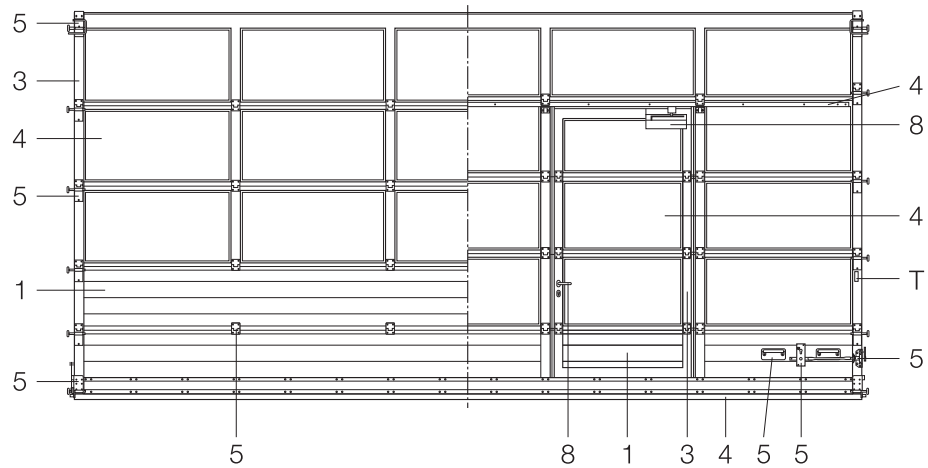
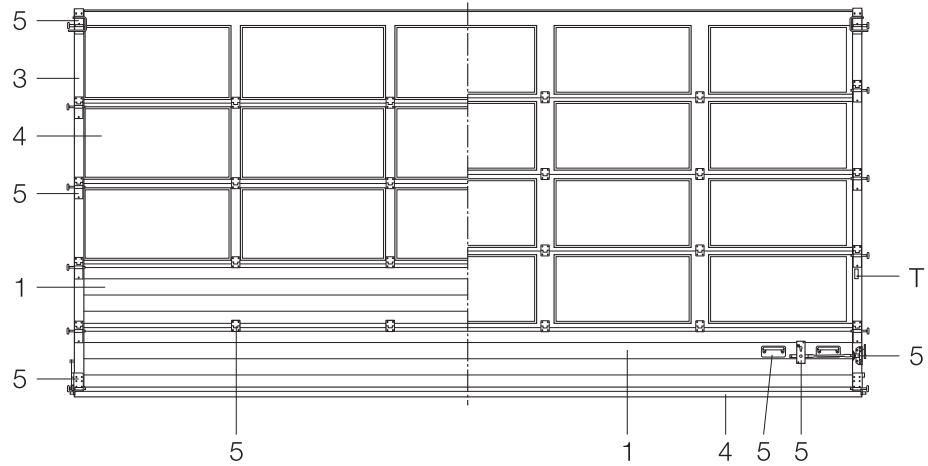

**APU 40 B**

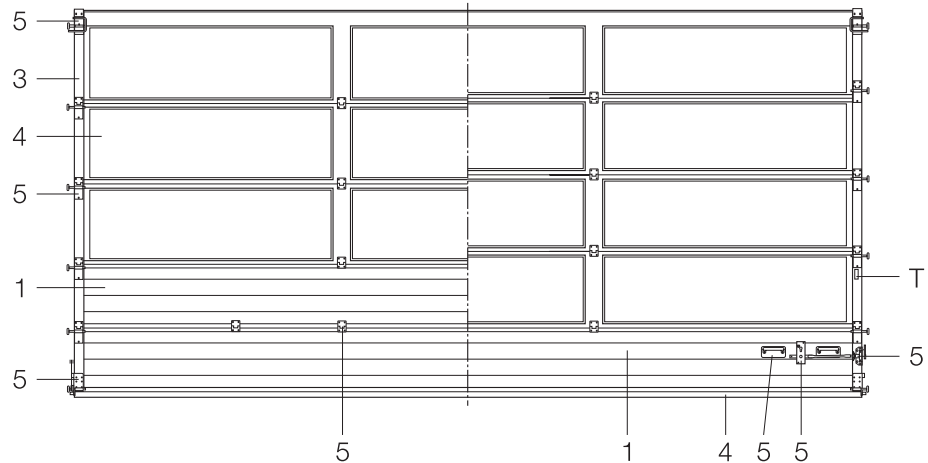

- 2 Double-skinned door sections
- 3 Aluminium extrusion door sections
- 4 Accessories for door sections
- 5 Fitting parts for door sections
- 8 Fitting parts for doors
- T Data label

# ALR 40 N / TAR 40 / ALR 40 B Overview

Viewed from inside

ALR 40 N  
TAR 40

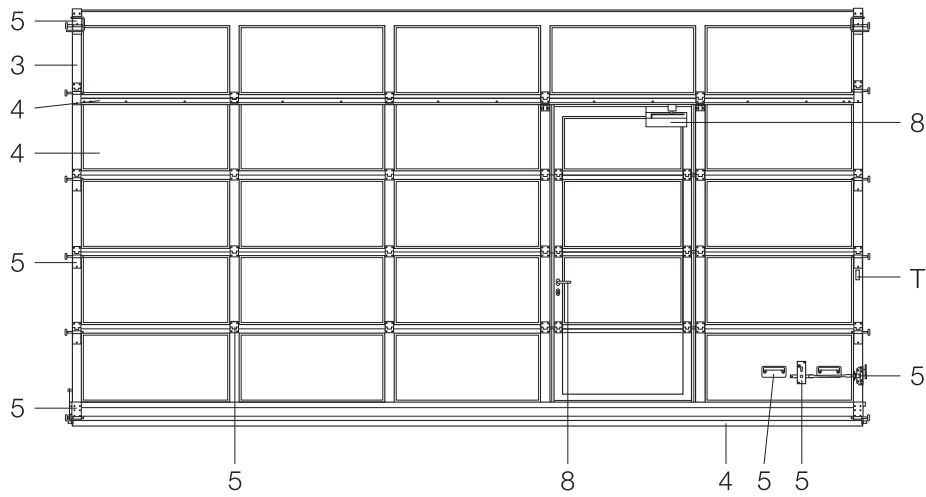
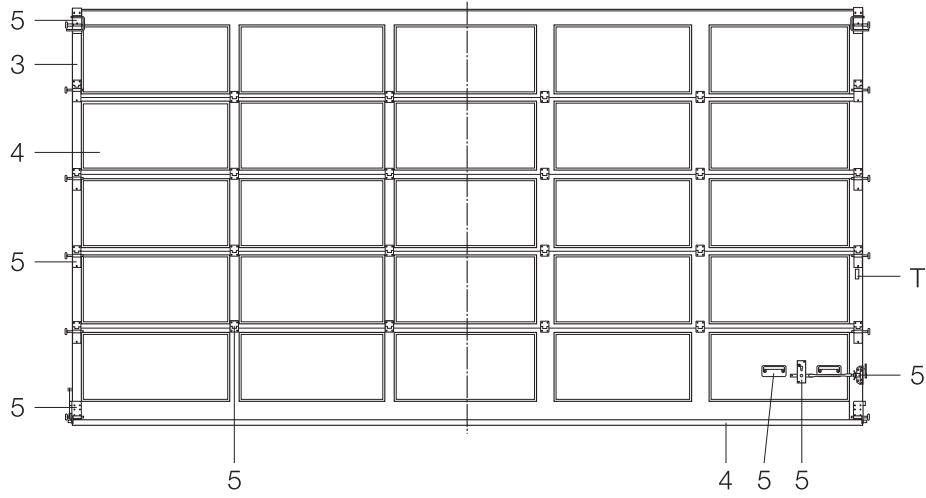

ALR 40 B

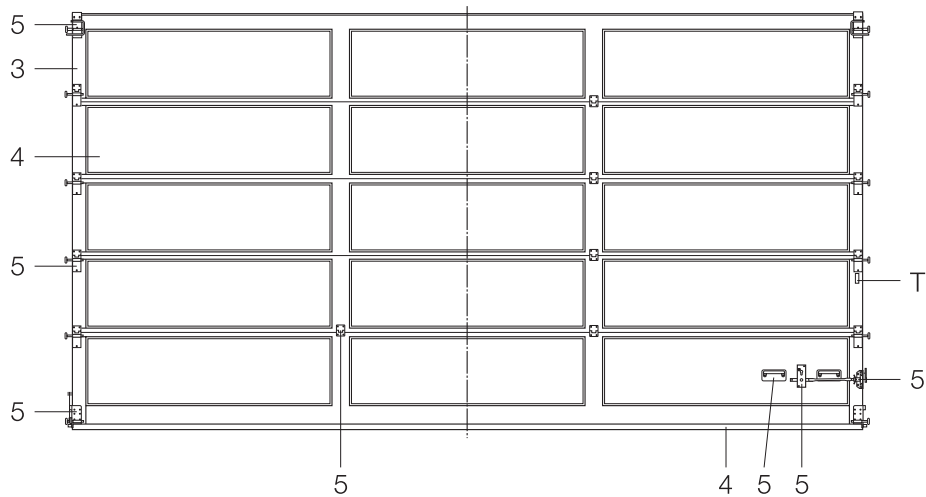

- 3** Aluminium extrusion door sections
- 4** Accessories for door sections
- 5** Fitting parts for door sections
- 8** Fitting parts for doors
- T** Data label

# ALS 40 Overview

Viewed from inside

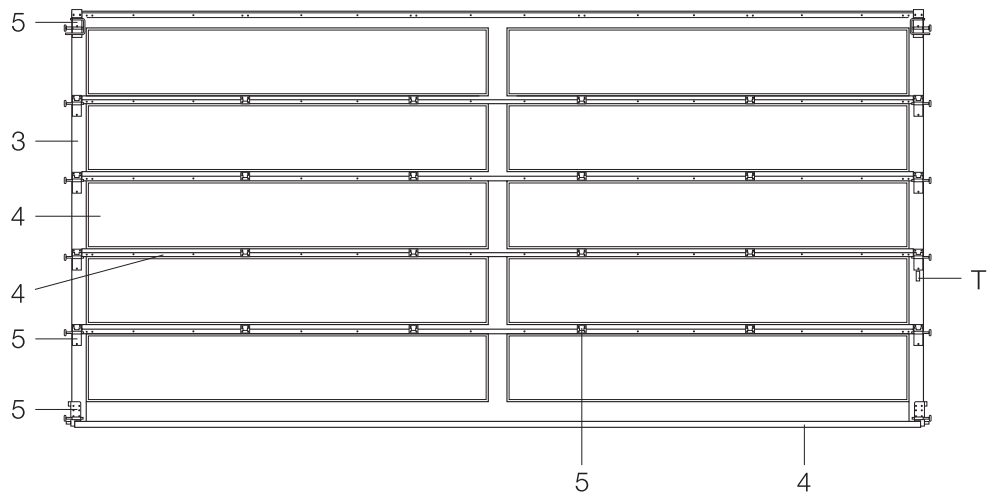
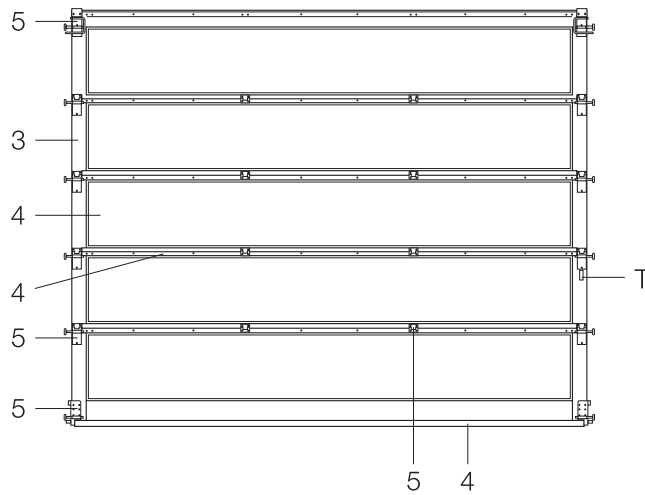

- 3 Aluminium extrusion door sections
- 4 Accessories for door sections
- 5 Fitting parts for door sections
- T Data label

# ASP 40, ASR 40 Overview

Viewed from inside

## ASP 40

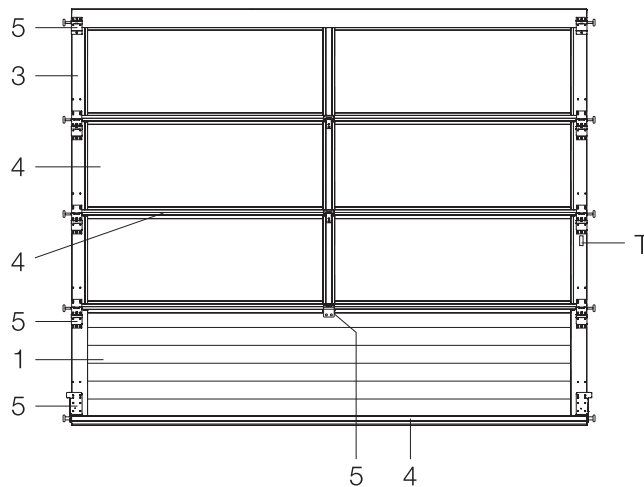

## ASR 40

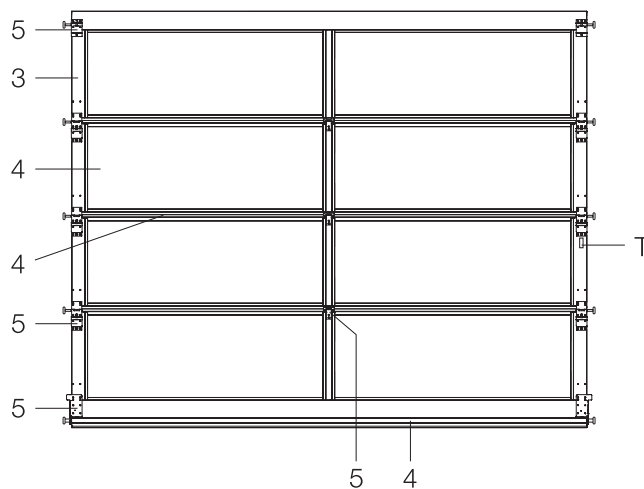

- 2 Double-skinned door sections
- 3 Aluminium extrusion door sections
- 4 Accessories for door sections
- 5 Fitting parts for door sections
- T Data label

# DPU Overview

Viewed from inside

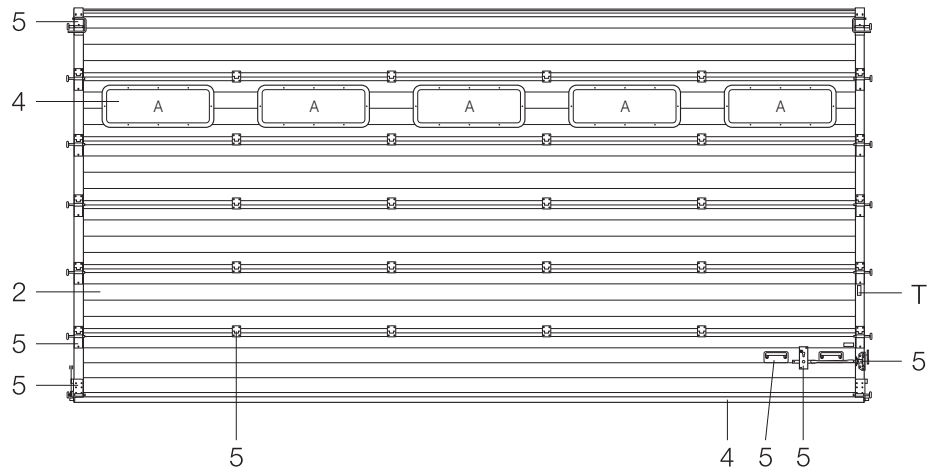

- 2 Double-skinned door sections 80 mm
- 4 Accessories for door sections
- 5 Fitting parts for door sections
- T Data label

# Overview of Track Applications

**Note:** For individual parts, see 6. Frames

## N track applications

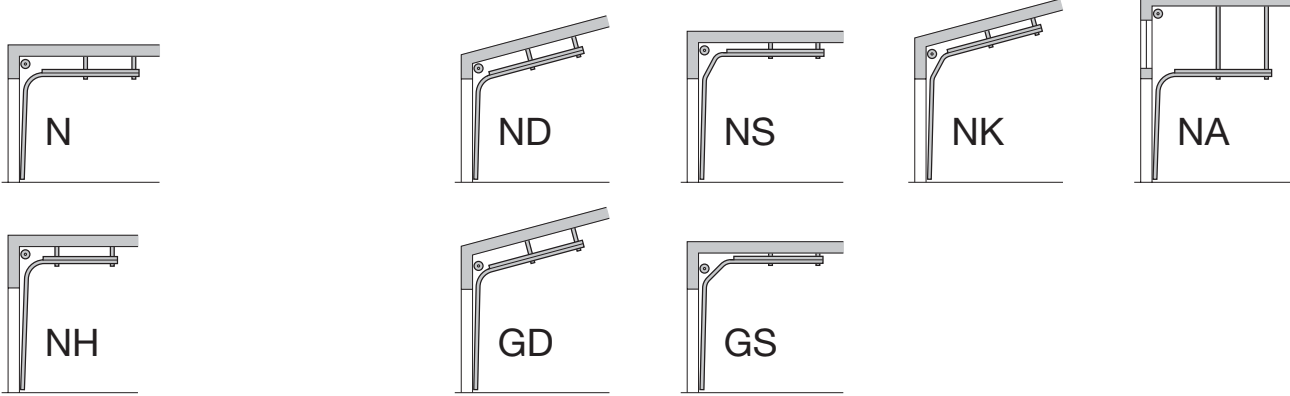

## H track applications

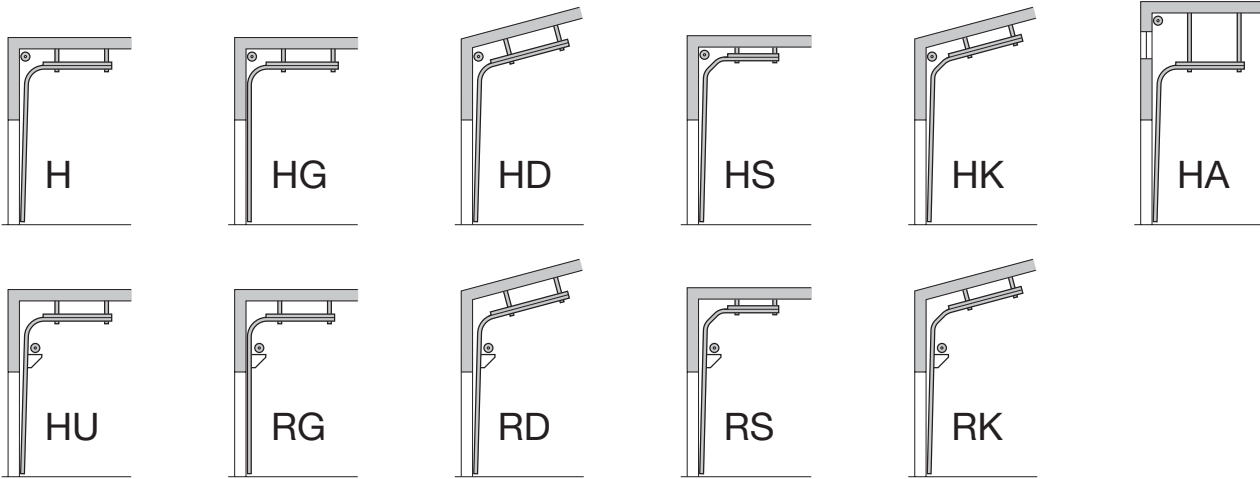

## L track applications



## V track applications

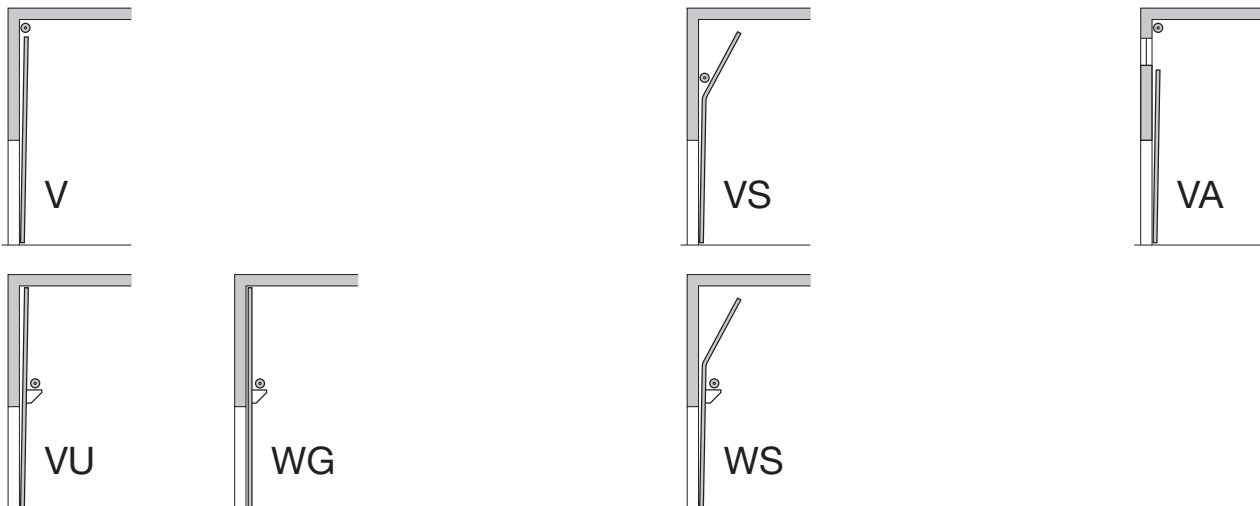

# Overview of DPU Track Applications

**Note:** For individual parts, see 6. Frames

## N track applications

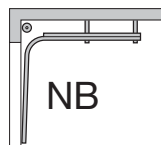

## H track applications

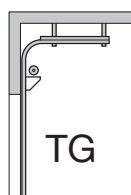
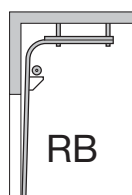
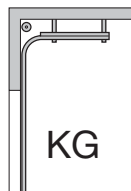
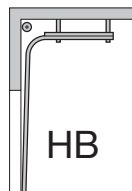

## V track applications

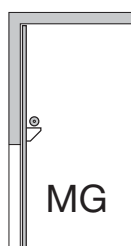
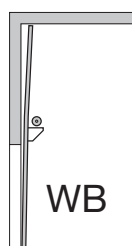
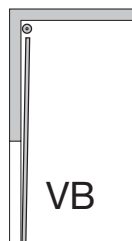

# Overview of Track Applications – Interior View

**Note:** For individual parts, see 7. Torsion Spring Shafts

## N track applications

Track sizes 1, 2 and 3 from 09.07.01

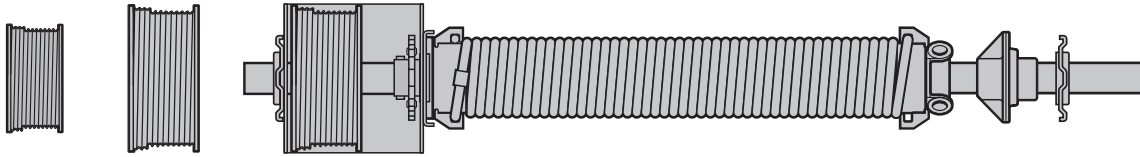

## L track applications

Track sizes 1 and 2 from 09.07.01

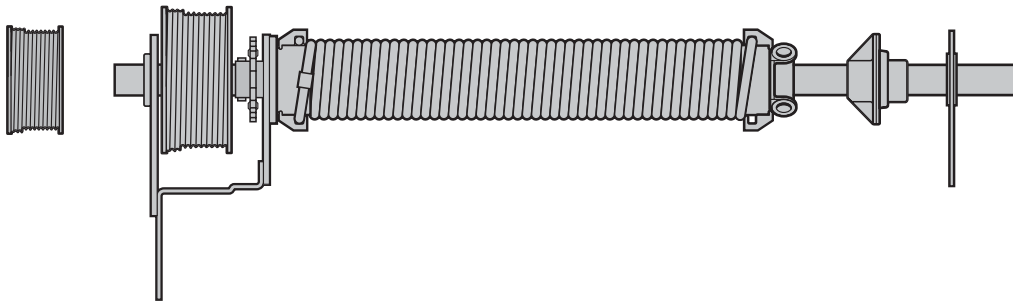

## H track applications

Track sizes 4, 5 and 8 from 09.07.01

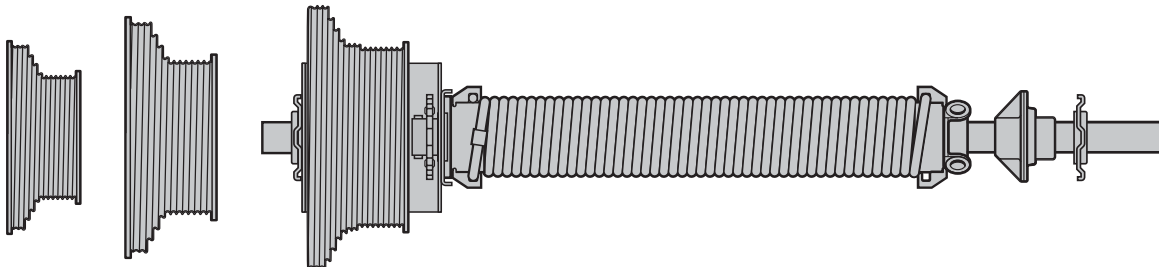



# Overview of Track Applications – Interior View

**Note:** For individual parts, see 7. Torsion Spring Shafts

## HU track applications

Track sizes 4 and 5 from 09.07.01

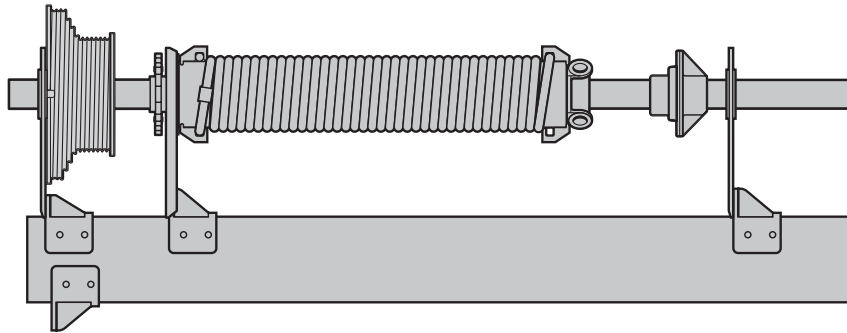

Track size 4 from 03.07.09 (in specific size ranges)

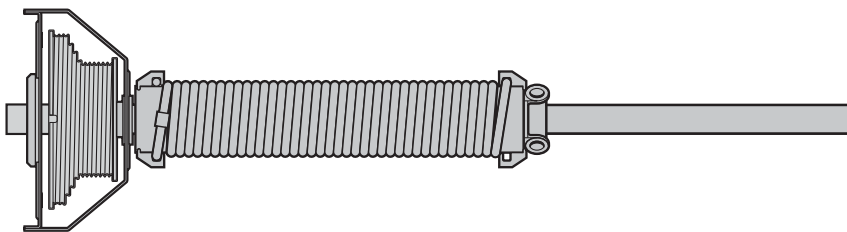

## V track applications

Track sizes 6 and 7 from 09.07.01

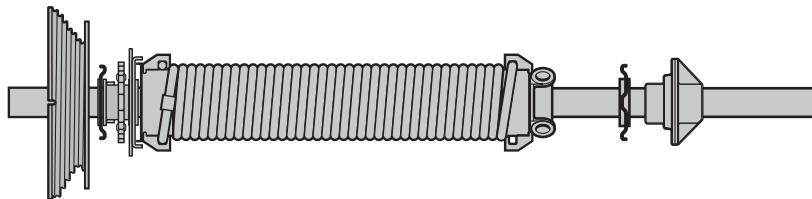

## VU track applications

Track sizes 6 and 7 from 09.07.01

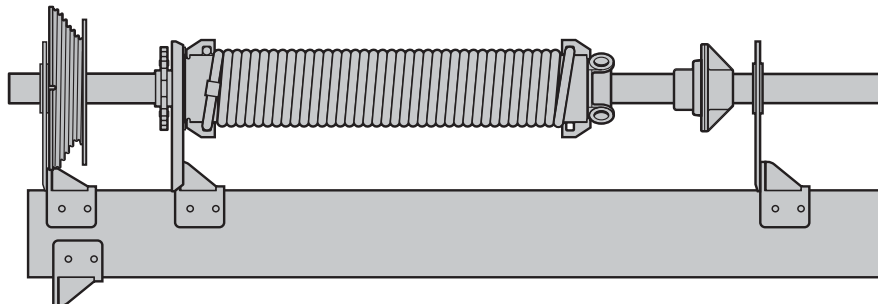

Track size 6 from 03.07.09 (in specific size ranges)

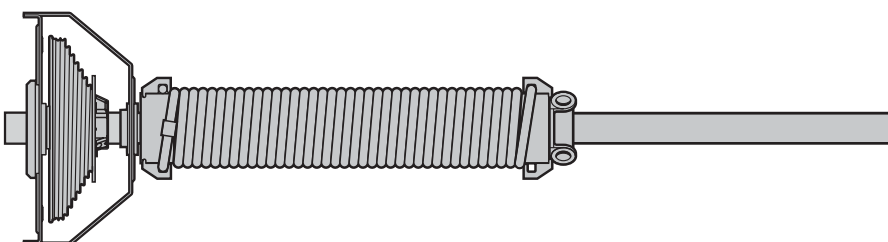

# Overview of Track Applications – Interior View

**Note:** For individual parts, see 7. Torsion Spring Shafts

## Track applications N, H, V

Double spring shaft from 09.07.01

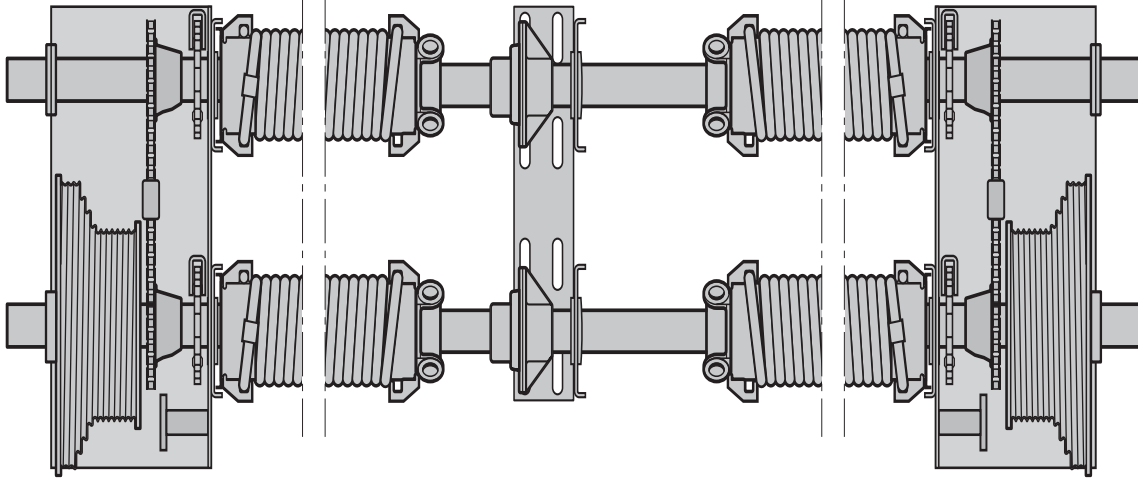

## Track applications HU, VU

Double spring shaft from 09.07.01

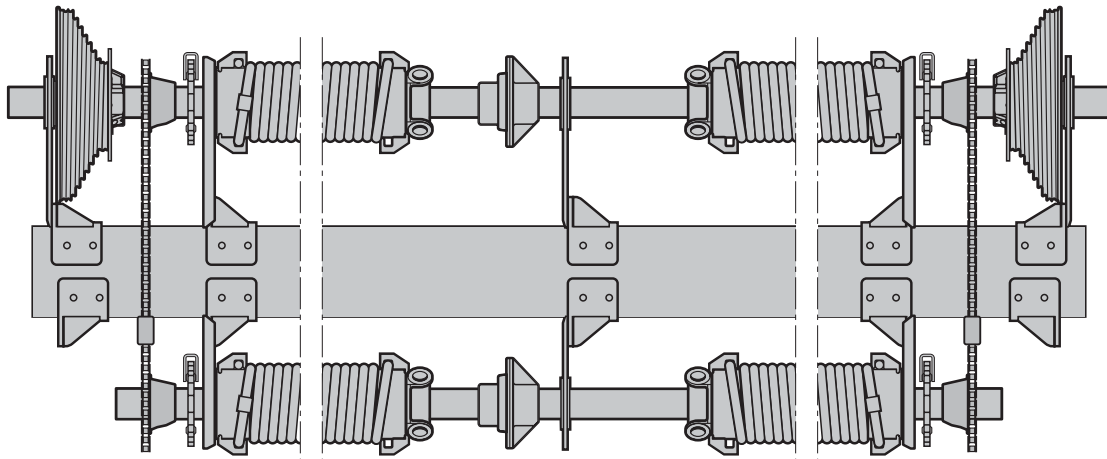

# Identifying the Torsion Springs

Viewed from inside

1)

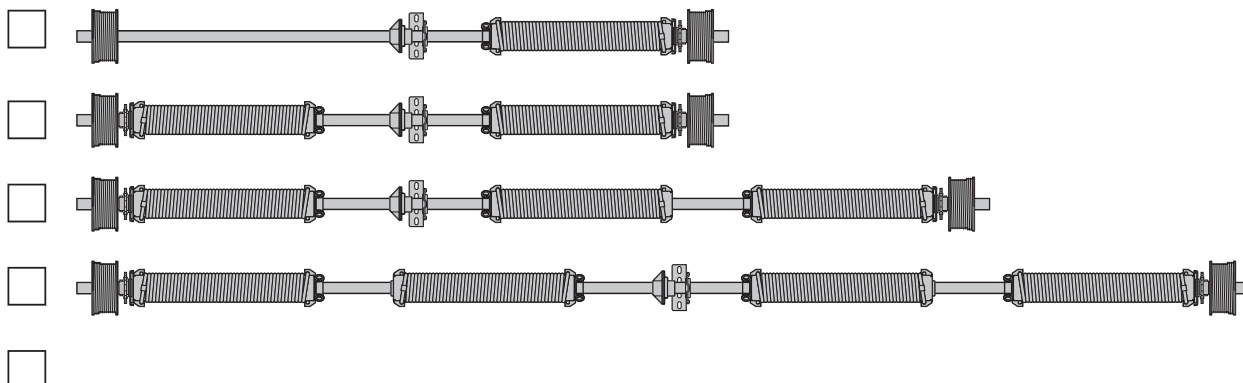

The arrangement above only applies to spring shafts with  $\varnothing 40$  mm.

2)

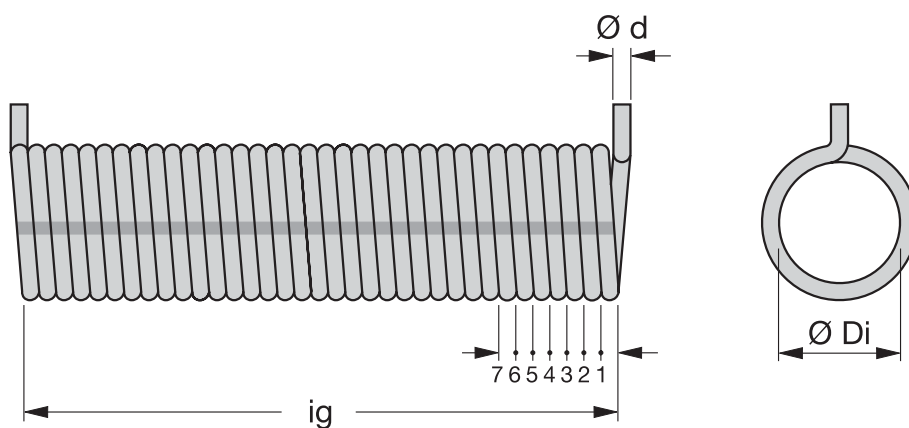

Left torsion spring

Right torsion spring

The following information is required if the order number can no longer be determined, if the door no longer has a data label or the spring identification (plastic label) is missing:

1. Mark the number and arrangement of the springs
2. Mark the left or right spring
3. Inside  $\varnothing Di$ : \_\_\_\_\_
4. Wire  $\varnothing d$ : \_\_\_\_\_  
(specify with an accuracy of 1 / 10 mm)
5. Total windings  $ig$ : \_\_\_\_\_  
(count when the spring is relaxed)

# Glazing Position for Door Section Heights 500, 625 and 750 mm

Glazing positions for compound window type A, type C, type D and type E.  
The illustrations correspond to a section depth of 42 mm.

## Door section height 750 mm (SPU 40)

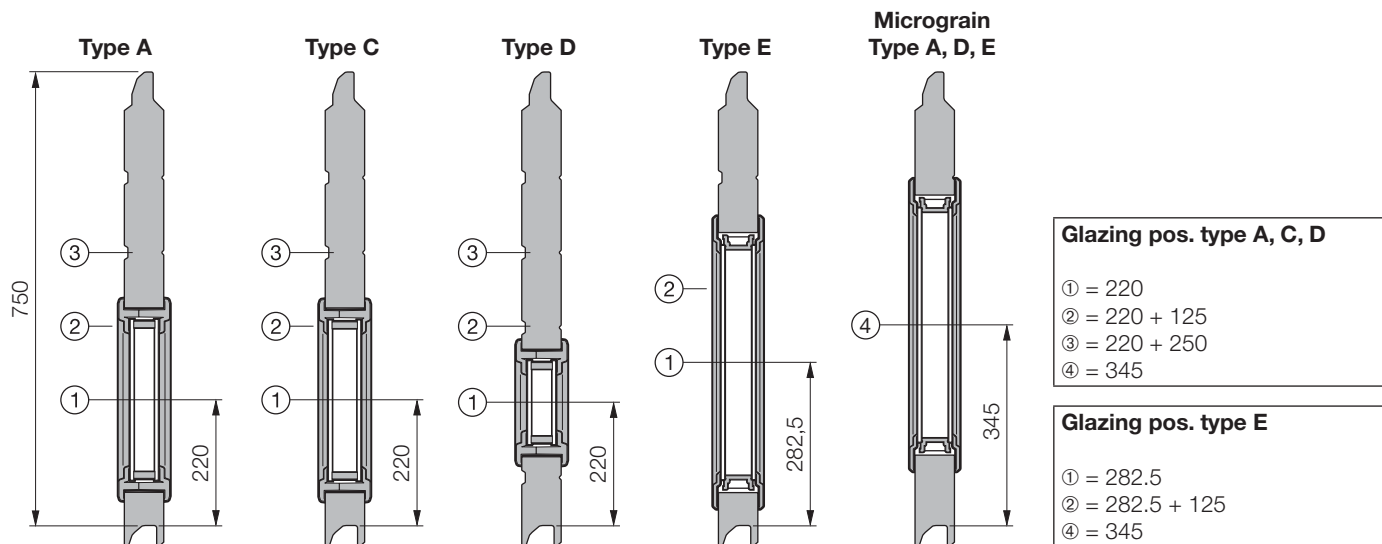

## Door section height 625 mm (SPU 40)

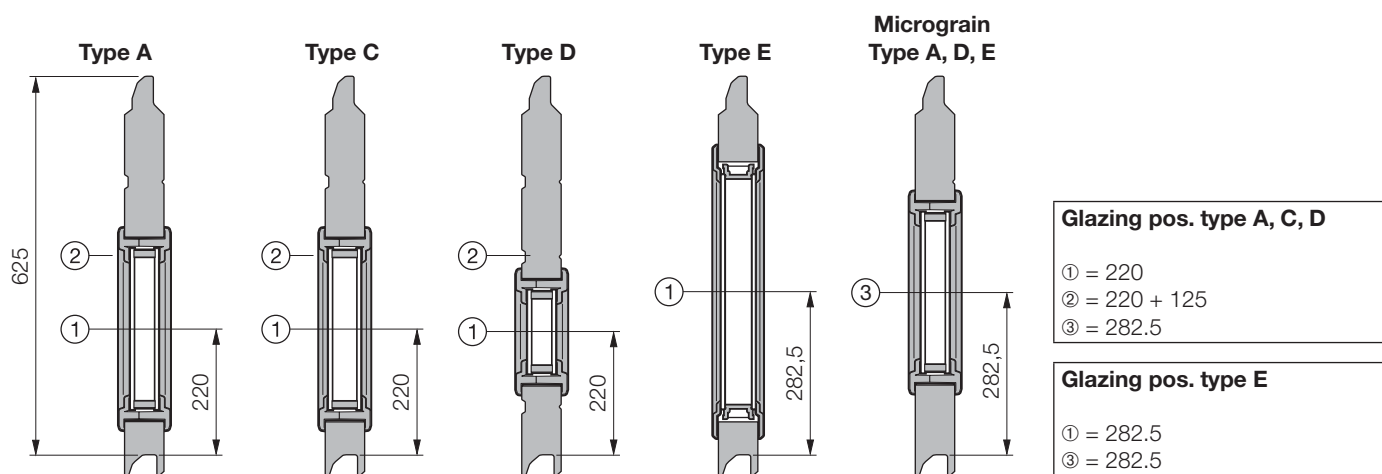

## Door section height 500 mm (STE 40 and SPU 40)

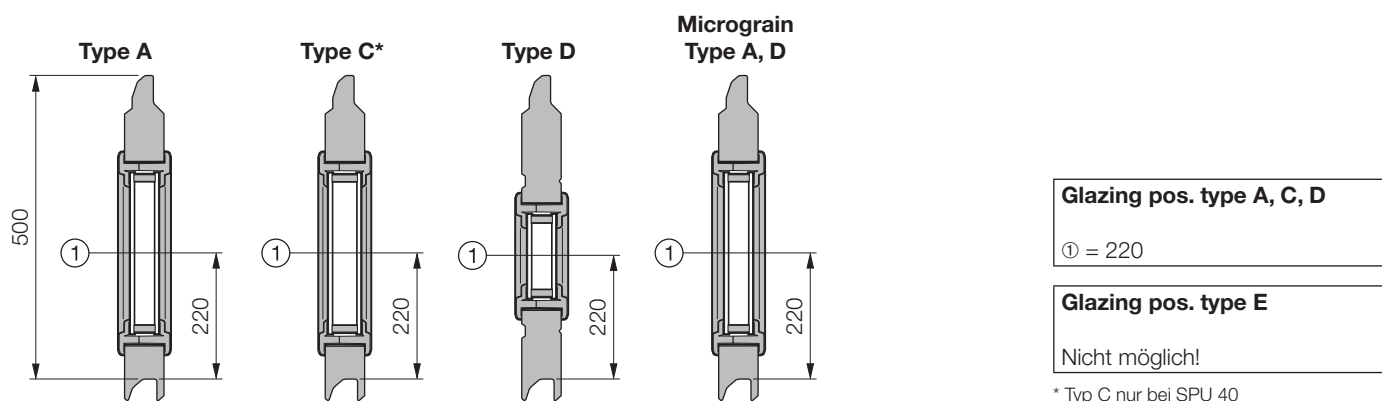

# Data Label Overview

<b>DEUTSCH</b>	<p><b>Bei Ersatzbestellung:</b> Vom Typenschild, Auftrags-Nr.: ①, Tor-Nr.: ②, Produkt-Nr.: ③, Typ: ④, Baujahr: ⑤ zusammen mit der Artikelnummer des Ersatzteiles angeben.</p>	
<b>ENGLISH</b>	<p><b>Spares ordering:</b> Please state the order no. ①, door no. ②, product no. ③, type ④, year of manufacture ⑤ together with the article no. of the spare part.</p>	
<b>FRANÇAIS</b>	<p><b>En cas de commande de pièces détachées:</b> Indiquer numéro de fabrication ①, numéro de la porte ②, numéro de produit ③, type ④, l'année de fabrication ⑤ ainsi que le numéro d'article de la pièce détachée à l'aide des données sur le label.</p>	<p><b>Auftrags-Nr:</b> <b>Order No:</b> <b>No. de fabrication:</b> ①</p>
<b>NEDERLANDS</b>	<p><b>Bij bestelling van onderdelen:</b> Ordernummer ①, deurtipe ②, produktnummer ③, type ④, bouwjaar ⑤ en artikelnummer van het vervangstuk aanduiden aan de hand van de gegevens op het label.</p>	<p><b>Tor-Nr:</b> <b>Door No:</b> <b>No. de la porte :</b> ②</p>
<b>ESPAÑOL</b>	<p><b>Pedido de piezas de recambio:</b> Para cualquier pieza de recambio indicar de la placa de características el número de comisión ①, referencia de puerta ②, referencia de producto ③, modelo de puerta ④, el año de fabricación ⑤ con los números de piezas de recambio.</p>	<p><b>Produkt-Nr:</b> <b>Product No:</b> <b>No. de produit:</b> ③</p>
<b>ITALIANO</b>	<p><b>Nel caso di ordinazione ricambi:</b> Rilevare dall'etichetta il n° di commessa ①, il n° di portone ②, il n° di prodotto ③, il tipo di portone ④, l'anno di produzione ⑤ e fornire il tutto unitamente al n° di articolo dei ricambi desiderati.</p>	<p><b>Typ:</b> <b>Type:</b> <b>Type:</b> ④</p>
<b>PORTUGUÊS</b>	<p><b>Nota de Encomenda Suplementar:</b> Por favor, indique o n° da nota de encomenda ①, n° da porta ②, n.º do produto ③, tipo ④, ano de fabrico ⑤, juntamente com o n° de artigo das peças opcionais.</p>	<p><b>Breite [mm]:</b> <b>Width [mm]:</b> <b>Largeur [mm]:</b></p>
<b>POLSKI</b>	<p><b>Przy zamawianiu części zamiennych:</b> Zamiennych podań z tabliczki znamionowej numer zamówienia ①, numer bramy ②, numer produktu ③, Typ Bramy ④, rok produkcji ⑤ i numer części zamiennej.</p>	<p><b>Höhe [mm]:</b> <b>Height [mm]:</b> <b>Hauteur [mm]:</b></p>
<b>MAGYAR</b>	<p><b>Tartalékalkatrész rendeléseknél:</b> A tipustábláról kérjük megadni a szerződés számát: ①, a kapu számát: ②, termékszámot: ③, a kapu típusát: ④, a gyártási évet: ⑤, az alkatrész cikkszámával együtt.</p>	<p><b>Beschlag:</b> <b>Track applikation:</b> <b>Type de ferrure:</b></p>
<b>ČESKY</b>	<p><b>Při objednávání náhradních dílů:</b> zároveň s číslem náhradního dílu uveďte z typového štítku číslo zakázky: ①, číslo vrat: ②, výrobní číslo: ③, typ vrat: ④, rok výroby: ⑤ .</p>	<p><b>Höherführung [mm]:</b> <b>Highlift tracks [mm]:</b> <b>Rails rehausse [mm]:</b></p>
<b>РУССКИЙ</b>	<p><b>При заказе запасных частей:</b> номер заказа: ①, номер ворот: ②, номер продукта: ③ тип: ④, год выпуска: ⑤ вместе с номером артикула запасной части.</p>	<p><b>Flügelgewicht [kg]:</b> <b>Door weight [kg]:</b> <b>Poids de la porte [kg]:</b></p>
<b>SLOVENSKO</b>	<p><b>Pri naročanju rezervnih delov navedite:</b> številko naročila ①, številko vrat ②, tip vrat ③, številko proizvoda ④, leto proizvodnje vrat ⑤. Podatke odčitajte iz tablice na vratih in dodajte številke rezervnih delov iz šifranta.</p>	<p><b>Federspannung:</b> <b>No. of spring turns:</b> Min. <b>Nombre de tours:</b> Max.</p>
<b>NORSK</b>	<p><b>Ved reservedelsbestilling:</b> Fra typeskiltet angives ordrenr. ①, portnr. ②, produktnr. ③, porttype ④, produktionsår ⑤ også med reservedelens artikkelnr.</p>	<p><b>Baujahr:</b> <b>Produced in:</b> ⑤ <b>Année:</b></p>
		<p><b>Federn von links nach rechts:</b> <b>Springs from left to right:</b> <b>Ressorts de gauche a droite:</b></p> <p>L R</p>

# Data Label Overview

<b>SVENSKA</b>	<b>Vid reservdelsbeställning:</b> Ange Ordernummer ①, Port-Nummer ②, Produkt-Nummer ③, Porttyp ④, Tillverkningsår ⑤ enligt typskylten samt reservdelens Produkt-Nummer och Artikel-Nummer.	
<b>SUOMI</b>	<b>Varaosatilauksen yhteydessä:</b> ilmoita varaosan tuotenumeron lisäksi tyypikilven tiedoista sopimusno: ①, oven nro: ②, tuotenro: ③, tyyppi: ④, valmistusvuosi: ⑤.	
<b>DANSK</b>	<b>Ved reservedelsbestilling:</b> Fra typeskiltet angives ordrenr ①, portnr. ②, produktnr. ③, porttype ④, produktionsår ⑤ tillige med reservedelens artikelnr.	<b>Auftrags-Nr:</b> <b>Order No:</b> <b>No. de fabrication:</b> ①
<b>SLOVENSKY</b>	<b>Pri objednávání náhradných dielov:</b> zároveň s tovarovým číslom náhradného dielu uveďte z typového štítku číslo zákazky: ①, číslo brány: ②, výrobné číslo: ③, Typ Brány: ④, rok výroby: ⑤.	<b>Tor-Nr:</b> <b>Door No:</b> <b>No. de la porte :</b> ②
<b>TÜRKÇE</b>	<b>Yedek parça siparişlerinde:</b> Kapı üzerindeki plakada yer alan sipariş numarası ①, kapı numarası ②, ürün numarası ③, tipi ④ ve üretim yılı ⑤ bilgileri, yedek parça numarası ile birlikte belirtilmelidir.	<b>Produkt-Nr:</b> <b>Product No:</b> <b>No. de produit:</b> ③
<b>LIETUVIŲ KALBA</b>	<b>Užsakydami atsargines dalis:</b> iš duomenų lentelės kartu su atsarginės dalies artikulo numeriu pateikite: užsakymo Nr.: ①, vartų Nr.: ②, gaminio Nr.: ③, tipą: ④, pagaminimo metus: ⑤.	<b>Typ:</b> <b>Type:</b> <b>Type:</b> ④
<b>EESTI</b>	<b>Varuosade tellimisel:</b> Märkige ukse andmeplaadilt üles tehase nr: ①, ukse nr: ②, toote nr: ③, tüüp: ④, tootmisaasta: ⑤ ning saatke need tellimisel koos varuosa artiklumberiga kaasa.	<b>Breite [mm]:</b> <b>Width [mm]:</b> <b>Largeur [mm]:</b>
<b>LATVIEŠU VALODA</b>	<b>Pasūtot rezerves daļas:</b> no tehnisko datu plāksnītes, pasūtījuma Nr.: ①, vārtu Nr.: ②, izstrādājuma Nr.: ③, modeli: ④, izgatavošanas gadu: ⑤ norādīt kopā ar rezerves daļas preces numuru.	<b>Höhe [mm]:</b> <b>Height [mm]:</b> <b>Hauteur [mm]:</b>
<b>HRVATSKI</b>	<b>Kod narudžbe rezervnih dijelova:</b> Iz pločice podataka T upisati broj narudžbe: ①, broj vrata: ②, broj proizvoda: ③, tip vrata: ④, godinu proizvodnje: ⑤ zajedno s šifrom rezervnog dijela.	<b>Beschlag:</b> <b>Track applikation:</b> <b>Type de ferrure:</b>
<b>SRPSKI</b>	<b>Prilikom porudžbine rezervnih delova:</b> navedite zajedno sa brojem artikla i broj naloga: ①, broj vrata: ②, broj proizvoda: ③, tip: ④ i godinu proizvodnje: ⑤ od tablice sa oznakom tipa.	<b>Höherführung [mm]:</b> <b>Highlift tracks [mm]:</b> <b>Rails rehausse [mm]:</b>
<b>ΕΛΛΗΝΙΚΑ</b>	<b>Κατά την παραγγελία ανταλλακτικών:</b> Παρακαλούμε αναφέρετε τον αριθμό παραγγελίας ①, τον αριθμό της πόρτας ②, τον αριθμό προϊόντος ③, τον τύπο της πόρτας ④, το έτος παραγωγής ⑤ και τον αριθμό τον ανταλλακτικού.	<b>Flügelgewicht [kg]:</b> <b>Door weight [kg]:</b> <b>Poids de la porte [kg]:</b>
<b>ROMÂNĂ</b>	<b>Pentru comenzi de piese de schimb:</b> Vă rugăm să specificați de pe plăcuța produsului Nr. comandă ①, Nr. poartă ②, Nr. produs ③, Tipul porții ④, Anul de fabricație ⑤, cât și Nr. de articol al produsului de comandat.	<b>Federspannung:</b> <b>No. of spring turns:</b> <b>Min.</b> <b>Nombre de tours:</b> <b>Max.</b>
<b>БЪЛГАРСКИ</b>	<b>При поръчка на резервни части:</b> Заедно с номера на артикула посочвайте и данните от типовата табелка, поръчка No.: ①, врата No.: ②, продукт No.: ③, тип: ④, година на производство: ⑤.	<b>Baujahr:</b> <b>Produced in:</b> ⑤ <b>Année:</b>
		<b>Federn von links nach rechts:</b> <b>Springs from left to right:</b> <b>Ressorts de gauche a droite:</b>  L R

# 1. Double-Skinned Door Sections 42 mm

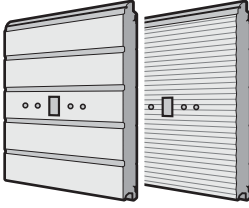
Article	Description	Production period	Art. no.	Qty.	€
	<p><b>* Bottom door section, double-skinned</b></p> <p>S-ribbed, Stucco L-ribbed, Micrograin Based on RAL _____ Surcharge per ventilation grille</p> <p><b>Door section height:</b>  <input type="checkbox"/> 375      <input type="checkbox"/> 500  <input type="checkbox"/> 625      <input type="checkbox"/> 750</p>	<p>09.07.2001 – 28.02.2013 01.02.2009 – 28.02.2013</p>	<p>3056063 3081048 _____ 3041072</p>	<p>Units _____ _____ _____ _____</p>	<p>/m<sup>2</sup> /m<sup>2</sup> +<sup>1</sup> /each</p>
	<p><b>* Bottom door section, double-skinned, for special heights, adapted section (cut straight or chamfered)</b></p> <p>S-ribbed, Stucco L-ribbed, Micrograin Based on RAL _____ Surcharge per ventilation grille</p> <p><b>Door section height:</b> _____</p>	<p>09.07.2001 – 28.02.2013 01.02.2009 – 28.02.2013</p>	<p>3059757 3081049 _____ 3041072</p>	<p>Units _____ _____ _____ _____</p>	<p>/m<sup>2</sup> /m<sup>2</sup> +<sup>1</sup> /each</p>
	<p><b>* Door section, double-skinned</b></p> <p>S-ribbed, Stucco L-ribbed, Micrograin Based on RAL _____ Surcharge per ventilation grille</p> <p><b>Door section height:</b>  <input type="checkbox"/> 375      <input type="checkbox"/> 500  <input type="checkbox"/> 625      <input type="checkbox"/> 750</p>	<p>09.07.2001 – 28.02.2013 01.02.2009 – 28.02.2013</p>	<p>3056065 3081050 _____ 3041072</p>	<p>Units _____ _____ _____ _____</p>	<p>/m<sup>2</sup> /m<sup>2</sup> +<sup>1</sup> /each</p>
	<p><b>* Door section, double-skinned, with hole pattern for door lock</b></p> <p>S-ribbed, Stucco L-ribbed, Micrograin Based on RAL _____ Surcharge per ventilation grille</p> <p><b>Door section height:</b>  <input type="checkbox"/> 375      <input type="checkbox"/> 500  <input type="checkbox"/> 625      <input type="checkbox"/> 750</p>	<p>09.07.2001 – 28.02.2013 01.02.2009 – 28.02.2013</p>	<p>3056066 3081051 _____ 3041072</p>	<p>Units _____ _____ _____ _____</p>	<p>/m<sup>2</sup> /m<sup>2</sup> +<sup>1</sup> /each</p>

+<sup>1</sup> Surcharge for door sections in preferred colour and RAL to choose, see pages 135 – 136 / indicate RAL colour article number

+<sup>2</sup> Surcharge for compound glazing, see page 83 – 84 / indicate the article number for the respective compound glazing

<b>ORDER</b>	Customer no.:	Order no./com.:	<b>*Please take information from the data label!</b>	
			Order no.:	Door no.:
	Customer name:		Product no.:	Type:
	Shipping address: _____		Year of manufacture:	
	Place/date:		Stamp and signature	

# 1. Double-Skinned Door Sections 42 mm

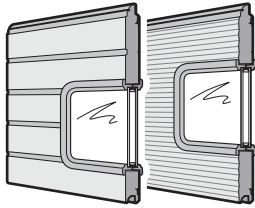
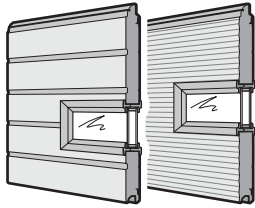
Article	Description	Production period	Art. no.	Qty.	€
	<p><b>* Door section, double-skinned, with compound glazing type A</b></p> <p>S-ribbed, Stucco L-ribbed, Micrograin Based on RAL _____ Compound glazing version</p> <p><b>Door section height:</b>  <input type="checkbox"/> 500    <input type="checkbox"/> 625    <input type="checkbox"/> 750</p> <p><b>Glazing position:</b> (only in centre with Micrograin)  <input type="checkbox"/> 1    <input type="checkbox"/> 2    <input type="checkbox"/> 3</p>	<p>09.07.2001 – 28.02.2013 01.02.2009 – 28.02.2013</p>	<p>3056067 3081052</p>	<p>Units</p> <p>_____ _____ _____</p>	<p>/m<sup>2</sup> /m<sup>2</sup> +<sup>1</sup> +<sup>2</sup></p>
	<p><b>* Door section, double-skinned, ribbed, with compound glazing type C</b></p> <p>Based on RAL _____ Compound glazing type C</p> <p><b>Door section height:</b>  <input type="checkbox"/> 500    <input type="checkbox"/> 625    <input type="checkbox"/> 750</p> <p><b>Glazing position:</b>  <input type="checkbox"/> 1    <input type="checkbox"/> 2    <input type="checkbox"/> 3</p>	<p>09.07.2001 – 31.01.2009</p>	<p>3056068 3047150</p>	<p>Units</p> <p>_____ _____ _____</p>	<p>/m<sup>2</sup> +<sup>1</sup> /each</p>
	<p><b>* Door section, double-skinned, with compound glazing type D</b></p> <p>S-ribbed, Stucco L-ribbed, Micrograin Based on RAL _____ Compound glazing version</p> <p><b>Door section height:</b>  <input type="checkbox"/> 500    <input type="checkbox"/> 625    <input type="checkbox"/> 750</p> <p><b>Glazing position:</b> (only in centre with Micrograin)  <input type="checkbox"/> 1    <input type="checkbox"/> 2    <input type="checkbox"/> 3</p>	<p>09.07.2001 – 28.02.2013 01.02.2009 – 28.02.2013</p>	<p>3056069 3081053</p>	<p>Units</p> <p>_____ _____ _____</p>	<p>/m<sup>2</sup> /m<sup>2</sup> +<sup>1</sup> +<sup>2</sup></p>
	<p><b>* Door section, double-skinned, with compound glazing type D</b></p> <p>S-ribbed, Stucco L-ribbed, Micrograin Based on RAL _____ Compound glazing version</p> <p><b>Door section height:</b>  <input type="checkbox"/> 500    <input type="checkbox"/> 625    <input type="checkbox"/> 750</p> <p><b>Glazing position:</b> (only in centre with Micrograin)  <input type="checkbox"/> 1    <input type="checkbox"/> 2    <input type="checkbox"/> 3</p>	<p>09.07.2001 – 28.02.2013 01.02.2009 – 28.02.2013</p>	<p>3056069 3081053</p>	<p>Units</p> <p>_____ _____ _____</p>	<p>/m<sup>2</sup> /m<sup>2</sup> +<sup>1</sup> +<sup>2</sup></p>

+<sup>1</sup> Surcharge for door sections in preferred colour and RAL to choose, see pages 135 – 136/indicate RAL colour article number

+<sup>2</sup> Surcharge for compound glazing, see page 83 – 84/indicate the article number for the respective compound glazing

<b>ORDER</b>	Customer no.: _____	Order no./com.: _____	<b>*Please take information from the data label!</b>	
	Customer name: _____	Shipping address: _____	Order no.: _____	Door no.: _____
	Place/date: _____	Stamp and signature _____	Product no.: _____	Type: _____
			Year of manufacture: _____	

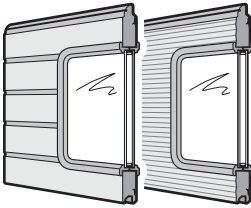
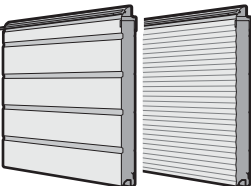
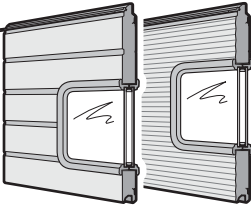

# 1. Double-Skinned Door Sections 42 mm

Article	Description	Production period	Art. no.	Qty.	€
	<p><b>* Door section, double-skinned, with compound glazing type E</b></p> <p>S-ribbed, Stucco L-ribbed, Micrograin Based on RAL _____ Compound glazing version</p> <p><b>Door section height:</b> <input type="checkbox"/> 625    <input type="checkbox"/> 750</p> <p><b>Glazing position:</b> (only in centre with Micrograin) <input type="checkbox"/> 1    <input type="checkbox"/> 2</p>	<p>09.07.2001 – 28.02.2013 01.02.2009 – 28.02.2013</p>	<p>3056070 3086401</p>	<p>Units</p> <p>_____ _____ _____ _____</p>	<p>/m<sup>2</sup> /m<sup>2</sup> +1 +2</p>
	<p><b>* Top door section, double-skinned, with lintel seal</b></p> <p>S-ribbed, Stucco L-ribbed, Micrograin Based on RAL _____</p> <p><b>Door section height:</b> <input type="checkbox"/> 375    <input type="checkbox"/> 500 <input type="checkbox"/> 625    <input type="checkbox"/> 750</p>	<p>09.07.2001 – 28.02.2013 01.02.2009 – 28.02.2013</p>	<p>3056071 3081054</p>	<p>Units</p> <p>_____ _____ _____</p>	<p>/m<sup>2</sup> /m<sup>2</sup> +1</p>
	<p><b>* Top door section, double-skinned, for intermediate height, with lintel seal</b></p> <p>S-ribbed, Stucco L-ribbed, Micrograin Based on RAL _____</p> <p><b>Door section height:</b> _____</p>	<p>09.07.2001 – 28.02.2013 01.02.2009 – 28.02.2013</p>	<p>3054452 3081055</p>	<p>Units</p> <p>_____ _____ _____</p>	<p>/m<sup>2</sup> /m<sup>2</sup> +1</p>
	<p><b>* Top door section, double-skinned, with compound glazing type A, with lintel seal</b></p> <p>S-ribbed, Stucco L-ribbed, Micrograin Based on RAL _____ Compound glazing version</p> <p><b>Door section height:</b> <input type="checkbox"/> 500    <input type="checkbox"/> 625    <input type="checkbox"/> 750</p> <p><b>Glazing position:</b> (only in centre with Micrograin) <input type="checkbox"/> 1    <input type="checkbox"/> 2    <input type="checkbox"/> 3</p>	<p>09.07.2001 – 28.02.2013 01.02.2009 – 28.02.2013</p>	<p>3056073 3081056</p>	<p>Units</p> <p>_____ _____ _____</p>	<p>/m<sup>2</sup> /m<sup>2</sup> +1 +2</p>

+1 Surcharge for door sections in preferred colour and RAL to choose, see pages 135 – 136 / indicate RAL colour article number  
+2 Surcharge for compound glazing, see page 83 – 84 / indicate the article number for the respective compound glazing

<b>ORDER</b>	Customer no.: _____	Order no./com.: _____	<b>*Please take information from the data label!</b>	
			Order no.:	Door no.:
	Customer name: _____		Product no.:	Type:
	Shipping address: _____		Year of manufacture:	
	Place/date: _____		Stamp and signature	

# 1. Double-Skinned Door Sections 42 mm

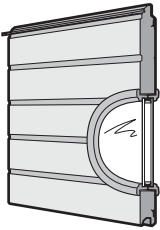
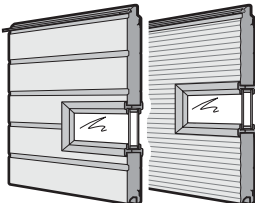
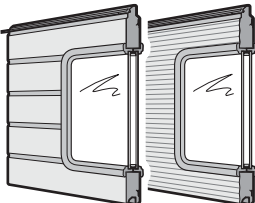
Article	Description	Production period	Art. no.	Qty.	€
	<p><b>* Top door section, double-skinned, ribbed, with compound glazing type C, with lintel seal</b></p> <p>Based on RAL _____ Compound glazing type C</p> <p><b>Door section height:</b>  <input type="checkbox"/> 500    <input type="checkbox"/> 625    <input type="checkbox"/> 750</p> <p><b>Glazing position:</b>  <input type="checkbox"/> 1    <input type="checkbox"/> 2    <input type="checkbox"/> 3</p>	09.07.2001 – 31.01.2009	3056074	Units	/m <sup>2</sup>  + <sup>1</sup> /each
			3047150		
	<p><b>* Top door section, double-skinned, with compound glazing type D, with lintel seal</b></p> <p>S-ribbed, Stucco L-ribbed, Micrograin Based on RAL _____ Compound glazing version</p> <p><b>Door section height:</b>  <input type="checkbox"/> 500    <input type="checkbox"/> 625    <input type="checkbox"/> 750</p> <p><b>Glazing position:</b> (only in centre with Micrograin)  <input type="checkbox"/> 1    <input type="checkbox"/> 2    <input type="checkbox"/> 3</p>	09.07.2001 – 28.02.2013 01.02.2009 – 28.02.2013	3056075 3081057	Units	/m <sup>2</sup> /m <sup>2</sup> + <sup>1</sup> + <sup>2</sup>
	<p><b>* Top door section, double-skinned, with compound glazing type E, with lintel seal</b></p> <p>S-ribbed, Stucco L-ribbed, Micrograin Based on RAL _____ Compound glazing version</p> <p><b>Door section height:</b>  <input type="checkbox"/> 625    <input type="checkbox"/> 750</p> <p><b>Glazing position:</b> (only in centre with Micrograin)  <input type="checkbox"/> 1    <input type="checkbox"/> 2</p>	09.07.2001 – 28.02.2013 01.02.2009 – 28.02.2013	3056076 3086402	Units	/m <sup>2</sup> /m <sup>2</sup> + <sup>1</sup> + <sup>2</sup>

+<sup>1</sup> Surcharge for door sections in preferred colour and RAL to choose, see pages 135 – 136/indicate RAL colour article number

+<sup>2</sup> Surcharge for compound glazing, see page 83 – 84/indicate the article number for the respective compound glazing

<b>ORDER</b>	Customer no.: _____	Order no./com.: _____	<b>*Please take information from the data label!</b>	
			Order no.:	Door no.:
	Customer name: _____		Product no.:	Type:
	Shipping address: _____		Year of manufacture:	
	Place/date: _____		Stamp and signature	

# 1. Double-Skinned Door Sections 42 mm

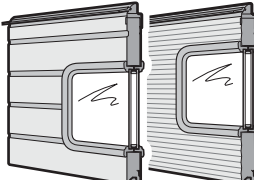
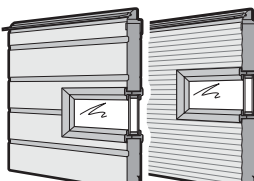
Article	Description	Production period	Art. no.	Qty.	€	
	<p><b>* Top door section, double-skinned, for intermediate height, with compound glazing type A, with lintel seal</b></p> <p>S-ribbed, Stucco L-ribbed, Micrograin Based on RAL _____ Compound glazing version</p> <p><b>Door section height</b> _____</p> <p><b>Glazing position:</b> (only in centre with Micrograin) <input type="checkbox"/> 1    <input type="checkbox"/> 2    <input type="checkbox"/> 3</p>	09.07.2001 – 28.02.2013 01.02.2009 – 28.02.2013	3056077 3081058 _____ _____	Units _____ _____ _____ _____	_____ _____ +1 +2	
	<p><b>* Top door section, double-skinned, ribbed, for intermediate height, with compound glazing type C with lintel seal</b></p> <p>Based on RAL _____ Compound glazing type C</p> <p><b>Door section height</b> _____</p> <p><b>Glazing position:</b> <input type="checkbox"/> 1    <input type="checkbox"/> 2    <input type="checkbox"/> 3</p>	09.07.2001 – 31.01.2009	3056078 _____ 3047150	Units _____ _____ _____	_____ _____ +1 /each	
		<p><b>* Top door section, double-skinned, for intermediate height, with compound glazing type D, with lintel seal</b></p> <p>S-ribbed, Stucco L-ribbed, Micrograin Based on RAL _____ Compound glazing version</p> <p><b>Door section height</b> _____</p> <p><b>Glazing position:</b> (only in centre with Micrograin) <input type="checkbox"/> 1    <input type="checkbox"/> 2    <input type="checkbox"/> 3</p>	09.07.2001 – 28.02.2013 01.02.2009 – 28.02.2013	3056079 3081059 _____ _____	Units _____ _____ _____ _____	_____ _____ +1 +2
		<p><b>* Top door section, double-skinned, for intermediate height, with compound glazing type D, with lintel seal</b></p> <p>Based on RAL _____ Compound glazing type C</p> <p><b>Door section height</b> _____</p> <p><b>Glazing position:</b> <input type="checkbox"/> 1    <input type="checkbox"/> 2    <input type="checkbox"/> 3</p>				

+1 Surcharge for door sections in preferred colour and RAL to choose, see pages 135 – 136 / indicate RAL colour article number

+2 Surcharge for compound glazing, see page 83 – 84 / indicate the article number for the respective compound glazing

<b>ORDER</b>	Customer no.: _____	Order no./com.: _____	<b>*Please take information from the data label!</b>	
			Order no.:	Door no.:
	Customer name: _____		Product no.:	Type:
	Shipping address: _____		Year of manufacture:	
	Place/date: _____		Stamp and signature	

# 1. Double-Skinned Door Sections 42 mm

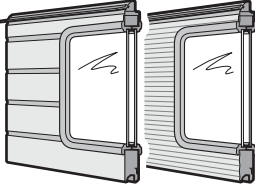
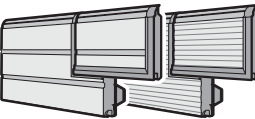
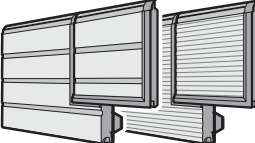
Article	Description	Production period	Art. no.	Qty.	€		
	<p><b>* Top door section, double-skinned, for intermediate height, with compound glazing type E, with lintel seal</b></p> <p>S-ribbed, Stucco L-ribbed, Micrograin Based on RAL _____ Compound glazing version</p> <p><b>Door section height _____</b></p>	09.07.2001 – 28.02.2013 01.02.2009 – 28.02.2013	3056080 3086403 _____ _____	Units _____ _____ _____ _____	_____ _____ +1 +2		
		<p><b>* Bottom door section, double-skinned, 375, with wicket door made of sections, with aluminium reinforcement profile</b></p> <p><b>Up to door widths of 4500 mm:</b> S-ribbed, Stucco L-ribbed, Micrograin</p> <p><b>From door widths of 4510 mm to 5500 mm:</b> S-ribbed, Stucco L-ribbed, Micrograin Based on RAL _____ Surcharge per ventilation grille</p>	09.07.2001 – 28.02.2013 01.02.2009 – 28.02.2013  09.07.2001 – 28.02.2013 01.02.2009 – 28.02.2013	3087600 3087634  3087601 3087635  3041072	Units _____ _____  _____ _____  _____	_____ _____  _____ _____  +1 /each	
			<p><b>* Bottom door section, double-skinned, 500, with wicket door made of sections, with aluminium reinforcement profile</b></p> <p><b>Up to door widths of 4500 mm:</b> S-ribbed, Stucco L-ribbed, Micrograin</p> <p><b>From door widths of 4510 mm to 5500 mm:</b> S-ribbed, Stucco L-ribbed, Micrograin Based on RAL _____ Surcharge per ventilation grille</p>	09.07.2001 – 28.02.2013 01.02.2009 – 28.02.2013  09.07.2001 – 28.02.2013 01.02.2009 – 28.02.2013	3087602 3087636  3087603 3087637  3041072	Units _____ _____  _____ _____  _____	_____ _____  _____ _____  +1 /each

+1 Surcharge for door sections in preferred colour and RAL to choose, see pages 135 – 136/indicate RAL colour article number

+2 Surcharge for compound glazing, see page 83 – 84/indicate the article number for the respective compound glazing

<b>ORDER</b>	Customer no.: _____	Order no./com.: _____	<b>*Please take information from the data label!</b>	
			Order no.:	Door no.:
	Customer name: _____		Product no.:	Type:
	Shipping address: _____		Year of manufacture:	
	Place/date: _____		Stamp and signature	

# 1. Double-Skinned Door Sections 42 mm

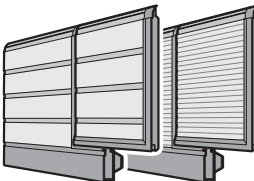
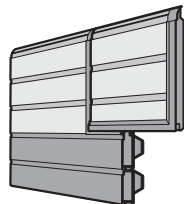
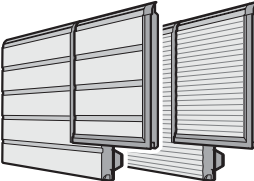
Article	Description	Production period	Art. no.	Qty.	€
	<p><b>* Bottom door section, double-skinned, 625, with wicket door made of sections 500, with aluminium bottom profile, up to door widths of 5500 mm</b></p> <p>S-ribbed, Stucco L-ribbed, Micrograin Based on RAL _____ Surcharge per ventilation grille</p>	09.07.2001 – 28.02.2013	3087604	Units	/m <sup>2</sup>
		01.02.2009 – 28.02.2013	3087638		/m <sup>2</sup>
			3041072		+ <sup>1</sup>
					/each
	<p><b>* Bottom door section, double-skinned, 625, ribbed, with wicket door made of sections 375, with aluminium bottom profile, from door widths of 5510 mm</b></p> <p>Based on RAL _____ Surcharge per ventilation grille</p>	09.07.2001 – 28.02.2013	3087594	Units	/m <sup>2</sup>
					+ <sup>1</sup>
			3041072		/each
	<p><b>* Bottom door section, double-skinned, 625, with wicket door made of sections, with aluminium reinforcement profile</b></p> <p><b>Up to door widths of 4500 mm:</b> S-ribbed, Stucco L-ribbed, Micrograin</p> <p><b>From door widths of 4510 mm to 5500 mm:</b> S-ribbed, Stucco L-ribbed, Micrograin Based on RAL _____ Surcharge per ventilation grille</p>	09.07.2001 – 28.02.2013	3087605	Units	/m <sup>2</sup>
		01.02.2009 – 28.02.2013	3087639		/m <sup>2</sup>
		09.07.2001 – 28.02.2013	3087606		/m <sup>2</sup>
		01.02.2009 – 28.02.2013	3087640		/m <sup>2</sup>
					+ <sup>1</sup>
			3041072		/each

+<sup>1</sup> Surcharge for door sections in preferred colour and RAL to choose, see pages 135 – 136 / indicate RAL colour article number

+<sup>2</sup> Surcharge for compound glazing, see page 83 – 84 / indicate the article number for the respective compound glazing

<b>ORDER</b>	Customer no.: _____	Order no./com.: _____	<b>*Please take information from the data label!</b>	
			Order no.:	Door no.:
	Customer name: _____		Product no.:	Type:
	Shipping address: _____		Year of manufacture:	
	Place/date: _____		Stamp and signature	

# 1. Double-Skinned Door Sections 42 mm

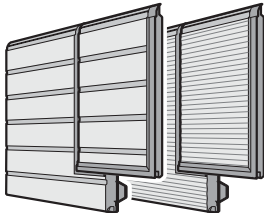
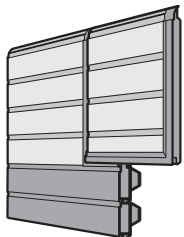
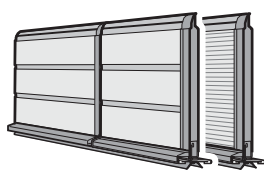
Article	Description	Production period	Art. no.	Qty.	€
	<p><b>* Bottom door section, double-skinned, 750, with wicket door made of sections, with aluminium reinforcement profile</b></p> <p><b>Up to door widths of 4500 mm:</b>            S-ribbed, Stucco            L-ribbed, Micrograin</p> <p><b>From door widths of 4510 mm to 5500 mm:</b>            S-ribbed, Stucco            L-ribbed, Micrograin            Based on RAL _____            Surcharge per ventilation grille</p>	<p>09.07.2001 – 28.02.2013            01.02.2009 – 28.02.2013</p>	<p>3087607            3087641</p>	<p>Units            _____            _____</p>	<p>/m<sup>2</sup>            /m<sup>2</sup></p>
	<p><b>* Bottom door section, double-skinned, 750, ribbed, with wicket door made of sections 500, with aluminium bottom profile, from door widths of 5510 mm</b>            Based on RAL _____            Surcharge per ventilation grille</p>	<p>09.07.2001 – 28.02.2013</p>	<p>3087595            3041072</p>	<p>Units            _____            _____</p>	<p>/m<sup>2</sup>            +<sup>1</sup>            /each</p>
	<p><b>* Bottom door section, double-skinned, 375, with wicket door with trip-free threshold, made of sections with stainless steel bottom profile, up to door widths of 5500 mm</b>            S-ribbed, Stucco            L-ribbed, Micrograin            Based on RAL _____            Surcharge per ventilation grille</p>	<p>01.05.2005 – 28.02.2013            01.02.2009 – 28.02.2013</p>	<p>3087609            3087643            3041072</p>	<p>Units            _____            _____            _____</p>	<p>/m<sup>2</sup>            /m<sup>2</sup>            +<sup>1</sup>            /each</p>

+<sup>1</sup> Surcharge for door sections in preferred colour and RAL to choose, see pages 135 – 136/indicate RAL colour article number

+<sup>2</sup> Surcharge for compound glazing, see page 83 – 84/indicate the article number for the respective compound glazing

<b>ORDER</b>	Customer no.: _____	Order no./com.: _____	<b>*Please take information from the data label!</b>	
			Order no.:	Door no.:
	Customer name: _____		Product no.:	Type:
	Shipping address: _____		Year of manufacture:	
	Place/date: _____		Stamp and signature	

# 1. Double-Skinned Door Sections 42 mm

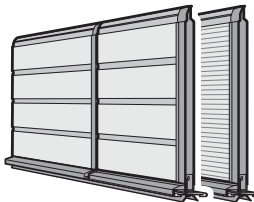
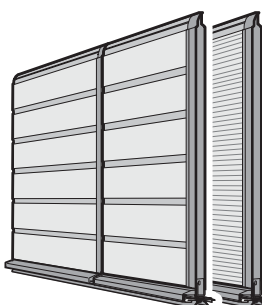
Article	Description	Production period	Art. no.	Qty.	€		
	<p><b>* Bottom door section, double-skinned, 500, with wicket door with trip-free threshold, made of sections with stainless steel bottom profile</b></p> <p><b>Up to door widths of 5500 mm:</b> S-ribbed, Stucco L-ribbed, Micrograin</p> <p><b>From door widths of 5510 mm:</b> S-ribbed, Stucco L-ribbed, Micrograin Based on RAL _____ Surcharge per ventilation grille</p>	<p>01.05.2005 – 28.02.2013</p> <p>01.02.2009 – 28.02.2013</p>	<p>3087610</p> <p>3087644</p>	<p>Units</p> <p>_____</p> <p>_____</p>	<p>/m<sup>2</sup></p> <p>/m<sup>2</sup></p>		
	<p>02.11.2005 – 28.02.2013</p> <p>01.02.2009 – 28.02.2013</p>	<p>3087611</p> <p>3087645</p>	<p>_____</p> <p>_____</p>	<p>/m<sup>2</sup></p> <p>/m<sup>2</sup></p>			
	<p>_____</p> <p>_____</p>	<p>_____</p> <p>_____</p>	<p>_____</p> <p>_____</p>	<p>+<sup>1</sup></p>			
	<p>_____</p> <p>_____</p>	<p>3041072</p>	<p>_____</p> <p>_____</p>	<p>/each</p>			
	<p><b>* Bottom door section, double-skinned, 625, with wicket door with trip-free threshold, made of sections with stainless steel bottom profile</b></p> <p><b>Up to door widths of 5500 mm:</b> S-ribbed, Stucco L-ribbed, Micrograin</p> <p><b>From door widths of 5510 mm:</b> S-ribbed, Stucco L-ribbed, Micrograin Based on RAL _____ Surcharge per ventilation grille</p>					<p>Units</p> <p>_____</p> <p>_____</p>	<p>/m<sup>2</sup></p> <p>/m<sup>2</sup></p>
	<p>01.05.2005 – 28.02.2013</p> <p>01.02.2009 – 28.02.2013</p>	<p>3087612</p> <p>3087646</p>	<p>_____</p> <p>_____</p>	<p>/m<sup>2</sup></p> <p>/m<sup>2</sup></p>			
<p>02.11.2005 – 28.02.2013</p> <p>01.02.2009 – 28.02.2013</p>	<p>3087613</p> <p>3087647</p>	<p>_____</p> <p>_____</p>	<p>/m<sup>2</sup></p> <p>/m<sup>2</sup></p>				
<p>_____</p> <p>_____</p>	<p>_____</p> <p>_____</p>	<p>_____</p> <p>_____</p>	<p>+<sup>1</sup></p>				
<p>_____</p> <p>_____</p>	<p>3041072</p>	<p>_____</p> <p>_____</p>	<p>/each</p>				
	<p><b>* Bottom door section, double-skinned, 750, with wicket door with trip-free threshold, made of sections with stainless steel bottom profile</b></p> <p><b>Up to door widths of 5500 mm:</b> S-ribbed, Stucco L-ribbed, Micrograin</p> <p><b>From door widths of 5510 mm:</b> S-ribbed, Stucco L-ribbed, Micrograin Based on RAL _____ Surcharge per ventilation grille</p>	<p>01.05.2005 – 28.02.2013</p> <p>01.02.2009 – 28.02.2013</p>	<p>3087614</p> <p>3087648</p>	<p>Units</p> <p>_____</p> <p>_____</p>	<p>/m<sup>2</sup></p> <p>/m<sup>2</sup></p>		
	<p>02.11.2005 – 28.02.2013</p> <p>01.02.2009 – 28.02.2013</p>	<p>3087615</p> <p>3087649</p>	<p>_____</p> <p>_____</p>	<p>/m<sup>2</sup></p> <p>/m<sup>2</sup></p>			
	<p>_____</p> <p>_____</p>	<p>_____</p> <p>_____</p>	<p>_____</p> <p>_____</p>	<p>+<sup>1</sup></p>			
	<p>_____</p> <p>_____</p>	<p>3041072</p>	<p>_____</p> <p>_____</p>	<p>/each</p>			

+<sup>1</sup> Surcharge for door sections in preferred colour and RAL to choose, see pages 135 – 136 / indicate RAL colour article number

+<sup>2</sup> Surcharge for compound glazing, see page 83 – 84 / indicate the article number for the respective compound glazing

<b>ORDER</b>	Customer no.: _____	Order no./com.: _____	<b>*Please take information from the data label!</b>	
			Order no.:	Door no.:
	Customer name: _____		Product no.:	Type:
	Shipping address: _____		Year of manufacture:	
	Place/date: _____		Stamp and signature	

# 1. Double-Skinned Door Sections 42 mm

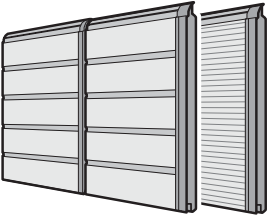
Article	Description	Production period	Art. no.	Qty.	€
	<p><b>* Door section, double-skinned, with wicket door</b></p> <p>S-ribbed, Stucco L-ribbed, Micrograin Based on RAL _____ Surcharge per ventilation grille</p> <p><b>Door section height:</b>  <input type="checkbox"/> 375    <input type="checkbox"/> 500  <input type="checkbox"/> 625    <input type="checkbox"/> 750</p>	<p>09.07.2001 – 28.02.2013 01.02.2009 – 28.02.2013</p>	<p>3087616 3087650 _____ 3041072</p>	<p>Units _____ _____ _____ _____</p>	<p>_____ _____ _____ _____</p> <p>/m<sup>2</sup> /m<sup>2</sup> +<sup>1</sup> /each</p>
	<p><b>* Door section, double-skinned, with wicket door for lock</b></p> <p>S-ribbed, Stucco L-ribbed, Micrograin Based on RAL _____ Surcharge per ventilation grille</p> <p><b>Door section height:</b>  <input type="checkbox"/> 500    <input type="checkbox"/> 625    <input type="checkbox"/> 750</p>	<p>09.07.2001 – 28.02.2013 01.02.2009 – 28.02.2013</p>	<p>3087617 3087651 _____ 3041072</p>	<p>Units _____ _____ _____ _____</p>	<p>_____ _____ _____ _____</p> <p>/m<sup>2</sup> /m<sup>2</sup> +<sup>1</sup> /each</p>
	<p><b>* Door section, double-skinned, with compound glazing type A, with wicket door</b></p> <p>S-ribbed, Stucco L-ribbed, Micrograin Based on RAL _____ Compound glazing version</p> <p><b>Door section height:</b>  <input type="checkbox"/> 500    <input type="checkbox"/> 625    <input type="checkbox"/> 750</p> <p><b>Glazing position:</b> (only in centre with Micrograin)  <input type="checkbox"/> 1    <input type="checkbox"/> 2    <input type="checkbox"/> 3</p>	<p>09.07.2001 – 28.02.2013 01.02.2009 – 28.02.2013</p>	<p>3087618 3087652 _____ _____</p>	<p>Units _____ _____ _____ _____</p>	<p>_____ _____ _____ _____</p> <p>/m<sup>2</sup> /m<sup>2</sup> +<sup>1</sup> +<sup>2</sup></p>

+<sup>1</sup> Surcharge for door sections in preferred colour and RAL to choose, see pages 135 – 136/indicate RAL colour article number

+<sup>2</sup> Surcharge for compound glazing, see page 83 – 84/indicate the article number for the respective compound glazing

<b>ORDER</b>	Customer no.: _____	Order no./com.: _____	<b>*Please take information from the data label!</b>	
			Order no.:	Door no.:
	Customer name: _____		Product no.:	Type:
	Shipping address: _____		Year of manufacture:	
Place/date: _____		Stamp and signature _____		

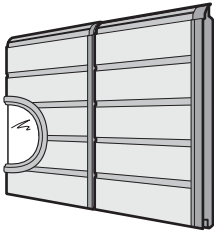
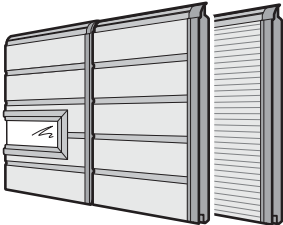
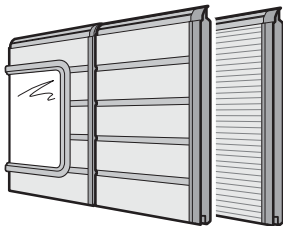

# 1. Double-Skinned Door Sections 42 mm

Article	Description	Production period	Art. no.	Qty.	€
	<p><b>* Door section, double-skinned, ribbed, with compound glazing type C, with wicket door</b> Based on RAL _____ Compound glazing type C</p> <p><b>Door section height:</b>  <input type="checkbox"/> 500    <input type="checkbox"/> 625    <input type="checkbox"/> 750</p> <p><b>Glazing position:</b>  <input type="checkbox"/> 1    <input type="checkbox"/> 2    <input type="checkbox"/> 3</p>	09.07.2001 – 31.01.2009	3087596	Units	/m <sup>2</sup> +1 /each
			3047150		
	<p><b>* Door section, double-skinned, with compound glazing type D, with wicket door</b></p> <p>S-ribbed, Stucco L-ribbed, Micrograin Based on RAL _____ Compound glazing version</p> <p><b>Door section height:</b>  <input type="checkbox"/> 500    <input type="checkbox"/> 625    <input type="checkbox"/> 750</p> <p><b>Glazing position:</b> (only in centre with Micrograin)  <input type="checkbox"/> 1    <input type="checkbox"/> 2    <input type="checkbox"/> 3</p>	09.07.2001 – 28.02.2013	3087619	Units	/m <sup>2</sup> /m <sup>2</sup> +1 +2
		01.02.2009 – 28.02.2013	3087653		
	<p><b>* Door section, double-skinned, with compound glazing type E, with wicket door</b></p> <p>S-ribbed, Stucco L-ribbed, Micrograin Based on RAL _____ Compound glazing version</p> <p><b>Door section height:</b>  <input type="checkbox"/> 625    <input type="checkbox"/> 750</p> <p><b>Glazing position:</b> (only in centre with Micrograin)  <input type="checkbox"/> 1    <input type="checkbox"/> 2</p>	09.07.2001 – 28.02.2013	3087620	Units	/m <sup>2</sup> /m <sup>2</sup> +1 +2
		01.02.2009 – 28.02.2013	3087654		

+1 Surcharge for door sections in preferred colour and RAL to choose, see pages 135 – 136 / indicate RAL colour article number  
 +2 Surcharge for compound glazing, see page 83 – 84 / indicate the article number for the respective compound glazing

<b>ORDER</b>	Customer no.: _____	Order no./com.: _____	<b>*Please take information from the data label!</b>	
			<b>Order no.:</b> _____	<b>Door no.:</b> _____
	Customer name: _____		<b>Product no.:</b> _____	<b>Type:</b> _____
	Shipping address: _____		<b>Year of manufacture:</b> _____	
	Place/date: _____		Stamp and signature _____	

# 1. Double-Skinned Door Sections 42 mm

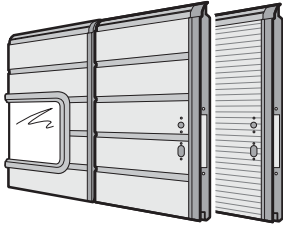
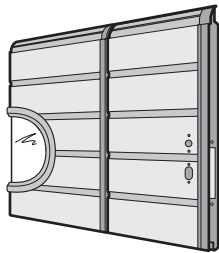
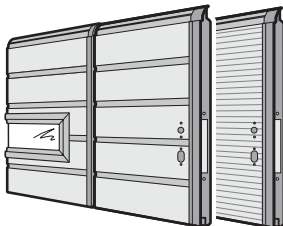
Article	Description	Production period	Art. no.	Qty.	€		
	<p><b>* Door section, double-skinned, with compound glazing type A, with wicket door for lock</b></p> <p>S-ribbed, Stucco L-ribbed, Micrograin Based on RAL _____ Compound glazing version</p> <p><b>Door section height:</b>  <input type="checkbox"/> 500    <input type="checkbox"/> 625    <input type="checkbox"/> 750</p> <p><b>Glazing position:</b> (only in centre with Micrograin)  <input type="checkbox"/> 1    <input type="checkbox"/> 2    <input type="checkbox"/> 3</p>	<p>09.07.2001 – 28.02.2013 01.02.2009 – 28.02.2013</p>	<p>3087621 3087655</p>	<p>Units</p> <p>_____ _____ _____ _____</p>	<p>/m<sup>2</sup> /m<sup>2</sup> +<sup>1</sup> +<sup>2</sup></p>		
		<p><b>* Door section, double-skinned, ribbed, with compound glazing type C, with wicket door for lock</b></p> <p>Based on RAL _____ Compound glazing type C</p> <p><b>Door section height:</b>  <input type="checkbox"/> 500    <input type="checkbox"/> 625    <input type="checkbox"/> 750</p> <p><b>Glazing position:</b>  <input type="checkbox"/> 1    <input type="checkbox"/> 2    <input type="checkbox"/> 3</p>	<p>09.07.2001 – 31.01.2009</p>	<p>3087597 3047150</p>	<p>Units</p> <p>_____ _____ _____</p>	<p>/m<sup>2</sup> +<sup>1</sup> /each</p>	
			<p><b>* Door section, double-skinned, with compound glazing type D, with wicket door for lock</b></p> <p>S-ribbed, Stucco L-ribbed, Micrograin Based on RAL _____ Compound glazing version</p> <p><b>Door section height:</b>  <input type="checkbox"/> 500    <input type="checkbox"/> 625    <input type="checkbox"/> 750</p> <p><b>Glazing position:</b> (only in centre with Micrograin)  <input type="checkbox"/> 1    <input type="checkbox"/> 2    <input type="checkbox"/> 3</p>	<p>09.07.2001 – 28.02.2013 01.02.2009 – 28.02.2013</p>	<p>3087622 3087656</p>	<p>Units</p> <p>_____ _____ _____</p>	<p>/m<sup>2</sup> /m<sup>2</sup> +<sup>1</sup> +<sup>2</sup></p>
			<p>_____</p>	<p>_____</p>	<p>_____</p>	<p>_____</p>	

+<sup>1</sup> Surcharge for door sections in preferred colour and RAL to choose, see pages 135 – 136/indicate RAL colour article number  
 +<sup>2</sup> Surcharge for compound glazing, see page 83 – 84/indicate the article number for the respective compound glazing

<b>ORDER</b>	Customer no.:	Order no./com.:	<b>*Please take information from the data label!</b>	
			Order no.:	Door no.:
	Customer name:		Product no.:	Type:
	Shipping address: _____		Year of manufacture:	
	Place/date:		Stamp and signature	

# 1. Double-Skinned Door Sections 42 mm

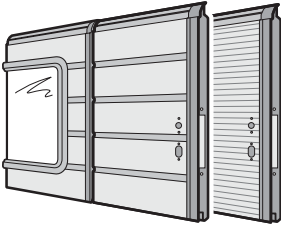
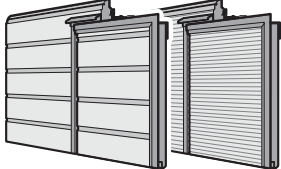
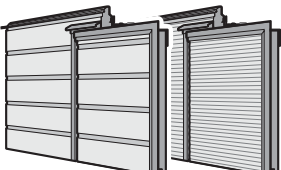
Article	Description	Production period	Art. no.	Qty.	€
	<p><b>* Door section, double-skinned, with compound glazing type E, with wicket door for lock</b></p> <p>S-ribbed, Stucco L-ribbed, Micrograin Based on RAL _____ Compound glazing version</p> <p><b>Door section height:</b> <input type="checkbox"/> 625    <input type="checkbox"/> 750</p> <p><b>Glazing position:</b> (only in centre with Micrograin) <input type="checkbox"/> 1    <input type="checkbox"/> 2</p>	09.07.2001 – 28.02.2013	3087623	Units	
		01.02.2009 – 28.02.2013	3087657		/m <sup>2</sup>
					/m <sup>2</sup>
					+1
	<p><b>* Top door section, door section, with wicket door, without lintel seal</b></p> <p>S-ribbed, Stucco L-ribbed, Micrograin Based on RAL _____</p> <p><b>Door section height:</b> <input type="checkbox"/> 375    <input type="checkbox"/> 500 <input type="checkbox"/> 625    <input type="checkbox"/> 750</p>	09.07.2001 – 28.02.2013	3087624	Units	
		01.02.2009 – 28.02.2013	3087658		/m <sup>2</sup>
					/m <sup>2</sup>
					+1
	<p><b>* Top door section, double-skinned, with wicket door, with lintel seal</b></p> <p>S-ribbed, Stucco L-ribbed, Micrograin Based on RAL _____</p> <p><b>Door section height:</b> <input type="checkbox"/> 375    <input type="checkbox"/> 500 <input type="checkbox"/> 625    <input type="checkbox"/> 750</p>	09.07.2001 – 28.02.2013	3087702	Units	
		01.02.2009 – 28.02.2013	3087706		/m <sup>2</sup>
					/m <sup>2</sup>
					+1

+1 Surcharge for door sections in preferred colour and RAL to choose, see pages 135 – 136 / indicate RAL colour article number

+2 Surcharge for compound glazing, see page 83 – 84 / indicate the article number for the respective compound glazing

<b>ORDER</b>	Customer no.: _____	Order no./com.: _____	<b>*Please take information from the data label!</b>	
			Order no.:	Door no.:
	Customer name: _____		Product no.:	Type:
	Shipping address: _____		Year of manufacture:	
	Place/date: _____		Stamp and signature	

# 1. Double-Skinned Door Sections 42 mm

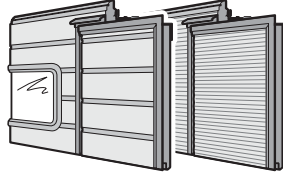
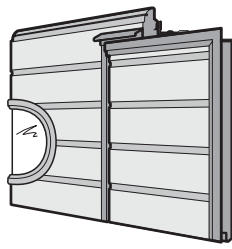
Article	Description	Production period	Art. no.	Qty.	€
	<p><b>* Top door section, double-skinned, with wicket door, with compound glazing type A, without lintel seal</b></p> <p>S-ribbed, Stucco L-ribbed, Micrograin Based on RAL _____ Compound glazing version</p> <p><b>Door section height:</b>  <input type="checkbox"/> 500    <input type="checkbox"/> 625    <input type="checkbox"/> 750</p> <p><b>Glazing position:</b> (only in centre with Micrograin)  <input type="checkbox"/> 1    <input type="checkbox"/> 2    <input type="checkbox"/> 3</p>	<p>09.07.2001 – 28.02.2013 01.02.2009 – 28.02.2013</p>	<p>3087625 3087659</p>	<p>Units</p> <p>_____ _____ _____ _____</p>	<p>/m<sup>2</sup> /m<sup>2</sup> +<sup>1</sup> +<sup>2</sup></p>
	<p><b>* Top door section, double-skinned, with wicket door, with compound glazing type A, with lintel seal</b></p> <p>S-ribbed, Stucco L-ribbed, Micrograin Based on RAL _____ Compound glazing version</p> <p><b>Door section height:</b>  <input type="checkbox"/> 500    <input type="checkbox"/> 625    <input type="checkbox"/> 750</p> <p><b>Glazing position:</b> (only in centre with Micrograin)  <input type="checkbox"/> 1    <input type="checkbox"/> 2    <input type="checkbox"/> 3</p>	<p>09.07.2001 – 28.02.2013 01.02.2009 – 28.02.2013</p>	<p>3087703 3087707</p>	<p>Units</p> <p>_____ _____ _____ _____</p>	<p>/m<sup>2</sup> /m<sup>2</sup> +<sup>1</sup> +<sup>2</sup></p>
	<p><b>* Top door section, double-skinned, ribbed, with wicket door, with compound glazing type C</b></p> <p>Based on RAL _____ Compound glazing type C</p> <p><b>Door section height:</b>  <input type="checkbox"/> 500    <input type="checkbox"/> 625    <input type="checkbox"/> 750</p> <p><b>Glazing position:</b>  <input type="checkbox"/> 1    <input type="checkbox"/> 2    <input type="checkbox"/> 3</p>	<p>09.07.2001 – 31.01.2009</p>	<p>3087598 3047150</p>	<p>Units</p> <p>_____ _____ _____</p>	<p>/m<sup>2</sup> +<sup>1</sup> /each</p>

+<sup>1</sup> Surcharge for door sections in preferred colour and RAL to choose, see pages 135 – 136 / indicate RAL colour article number

+<sup>2</sup> Surcharge for compound glazing, see page 83 – 84 / indicate the article number for the respective compound glazing

<b>ORDER</b>	Customer no.: _____	Order no./com.: _____	<b>*Please take information from the data label!</b>	
			Order no.:	Door no.:
	Customer name: _____		Product no.:	Type:
	Shipping address: _____		Year of manufacture:	
	Place/date: _____		Stamp and signature	

# 1. Double-Skinned Door Sections 42 mm

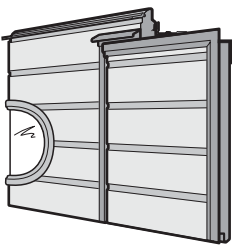
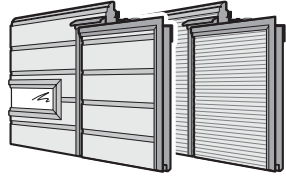
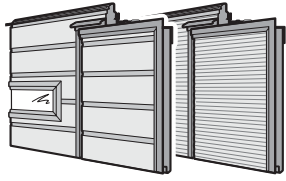
Article	Description	Production period	Art. no.	Qty.	€
	<p><b>* Top door section, double-skinned, ribbed, with wicket door, with compound glazing type C, with lintel seal</b></p> <p>Based on RAL _____ Compound glazing type C</p> <p><b>Door section height:</b>  <input type="checkbox"/> 500    <input type="checkbox"/> 625    <input type="checkbox"/> 750</p> <p><b>Glazing position:</b>  <input type="checkbox"/> 1    <input type="checkbox"/> 2    <input type="checkbox"/> 3</p>	09.07.2001 – 31.01.2009	3087701	Units	/m <sup>2</sup> +1 /each
			3047150		
	<p><b>* Top door section, double-skinned, with wicket door, with compound glazing type D</b></p> <p>S-ribbed, Stucco L-ribbed, Micrograin Based on RAL _____ Compound glazing version</p> <p><b>Door section height:</b>  <input type="checkbox"/> 500    <input type="checkbox"/> 625    <input type="checkbox"/> 750</p> <p><b>Glazing position:</b> (only in centre with Micrograin)  <input type="checkbox"/> 1    <input type="checkbox"/> 2    <input type="checkbox"/> 3</p>	09.07.2001 – 28.02.2013 01.02.2009 – 28.02.2013	3087626 3087660	Units	/m <sup>2</sup> /m <sup>2</sup> +1 +2
	<p><b>* Top door section, double-skinned, with wicket door, with compound glazing type D, with lintel seal</b></p> <p>S-ribbed, Stucco L-ribbed, Micrograin Based on RAL _____ Compound glazing version</p> <p><b>Door section height:</b>  <input type="checkbox"/> 500    <input type="checkbox"/> 625    <input type="checkbox"/> 750</p> <p><b>Glazing position:</b> (only in centre with Micrograin)  <input type="checkbox"/> 1    <input type="checkbox"/> 2    <input type="checkbox"/> 3</p>	09.07.2001 – 28.02.2013 01.02.2009 – 28.02.2013	3087704 3087708	Units	/m <sup>2</sup> /m <sup>2</sup> +1 +2

+1 Surcharge for door sections in preferred colour and RAL to choose, see pages 135 – 136 / indicate RAL colour article number  
+2 Surcharge for compound glazing, see page 83 – 84 / indicate the article number for the respective compound glazing

<b>ORDER</b>	Customer no.: _____	Order no./com.: _____	<b>*Please take information from the data label!</b>	
	Customer name: _____	Shipping address: _____	Order no.: _____	Door no.: _____
	Place/date: _____	Stamp and signature _____	Product no.: _____	Type: _____
			Year of manufacture: _____	

# 1. Double-Skinned Door Sections 42 mm

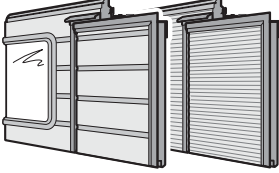
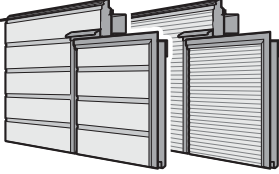
Article	Description	Production period	Art. no.	Qty.	€
	<p><b>* Top door section, double-skinned, with wicket door, with compound glazing type E</b></p> <p>S-ribbed, Stucco L-ribbed, Micrograin Based on RAL _____ Compound glazing version</p> <p><b>Door section height:</b> <input type="checkbox"/> 625    <input type="checkbox"/> 750</p> <p><b>Glazing position:</b> (only in centre with Micrograin) <input type="checkbox"/> 1    <input type="checkbox"/> 2</p>	<p>09.07.2001 – 28.02.2013 01.02.2009 – 28.02.2013</p>	<p>3087627 3087661</p>	<p>Units</p> <p>_____ _____ _____ _____</p>	<p>/m<sup>2</sup> /m<sup>2</sup> +<sup>1</sup> +<sup>2</sup></p>
	<p><b>* Top door section, double-skinned, with wicket door, with compound glazing type E, with lintel seal</b></p> <p>S-ribbed, Stucco L-ribbed, Micrograin Based on RAL _____ Compound glazing version</p> <p><b>Door section height:</b> <input type="checkbox"/> 625    <input type="checkbox"/> 750</p> <p><b>Glazing position:</b> (only in centre with Micrograin) <input type="checkbox"/> 1    <input type="checkbox"/> 2</p>	<p>09.07.2001 – 28.02.2013 01.02.2009 – 28.02.2013</p>	<p>3087705 3087709</p>	<p>Units</p> <p>_____ _____ _____ _____</p>	<p>/m<sup>2</sup> /m<sup>2</sup> +<sup>1</sup> +<sup>2</sup></p>
	<p><b>* Top door section, double-skinned, with wicket door with trip-free threshold, with lintel seal</b></p> <p><b>Up to door widths of 5500 mm:</b> S-ribbed, Stucco L-ribbed, Micrograin</p> <p><b>From door widths of 5510 mm:</b> S-ribbed, Stucco L-ribbed, Micrograin</p> <p><b>Door section height:</b> <input type="checkbox"/> 375    <input type="checkbox"/> 500 <input type="checkbox"/> 625    <input type="checkbox"/> 750</p> <p>Based on RAL _____</p>	<p>01.05.2005 – 28.02.2013 01.02.2009 – 28.02.2013</p>	<p>3087628 3087662</p>	<p>Units</p> <p>_____ _____ _____ _____</p>	<p>/m<sup>2</sup> /m<sup>2</sup>  /m<sup>2</sup> /m<sup>2</sup>  +<sup>1</sup></p>
	<p>S-ribbed, Stucco L-ribbed, Micrograin</p> <p>02.11.2005 – 28.02.2013 01.02.2009 – 28.02.2013</p> <p>3087629 3087663</p>	<p>_____ _____</p>	<p>_____ _____</p>	<p>_____ _____</p>	

+<sup>1</sup> Surcharge for door sections in preferred colour and RAL to choose, see pages 135 – 136/indicate RAL colour article number

+<sup>2</sup> Surcharge for compound glazing, see page 83 – 84/indicate the article number for the respective compound glazing

<b>ORDER</b>	Customer no.: _____	Order no./com.: _____	<b>*Please take information from the data label!</b>	
			Order no.:	Door no.:
	Customer name: _____		Product no.:	Type:
	Shipping address: _____		Year of manufacture:	
	Place/date: _____		Stamp and signature	

# 1. Double-Skinned Door Sections 42 mm

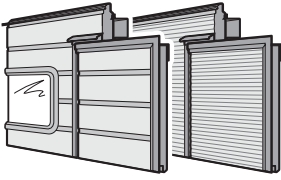
Article	Description	Production period	Art. no.	Qty.	€
	<p><b>* Top door section, double-skinned, with wicket door with trip-free threshold, with compound glazing type A, with lintel seal</b></p> <p>S-ribbed, Stucco L-ribbed, Micrograin Based on RAL _____ Compound glazing version</p> <p><b>Door section height:</b> <input type="checkbox"/> 625    <input type="checkbox"/> 750</p> <p><b>Glazing position:</b> (only in centre with Micrograin) <input type="checkbox"/> 1    <input type="checkbox"/> 2</p>	<p>01.05.2005 – 28.02.2013 01.02.2009 – 28.02.2013</p>	<p>3087630 3087664</p>	<p>Units</p> <p>_____ _____ _____ _____</p>	<p>/m<sup>2</sup> /m<sup>2</sup> +<sup>1</sup> +<sup>2</sup></p>
	<p><b>* Top door section, double-skinned, ribbed, with wicket door with trip-free threshold, with compound glazing type C, with lintel seal</b></p> <p>Based on RAL _____ Compound glazing type C</p> <p><b>Door section height:</b> <input type="checkbox"/> 625    <input type="checkbox"/> 750</p> <p><b>Glazing position:</b> <input type="checkbox"/> 1    <input type="checkbox"/> 2</p>	<p>01.05.2005 – 31.01.2009</p>	<p>3087599 3047150</p>	<p>Units</p> <p>_____ _____ _____</p>	<p>/m<sup>2</sup> +<sup>1</sup> /each</p>

+<sup>1</sup> Surcharge for door sections in preferred colour and RAL to choose, see pages 135 – 136 / indicate RAL colour article number

+<sup>2</sup> Surcharge for compound glazing, see page 83 – 84 / indicate the article number for the respective compound glazing

<b>ORDER</b>	Customer no.: _____	Order no./com.: _____	<b>*Please take information from the data label!</b>	
			Order no.: _____	Door no.: _____
	Customer name: _____		Product no.: _____	Type: _____
	Shipping address: _____		Year of manufacture: _____	
	Place/date: _____		Stamp and signature _____	

# 1. Double-Skinned Door Sections 42 mm

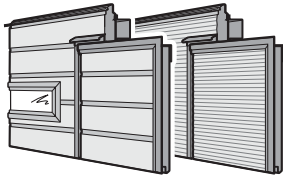
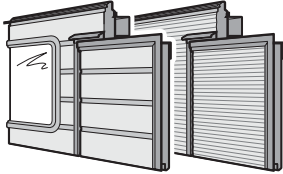
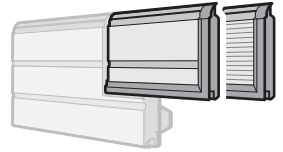
Article	Description	Production period	Art. no.	Qty.	€	
	<p><b>* Top door section, double-skinned, with wicket door with trip-free threshold, with compound glazing type D, with lintel seal</b></p> <p><b>Up to door widths of 5500 mm:</b>                      S-ribbed, Stucco                      L-ribbed, Micrograin</p> <p><b>From door widths of 5510 mm:</b>                      S-ribbed, Stucco                      L-ribbed, Micrograin                      Based on RAL _____                      Compound glazing version</p> <p><b>Door section height:</b>  <input type="checkbox"/> 500    <input type="checkbox"/> 625    <input type="checkbox"/> 750</p> <p><b>Glazing position:</b>                      (only in centre with Micrograin)  <input type="checkbox"/> 1    <input type="checkbox"/> 2</p>	01.05.2005 – 28.02.2013 01.02.2009 – 28.02.2013  02.11.2005 – 28.02.2013 01.02.2009 – 28.02.2013	3087631 3087665  3087632 3087666	Units  _____ _____  _____ _____	/m <sup>2</sup> /m <sup>2</sup>  /m <sup>2</sup> /m <sup>2</sup> + <sup>1</sup> + <sup>2</sup>	
		<p><b>* Top door section, double-skinned, with wicket door with trip-free threshold, with compound glazing type E, with lintel seal, up to door widths of 5000 mm</b></p> <p>S-ribbed, Stucco                      L-ribbed, Micrograin                      Based on RAL _____                      Compound glazing version</p> <p><b>Door section height:</b>  <input type="checkbox"/> 750</p> <p><b>Glazing position:</b>                      (only in centre with Micrograin)  <input type="checkbox"/> 1</p>	01.05.2005 – 28.02.2013 01.02.2009 – 28.02.2013	3087633 3087667	Units  _____ _____	/m <sup>2</sup> /m <sup>2</sup> + <sup>1</sup> + <sup>2</sup>
		<p><b>* Wicket door section for bottom door section, double-skinned, 375, up to door widths of 5500 mm</b></p> <p>S-ribbed, Stucco                      L-ribbed, Micrograin                      Based on RAL _____</p> <p>If hinge is required for wicket door</p>	09.07.2001 – 28.02.2013 01.02.2009 – 28.02.2013	3045408 3086421  3042410	Units  _____ _____ _____	/each /each + <sup>1</sup> /each

+<sup>1</sup> Surcharge for door sections in preferred colour and RAL to choose, see pages 135 – 136/indicate RAL colour article number

+<sup>2</sup> Surcharge for compound glazing, see page 83 – 84/indicate the article number for the respective compound glazing

<b>ORDER</b>	Customer no.: _____	Order no./com.: _____	<b>*Please take information from the data label!</b>	
			Order no.:	Door no.:
	Customer name: _____		Product no.:	Type:
	Shipping address: _____		Year of manufacture: _____	
Place/date: _____		Stamp and signature _____		

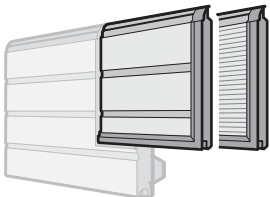
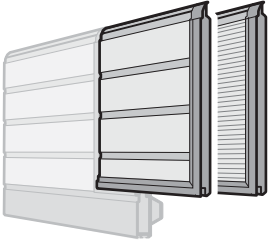
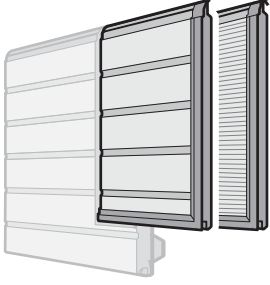
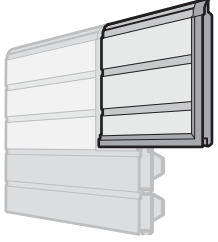

# 1. Double-Skinned Door Sections 42 mm

Article	Description	Production period	Art. no.	Qty.	€		
	<p><b>* Wicket door section for bottom door section, double-skinned, 500, up to door widths of 5500 mm</b></p> <p>S-ribbed, Stucco L-ribbed, Micrograin Based on RAL _____</p> <p>If hinge is required for wicket door</p>	<p>09.07.2001 – 28.02.2013 01.02.2009 – 28.02.2013</p>	<p>3044886 3081078 _____ 3042410</p>	<p>Units _____ _____ _____ _____</p>	<p>/each /each +<sup>1</sup> /each</p>		
		<p><b>* Wicket door section for bottom door section, double-skinned, 625, up to door widths of 5500 mm</b></p> <p>S-ribbed, Stucco L-ribbed, Micrograin Based on RAL _____</p> <p>If hinge is required for wicket door</p>	<p>09.07.2001 – 28.02.2013 01.02.2009 – 28.02.2013</p>	<p>3044887 3086422 _____ 3042410</p>	<p>Units _____ _____ _____ _____</p>	<p>/each /each +<sup>1</sup> /each</p>	
			<p><b>* Wicket door section for bottom door section, double-skinned, 750, up to door widths of 5000 mm</b></p> <p>S-ribbed, Stucco L-ribbed, Micrograin Based on RAL _____</p> <p>If hinge is required for wicket door</p>	<p>09.07.2001 – 28.02.2013 01.02.2009 – 28.02.2013</p>	<p>3056105 3086423 _____ 3042410</p>	<p>Units _____ _____ _____ _____</p>	<p>/each /each +<sup>1</sup> /each</p>
				<p><b>* Wicket door section for bottom door section, double-skinned, 625, ribbed, from door widths of 5510 mm</b></p> <p>Based on RAL _____</p> <p>If hinge is required for wicket door</p>	<p>09.07.2001 – 28.02.2013</p>	<p>3089057 _____ 3042410</p>	<p>Units _____ _____ _____</p>

+<sup>1</sup> Surcharge for door sections in preferred colour and RAL to choose, see pages 135 – 136 / indicate RAL colour article number  
+<sup>2</sup> Surcharge for compound glazing, see page 83 – 84 / indicate the article number for the respective compound glazing

<b>ORDER</b>	Customer no.: _____	Order no./com.: _____	<b>*Please take information from the data label!</b>	
			Order no.:	Door no.:
	Customer name: _____		Product no.:	Type:
	Shipping address: _____		Year of manufacture:	
	Place/date: _____		Stamp and signature	

# 1. Double-Skinned Door Sections 42 mm

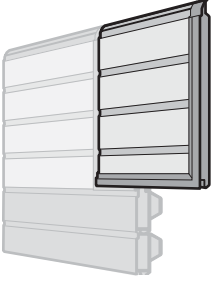
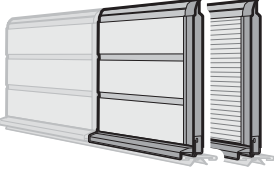
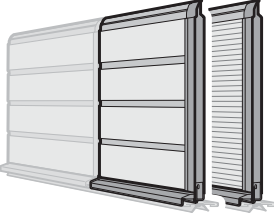
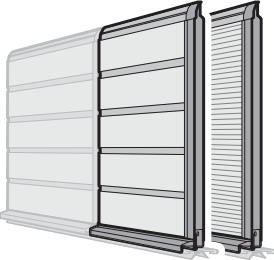

Article	Description	Production period	Art. no.	Qty.	€
	<p><b>* Wicket door section for bottom door section, double-skinned, 750, ribbed, from door widths of 5510 mm</b> Based on RAL _____</p> <p>If hinge is required for wicket door</p>	09.07.2001 – 28.02.2013	3089058	Units	/each + <sup>1</sup>
			3042410		/each
	<p><b>* Wicket door section for bottom door section, double-skinned, 375, for wicket door with trip-free threshold</b> S-ribbed, Stucco L-ribbed, Micrograin Based on RAL _____</p> <p>If hinge is required for wicket door</p>	01.05.2005 – 28.02.2013 01.02.2009 – 28.02.2013	3065044	Units	/each
			3086424		/each + <sup>1</sup>
	<p><b>* Wicket door section for bottom door section, double-skinned, 500, for wicket door with trip-free threshold</b> S-ribbed, Stucco L-ribbed, Micrograin Based on RAL _____</p> <p>If hinge is required for wicket door</p>	01.05.2005 – 28.02.2013 01.02.2009 – 28.02.2013	3065045	Units	/each
			3081080		/each + <sup>1</sup>
	<p><b>* Wicket door section for bottom door section, double-skinned, 625, for wicket door with trip-free threshold</b> S-ribbed, Stucco L-ribbed, Micrograin Based on RAL _____</p> <p>If hinge is required for wicket door</p>	01.05.2005 – 28.02.2013 01.02.2009 – 28.02.2013	3065046	Units	/each
			3086425		/each + <sup>1</sup>
			3042410		/each

+<sup>1</sup> Surcharge for door sections in preferred colour and RAL to choose, see pages 135 – 136/indicate RAL colour article number

+<sup>2</sup> Surcharge for compound glazing, see page 83 – 84/indicate the article number for the respective compound glazing

<b>ORDER</b>	Customer no.:	Order no./com.:	<b>*Please take information from the data label!</b>	
			Order no.:	Door no.:
	Customer name:		Product no.:	Type:
	Shipping address:		Year of manufacture:	
	Place/date:		Stamp and signature	

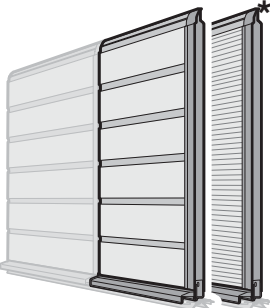
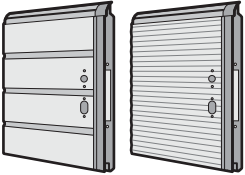
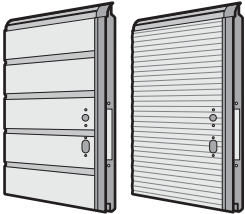
# 1. Double-Skinned Door Sections 42 mm

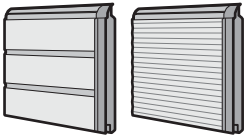
Article	Description	Production period	Art. no.	Qty.	€	
	<b>Wicket door section for bottom door section, double-skinned, 750, for wicket door with trip-free threshold</b>  S-ribbed, Stucco L-ribbed, Micrograin Based on RAL _____  If hinge is required for wicket door	01.05.2005 – 28.02.2013 01.02.2009 – 28.02.2013	3065047 3086426 _____ 3042410	Units  _____ _____ _____ _____	_____ _____ _____ _____	
					/each	
						/each
						+1
	<b>Wicket door section, double-skinned, 500, for lock</b>  S-ribbed, Stucco L-ribbed, Micrograin Based on RAL _____  If hinge is required for wicket door	09.07.2001 – 28.02.2013 01.02.2009 – 28.02.2013	3044889 3081081 _____ 3042410	Units  _____ _____ _____ _____	_____ _____ _____ _____	
					/each	
						/each
						+1
	<b>Wicket door section, double-skinned, 625, for lock</b>  S-ribbed, Stucco L-ribbed, Micrograin Based on RAL _____  If hinge is required for wicket door	09.07.2001 – 28.02.2013 01.02.2009 – 28.02.2013	3056106 3086427 _____ 3042410	Units  _____ _____ _____ _____	_____ _____ _____ _____	
					/each	
						/each
						+1
	<b>Wicket door section, double-skinned, 750, for lock</b>  S-ribbed, Stucco L-ribbed, Micrograin Based on RAL _____  If hinge is required for wicket door	09.07.2001 – 28.02.2013 01.02.2009 – 28.02.2013	3056107 3086428 _____ 3042410	Units  _____ _____ _____ _____	_____ _____ _____ _____	
					/each	
						/each
						+1
	<b>Wicket door section, double-skinned, 375</b>  S-ribbed, Stucco L-ribbed, Micrograin Based on RAL _____  If hinge is required for wicket door	09.07.2001 – 28.02.2013 01.02.2009 – 28.02.2013	3044892 3086429 _____ 3042410	Units  _____ _____ _____ _____	_____ _____ _____ _____	
					/each	
						/each
						+1

+1 Surcharge for door sections in preferred colour and RAL to choose, see pages 135 – 136 / indicate RAL colour article number

+2 Surcharge for compound glazing, see page 83 – 84 / indicate the article number for the respective compound glazing

<b>ORDER</b>	Customer no.: _____	Order no./com.: _____	<b>*Please take information from the data label!</b>	
			Order no.:	Door no.:
	Customer name: _____		Product no.:	Type:
	Shipping address: _____		Year of manufacture:	
	Place/date: _____		Stamp and signature _____	

# 1. Double-Skinned Door Sections 42 mm

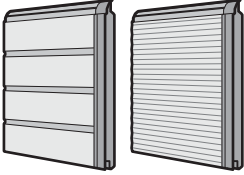
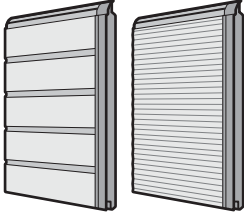
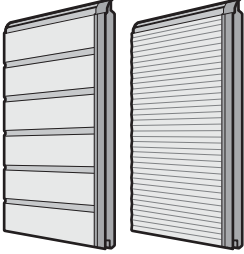
Article	Description	Production period	Art. no.	Qty.	€		
	<b>* Wicket door section, double-skinned, 500</b> S-ribbed, Stucco L-ribbed, Micrograin Based on RAL _____ If hinge is required for wicket door	09.07.2001 – 28.02.2013 01.02.2009 – 28.02.2013	3044888 3081082 _____ 3042410	Units _____ _____ _____ _____	/each /each + <sup>1</sup> /each		
		<b>* Wicket door section, double-skinned, 625</b> S-ribbed, Stucco L-ribbed, Micrograin Based on RAL _____ If hinge is required for wicket door	09.07.2001 – 28.02.2013 01.02.2009 – 28.02.2013	3056108 3086430 _____ 3042410	Units _____ _____ _____ _____	/each /each + <sup>1</sup> /each	
			<b>* Wicket door section, double-skinned, 750</b> S-ribbed, Stucco L-ribbed, Micrograin Based on RAL _____ If hinge is required for wicket door	09.07.2001 – 28.02.2013 01.02.2009 – 28.02.2013	3056109 3086431 _____ 3042410	Units _____ _____ _____ _____	/each /each + <sup>1</sup> /each
			<b>* Wicket door section, double-skinned, 500, with compound glazing type A</b> S-ribbed, Stucco L-ribbed, Micrograin Based on RAL _____ Compound glazing version If hinge is required for wicket door	09.07.2001 – 28.02.2013 01.02.2009 – 28.02.2013	3044890 3081083 _____ 3042410	Units _____ _____ _____ _____	/each /each + <sup>1</sup> + <sup>2</sup> /each

+<sup>1</sup> Surcharge for door sections in preferred colour and RAL to choose, see pages 135 – 136/indicate RAL colour article number

+<sup>2</sup> Surcharge for compound glazing, see page 83 – 84/indicate the article number for the respective compound glazing

<b>ORDER</b>	Customer no.:	Order no./com.:	<b>*Please take information from the data label!</b>	
			Order no.:	Door no.:
	Customer name:		Product no.:	Type:
	Shipping address:		Year of manufacture:	
	Place/date:		Stamp and signature	

# 1. Double-Skinned Door Sections 42 mm

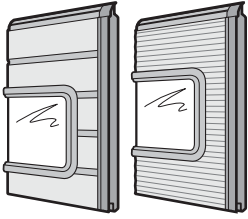
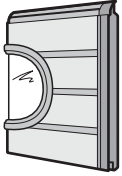
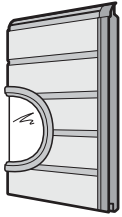
Article	Description	Production period	Art. no.	Qty.	€	
	<p><b>* Wicket door section, double-skinned, 625, with compound glazing type A</b></p> <p>S-ribbed, Stucco L-ribbed, Micrograin Based on RAL _____ Compound glazing version</p> <p><b>Glazing position:</b> (only in centre with Micrograin) <input type="checkbox"/> 1      <input type="checkbox"/> 2</p> <p>If hinge is required for wicket door</p>	<p>09.07.2001 – 28.02.2013 01.02.2009 – 28.02.2013</p>	<p>3056110 3086432 _____ _____</p>	<p>Units _____ _____ _____ _____</p>	<p>/each /each +1 +2  /each</p>	
	<p><b>* Wicket door section, double-skinned, 750, with compound glazing type A</b></p> <p>S-ribbed, Stucco L-ribbed, Micrograin Based on RAL _____ Compound glazing version</p> <p><b>Glazing position:</b> (only in centre with Micrograin) <input type="checkbox"/> 1      <input type="checkbox"/> 2      <input type="checkbox"/> 3</p> <p>If hinge is required for wicket door</p>	<p>09.07.2001 – 28.02.2013 01.02.2009 – 28.02.2013</p>	<p>3056111 3086433 _____ _____</p>	<p>Units _____ _____ _____ _____</p>	<p>/each /each +1 +2  /each</p>	
		<p><b>* Wicket door section, double-skinned, 500, ribbed, with compound glazing type C</b></p> <p>Based on RAL _____ Compound glazing type C</p> <p>If hinge is required for wicket door</p>	<p>09.07.2001 – 31.01.2009</p>	<p>3056112 3047150 3042410</p>	<p>Units _____ _____ _____</p>	<p>/each +1 /each  /each</p>
		<p><b>* Wicket door section, double-skinned, 625, ribbed, with compound glazing type C</b></p> <p>Based on RAL _____ Compound glazing type C</p> <p><b>Glazing position:</b> <input type="checkbox"/> 1      <input type="checkbox"/> 2</p> <p>If hinge is required for wicket door</p>	<p>09.07.2001 – 31.01.2009</p>	<p>3056113 3047150 3042410</p>	<p>Units _____ _____ _____</p>	<p>/each +1 /each  /each</p>

+1 Surcharge for door sections in preferred colour and RAL to choose, see pages 135 – 136 / indicate RAL colour article number

+2 Surcharge for compound glazing, see page 83 – 84 / indicate the article number for the respective compound glazing

<b>ORDER</b>	Customer no.:	Order no./com.:	<b>*Please take information from the data label!</b>	
			Order no.:	Door no.:
	Customer name:		Product no.:	Type:
	Shipping address: _____		Year of manufacture:	
	Place/date:		Stamp and signature	

# 1. Double-Skinned Door Sections 42 mm

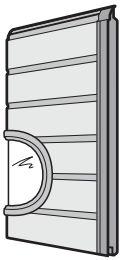
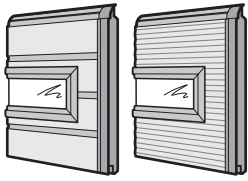
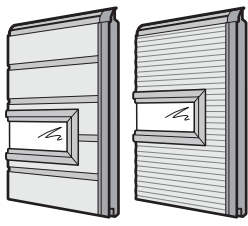
Article	Description	Production period	Art. no.	Qty.	€	
	<p><b>* Wicket door section, double-skinned, 750, ribbed, with compound glazing type C</b> Based on RAL _____ Compound glazing type C</p> <p><b>Glazing position:</b>  <input type="checkbox"/> 1      <input type="checkbox"/> 2      <input type="checkbox"/> 3</p> <p>If hinge is required for wicket door</p>	09.07.2001 – 31.01.2009	3056114	Units	/each	
			3047150		+ <sup>1</sup>	/each
			3042410			/each
	<p><b>* Wicket door section, double-skinned, 500, with compound glazing type D</b> Stucco, ribbed Micrograin Based on RAL _____ Compound glazing version</p> <p>If hinge is required for wicket door</p>	09.07.2001 – 28.02.2013 01.02.2009 – 28.02.2013	3056115	Units	/each	
			3081084		+ <sup>1</sup>	/each
			3042410		+ <sup>2</sup>	/each
	<p><b>* Wicket door section, double-skinned, 625, with compound glazing type D</b> S-ribbed, Stucco L-ribbed, Micrograin Based on RAL _____ Compound glazing version</p> <p><b>Glazing position:</b> (only in centre with Micrograin)  <input type="checkbox"/> 1      <input type="checkbox"/> 2</p> <p>If hinge is required for wicket door</p>	09.07.2001 – 28.02.2013 01.02.2009 – 28.02.2013	3056116	Units	/each	
			3086434		+ <sup>1</sup>	/each
			3042410		+ <sup>2</sup>	/each

+<sup>1</sup> Surcharge for door sections in preferred colour and RAL to choose, see pages 135 – 136/indicate RAL colour article number

+<sup>2</sup> Surcharge for compound glazing, see page 83 – 84/indicate the article number for the respective compound glazing

<b>ORDER</b>	Customer no.:	Order no./com.:	<b>*Please take information from the data label!</b>	
			Order no.:	Door no.:
	Customer name:		Product no.:	Type:
	Shipping address:		Year of manufacture:	
	Place/date:		Stamp and signature	

# 1. Double-Skinned Door Sections 42 mm

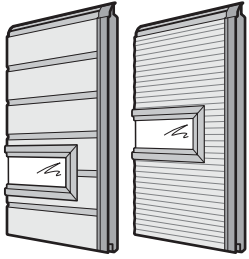
Article	Description	Production period	Art. no.	Qty.	€
	<p><b>* Wicket door section, double-skinned, 750, with compound glazing type D</b></p> <p>S-ribbed, Stucco L-ribbed, Micrograin Based on RAL _____ Compound glazing version</p> <p><b>Glazing position:</b> (only in centre with Micrograin) <input type="checkbox"/> 1    <input type="checkbox"/> 2    <input type="checkbox"/> 3</p> <p>If hinge is required for wicket door</p>	<p>09.07.2001 – 28.02.2013 01.02.2009 – 28.02.2013</p>	<p>3056117 3086435 _____ _____</p>	<p>Units _____ _____ _____ _____</p>	<p>/each /each +1 +2  /each</p>
	<p><b>* Wicket door section, double-skinned, 625, with compound glazing type E</b></p> <p>S-ribbed, Stucco L-ribbed, Micrograin Based on RAL _____ Compound glazing version</p> <p>If hinge is required for wicket door</p>	<p>09.07.2001 – 28.02.2013 01.02.2009 – 28.02.2013</p>	<p>3056118 3086436 _____ _____</p>	<p>Units _____ _____ _____ _____</p>	<p>/each /each +1 +2  /each</p>
	<p><b>* Wicket door section, double-skinned, 750, with compound glazing type E</b></p> <p>S-ribbed, Stucco L-ribbed, Micrograin Based on RAL _____ Compound glazing version</p> <p><b>Glazing position:</b> (only in centre with Micrograin) <input type="checkbox"/> 1    <input type="checkbox"/> 2</p> <p>If hinge is required for wicket door</p>	<p>09.07.2001 – 28.02.2013 01.02.2009 – 28.02.2013</p>	<p>3056119 3086437 _____ _____</p>	<p>Units _____ _____ _____ _____</p>	<p>/each /each +1 +2  /each</p>
	<p><b>* Top wicket door section, double-skinned, 375</b></p> <p>S-ribbed, Stucco L-ribbed, Micrograin Based on RAL _____</p> <p>If hinge is required for wicket door</p>	<p>09.07.2001 – 28.02.2013 01.02.2009 – 28.02.2013</p>	<p>3044897 3086438 _____ 3042410</p>	<p>Units _____ _____ _____ _____</p>	<p>/each /each +1  /each</p>

+1 Surcharge for door sections in preferred colour and RAL to choose, see pages 135 – 136 / indicate RAL colour article number

+2 Surcharge for compound glazing, see page 83 – 84 / indicate the article number for the respective compound glazing

<b>ORDER</b>	Customer no.: _____	Order no./com.: _____	<b>*Please take information from the data label!</b>	
			Order no.:	Door no.:
	Customer name: _____		Product no.:	Type:
	Shipping address: _____		Year of manufacture:	
	Place/date: _____		Stamp and signature _____	

# 1. Double-Skinned Door Sections 42 mm

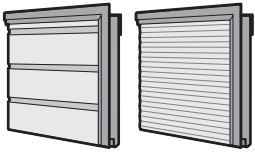
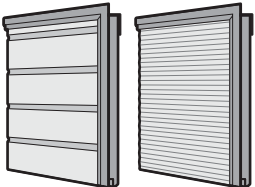
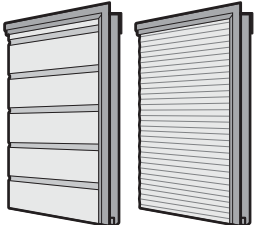
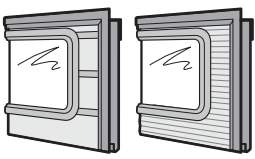
Article	Description	Production period	Art. no.	Qty.	€		
	<p><b>* Top wicket door section, double-skinned, 500</b></p> <p>S-ribbed, Stucco L-ribbed, Micrograin Based on RAL _____</p> <p>If hinge is required for wicket door</p>	<p>09.07.2001 – 28.02.2013 01.02.2009 – 28.02.2013</p>	<p>3044894 3081085 _____ 3042410</p>	<p>Units _____ _____ _____ _____</p>	<p><b>/each</b> <b>/each</b> <b>+<sup>1</sup></b> <b>/each</b></p>		
		<p><b>* Top wicket door section, double-skinned, 625</b></p> <p>S-ribbed, Stucco L-ribbed, Micrograin Based on RAL _____</p> <p>If hinge is required for wicket door</p>	<p>09.07.2001 – 28.02.2013 01.02.2009 – 28.02.2013</p>	<p>3056120 3086439 _____ 3042410</p>	<p>Units _____ _____ _____ _____</p>	<p><b>/each</b> <b>/each</b> <b>+<sup>1</sup></b> <b>/each</b></p>	
			<p><b>* Top wicket door section, double-skinned, 750</b></p> <p>S-ribbed, Stucco L-ribbed, Micrograin Based on RAL _____</p> <p>If hinge is required for wicket door</p>	<p>09.07.2001 – 28.02.2013 01.02.2009 – 28.02.2013</p>	<p>3056121 3086440 _____ 3042410</p>	<p>Units _____ _____ _____ _____</p>	<p><b>/each</b> <b>/each</b> <b>+<sup>1</sup></b> <b>/each</b></p>
				<p><b>* Top wicket door section, double-skinned, 500, with compound glazing type A</b></p> <p>S-ribbed, Stucco L-ribbed, Micrograin Based on RAL _____ Compound glazing version</p> <p>If hinge is required for wicket door</p>	<p>09.07.2001 – 28.02.2013 01.02.2009 – 28.02.2013</p>	<p>3044895 3081086 _____ _____ 3042410</p>	<p>Units _____ _____ _____ _____</p>

+<sup>1</sup> Surcharge for door sections in preferred colour and RAL to choose, see pages 135 – 136/indicate RAL colour article number

+<sup>2</sup> Surcharge for compound glazing, see page 83 – 84/indicate the article number for the respective compound glazing

<b>ORDER</b>	Customer no.: _____	Order no./com.: _____	<b>*Please take information from the data label!</b>	
			Order no.:	Door no.:
	Customer name: _____		Product no.:	Type:
	Shipping address: _____		Year of manufacture:	
	Place/date: _____		Stamp and signature	

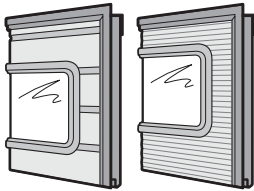
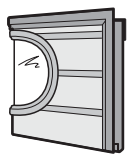
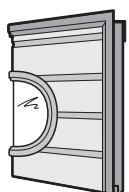

# 1. Double-Skinned Door Sections 42 mm

Article	Description	Production period	Art. no.	Qty.	€	
	<p><b>* Top wicket door section, double-skinned, 625, with compound glazing type A</b></p> <p>S-ribbed, Stucco L-ribbed, Micrograin Based on RAL _____ Compound glazing version</p> <p><b>Glazing position:</b> (only in centre with Micrograin) <input type="checkbox"/> 1      <input type="checkbox"/> 2</p> <p>If hinge is required for wicket door</p>	<p>09.07.2001 – 28.02.2013 01.02.2009 – 28.02.2013</p>	<p>3056122 3086441 _____ _____</p>	<p>Units _____ _____ _____ _____</p>	<p>/each /each +1 +2  /each</p>	
	<p><b>* Top wicket door section, double-skinned, 750, with compound glazing type A</b></p> <p>S-ribbed, Stucco L-ribbed, Micrograin Based on RAL _____ Compound glazing version</p> <p><b>Glazing position:</b> (only in centre with Micrograin) <input type="checkbox"/> 1      <input type="checkbox"/> 2      <input type="checkbox"/> 3</p> <p>If hinge is required for wicket door</p>	<p>09.07.2001 – 28.02.2013 01.02.2009 – 28.02.2013</p>	<p>3056123 3086442 _____ _____</p>	<p>Units _____ _____ _____ _____</p>	<p>/each /each +1 +2  /each</p>	
		<p><b>* Top wicket door section, double-skinned, 500, ribbed, with compound glazing type C</b></p> <p>Based on RAL _____ Compound glazing type C</p> <p>If hinge is required for wicket door</p>	<p>09.07.2001 – 31.01.2009</p>	<p>3056124 3047150 3042410</p>	<p>Units _____ _____ _____</p>	<p>/each +1 /each  /each</p>
		<p><b>* Top wicket door section, double-skinned, 625, ribbed, with compound glazing type C</b></p> <p>Based on RAL _____ Compound glazing type C</p> <p><b>Glazing position:</b> <input type="checkbox"/> 1      <input type="checkbox"/> 2</p> <p>If hinge is required for wicket door</p>	<p>09.07.2001 – 31.01.2009</p>	<p>3056125 3047150 3042410</p>	<p>Units _____ _____ _____</p>	<p>/each +1 /each  /each</p>

+1 Surcharge for door sections in preferred colour and RAL to choose, see pages 135 – 136 / indicate RAL colour article number

+2 Surcharge for compound glazing, see page 83 – 84 / indicate the article number for the respective compound glazing

<b>ORDER</b>	Customer no.:	Order no./com.:	<b>*Please take information from the data label!</b>	
			Order no.:	Door no.:
	Customer name:		Product no.:	Type:
	Shipping address: _____		Year of manufacture:	
	Place/date:		Stamp and signature	

# 1. Double-Skinned Door Sections 42 mm

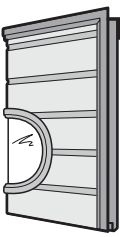
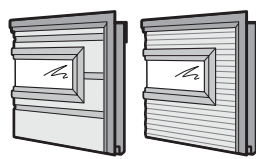
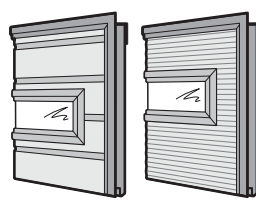
Article	Description	Production period	Art. no.	Qty.	€	
	<p><b>* Top wicket door section, double-skinned, 750, ribbed, with compound glazing type C</b> Based on RAL _____ Compound glazing type C</p> <p><b>Glazing position:</b>  <input type="checkbox"/> 1      <input type="checkbox"/> 2      <input type="checkbox"/> 3</p> <p>If hinge is required for wicket door</p>	09.07.2001 – 31.01.2009	3056126	Units	/each	
			3047150		+ <sup>1</sup>	/each
			3042410			/each
	<p><b>* Top wicket door section, double-skinned, 500, with compound glazing type D</b></p> <p>S-ribbed, Stucco L-ribbed, Micrograin Based on RAL _____ Compound glazing version</p> <p>If hinge is required for wicket door</p>	09.07.2001 – 28.02.2013 01.02.2009 – 28.02.2013	3056127 3081087	Units	/each /each + <sup>1</sup> + <sup>2</sup>	
		3042410			/each	
	<p><b>* Top wicket door section, double-skinned, 625, with compound glazing type D</b></p> <p>S-ribbed, Stucco L-ribbed, Micrograin Based on RAL _____ Compound glazing version</p> <p><b>Glazing position:</b> (only in centre with Micrograin)  <input type="checkbox"/> 1      <input type="checkbox"/> 2</p> <p>If hinge is required for wicket door</p>	09.07.2001 – 28.02.2013 01.02.2009 – 28.02.2013	3056128 3086443	Units	/each /each + <sup>1</sup> + <sup>2</sup>	
		3042410			/each	

+<sup>1</sup> Surcharge for door sections in preferred colour and RAL to choose, see pages 135 – 136/indicate RAL colour article number

+<sup>2</sup> Surcharge for compound glazing, see page 83 – 84/indicate the article number for the respective compound glazing

<b>ORDER</b>	Customer no.:	Order no./com.:	<b>*Please take information from the data label!</b>	
			Order no.:	Door no.:
	Customer name:		Product no.:	Type:
	Shipping address:		Year of manufacture:	
	Place/date:		Stamp and signature	

# 1. Double-Skinned Door Sections 42 mm

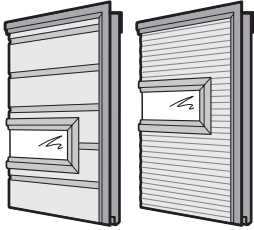
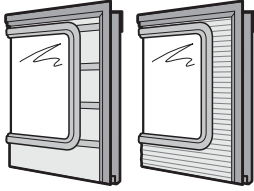
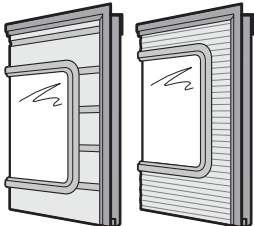
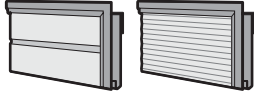
Article	Description	Production period	Art. no.	Qty.	€		
	<p><b>* Top wicket door section, double-skinned, 750, with compound glazing type D</b></p> <p>S-ribbed, Stucco L-ribbed, Micrograin Based on RAL _____ Compound glazing version</p> <p><b>Glazing position:</b> (only in centre with Micrograin) <input type="checkbox"/> 1    <input type="checkbox"/> 2    <input type="checkbox"/> 3</p> <p>If hinge is required for wicket door</p>	<p>09.07.2001 – 28.02.2013 01.02.2009 – 28.02.2013</p>	<p>3056129 3086444 _____ _____</p>	<p>Units _____ _____ _____ _____</p>	<p>/each /each +1 +2      /each</p>		
		<p><b>* Top wicket door section, double-skinned, 625, with compound glazing type E</b></p> <p>S-ribbed, Stucco L-ribbed, Micrograin Based on RAL _____ Compound glazing version</p> <p>If hinge is required for wicket door</p>	<p>09.07.2001 – 28.02.2013 01.02.2009 – 28.02.2013</p>	<p>3056130 3086445 _____ _____</p>	<p>Units _____ _____ _____ _____</p>	<p>/each /each +1 +2      /each</p>	
			<p><b>* Top wicket door section, double-skinned, 750, with compound glazing type E</b></p> <p>S-ribbed, Stucco L-ribbed, Micrograin Based on RAL _____ Compound glazing version</p> <p><b>Glazing position:</b> (only in centre with Micrograin) <input type="checkbox"/> 1    <input type="checkbox"/> 2</p> <p>If hinge is required for wicket door</p>	<p>09.07.2001 – 28.02.2013 01.02.2009 – 28.02.2013</p>	<p>3056131 3086446 _____ _____</p>	<p>Units _____ _____ _____ _____</p>	<p>/each /each +1 +2      /each</p>
				<p><b>* Top wicket door section, double-skinned, 375, for wicket door with trip-free threshold</b></p> <p>S-ribbed, Stucco L-ribbed, Micrograin Based on RAL _____</p> <p>If hinge is required for wicket door</p>	<p>01.05.2005 – 28.02.2013 01.02.2009 – 28.02.2013</p>	<p>3065048 3086447 _____ _____</p>	<p>Units _____ _____ _____ _____</p>

+1 Surcharge for door sections in preferred colour and RAL to choose, see pages 135 – 136 / indicate RAL colour article number  
+2 Surcharge for compound glazing, see page 83 – 84 / indicate the article number for the respective compound glazing

<b>ORDER</b>	Customer no.: _____	Order no./com.: _____	<b>*Please take information from the data label!</b>	
			Order no.:	Door no.:
	Customer name: _____		Product no.:	Type:
	Shipping address: _____		Year of manufacture:	
	Place/date: _____		Stamp and signature	

# 1. Double-Skinned Door Sections 42 mm

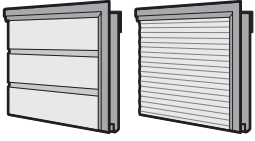
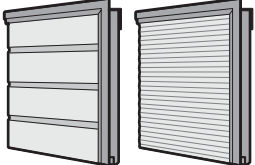
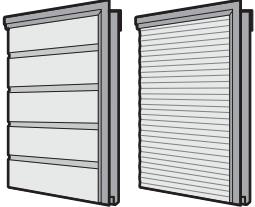
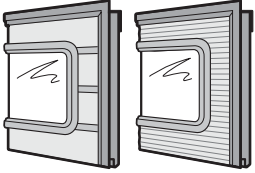
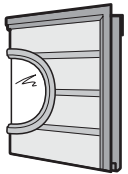
Article	Description	Production period	Art. no.	Qty.	€		
	<p><b>* Top wicket door section, double-skinned, 500, for wicket door with trip-free threshold</b></p> <p>S-ribbed, Stucco L-ribbed, Micrograin Based on RAL _____</p> <p>If hinge is required for wicket door</p>	<p>01.05.2005 – 28.02.2013 01.02.2009 – 28.02.2013</p>	<p>3065049 3081088 _____ 3042410</p>	<p>Units _____ _____ _____ _____</p>	<p>/each /each +<sup>1</sup> /each</p>		
		<p><b>* Top wicket door section, double-skinned, 625, for wicket door with trip-free threshold</b></p> <p>S-ribbed, Stucco L-ribbed, Micrograin Based on RAL _____</p> <p>If hinge is required for wicket door</p>	<p>01.05.2005 – 28.02.2013 01.02.2009 – 28.02.2013</p>	<p>3065050 3086448 _____ 3042410</p>	<p>Units _____ _____ _____ _____</p>	<p>/each /each +<sup>1</sup> /each</p>	
			<p><b>* Top wicket door section, double-skinned, 750, for wicket door with trip-free threshold</b></p> <p>S-ribbed, Stucco L-ribbed, Micrograin Based on RAL _____</p> <p>If hinge is required for wicket door</p>	<p>01.05.2005 – 28.02.2013 01.02.2009 – 28.02.2013</p>	<p>3065051 3086449 _____ 3042410</p>	<p>Units _____ _____ _____ _____</p>	<p>/each /each +<sup>1</sup> /each</p>
				<p><b>* Top wicket door section, double-skinned, 625, for wicket door with trip-free threshold, with compound glazing type A</b></p> <p>S-ribbed, Stucco L-ribbed, Micrograin Based on RAL _____ Compound glazing version</p> <p>If hinge is required for wicket door</p>	<p>01.05.2005 – 28.02.2013 01.02.2009 – 28.02.2013</p>	<p>3065052 3086450 _____ 3042410</p>	<p>Units _____ _____ _____ _____</p>
				<p><b>* Top wicket door section, double-skinned, 625, ribbed, for wicket door with trip-free threshold, with compound glazing type C</b></p> <p>Based on RAL _____ Compound glazing type C</p> <p>If hinge is required for wicket door</p>	<p>01.05.2005 – 31.01.2009</p>	<p>3065053 _____ 3047150 3042410</p>	<p>Units _____ _____ _____ _____</p>

+<sup>1</sup> Surcharge for door sections in preferred colour and RAL to choose, see pages 135 – 136 / indicate RAL colour article number

+<sup>2</sup> Surcharge for compound glazing, see page 83 – 84 / indicate the article number for the respective compound glazing

<b>ORDER</b>	Customer no.: _____	Order no./com.: _____	<b>*Please take information from the data label!</b>	
			Order no.:	Door no.:
	Customer name: _____		Product no.:	Type:
	Shipping address: _____		Year of manufacture:	
	Place/date: _____		Stamp and signature	

# 1. Double-Skinned Door Sections 42 mm

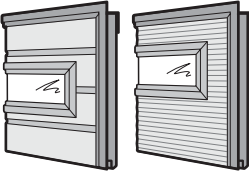
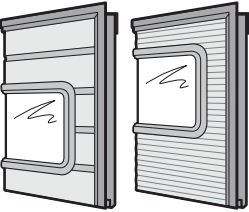
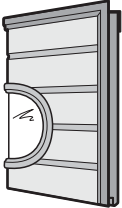
Article	Description	Production period	Art. no.	Qty.	€		
	<p><b>* Top wicket door section, double-skinned, 625, for wicket door with trip-free threshold, with compound glazing type D</b></p> <p>S-ribbed, Stucco L-ribbed, Micrograin Based on RAL _____ Compound glazing version</p> <p>If hinge is required for wicket door</p>	<p>01.05.2005 – 28.02.2013 01.02.2009 – 28.02.2013</p>	<p>3065054 3086451 _____ _____ 3042410</p>	<p>Units _____ _____ _____ _____ _____</p>	<p>/each /each +<sup>1</sup> +<sup>2</sup> /each</p>		
		<p><b>* Top wicket door section, double-skinned, 750, for wicket door with trip-free threshold, with compound glazing type A</b></p> <p>S-ribbed, Stucco L-ribbed, Micrograin Based on RAL _____ Compound glazing version</p> <p><b>Glazing position:</b> (only in centre with Micrograin) <input type="checkbox"/> 1      <input type="checkbox"/> 2</p> <p>If hinge is required for wicket door</p>	<p>01.05.2005 – 28.02.2013 01.02.2009 – 28.02.2013</p>	<p>3065055 3086452 _____ _____</p>	<p>Units _____ _____ _____ _____</p>	<p>/each /each +<sup>1</sup> +<sup>2</sup> /each</p>	
			<p><b>* Top wicket door section, double-skinned, 750, ribbed, for wicket door with trip-free threshold, with compound glazing type C</b></p> <p>Based on RAL _____ Compound glazing type C</p> <p><b>Glazing position:</b> <input type="checkbox"/> 1      <input type="checkbox"/> 2</p> <p>If hinge is required for wicket door</p>	<p>01.05.2005 – 31.01.2009</p>	<p>3065056 3047150 _____ _____</p>	<p>Units _____ _____ _____</p>	<p>/each +<sup>1</sup> /each /each</p>
			<p>_____</p>	<p>_____</p>	<p>_____</p>	<p>_____</p>	<p>/each</p>
<p>_____</p>			<p>_____</p>	<p>_____</p>	<p>_____</p>	<p>/each</p>	

+<sup>1</sup> Surcharge for door sections in preferred colour and RAL to choose, see pages 135 – 136 / indicate RAL colour article number  
+<sup>2</sup> Surcharge for compound glazing, see page 83 – 84 / indicate the article number for the respective compound glazing

<b>ORDER</b>	Customer no.: _____	Order no./com.: _____	<b>*Please take information from the data label!</b>	
			Order no.: _____	Door no.: _____
	Customer name: _____		Product no.: _____	Type: _____
	Shipping address: _____		Year of manufacture: _____	
	Place/date: _____		Stamp and signature _____	

# 1. Double-Skinned Door Sections 42 mm

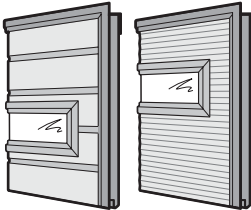
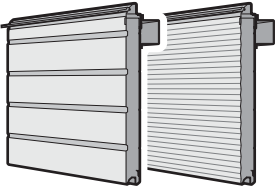
Article	Description	Production period	Art. no.	Qty.	€	
	<p><b>* Top wicket door section, double-skinned, 750, for wicket door with trip-free threshold, with compound glazing type D</b></p> <p>S-ribbed, Stucco L-ribbed, Micrograin Based on RAL _____ Compound glazing version</p> <p><b>Glazing position:</b> <input type="checkbox"/> 1      <input type="checkbox"/> 2</p> <p>If hinge is required for wicket door</p>	01.05.2005 – 28.02.2013 01.02.2009 – 28.02.2013	3065057 3086453 _____ _____	Units _____ _____ _____ _____	 /each /each + <sup>1</sup> + <sup>2</sup>  /each	
	<p><b>* Top wicket door section, double-skinned, 750, for wicket door with trip-free threshold, with compound glazing type E</b></p> <p>S-ribbed, Stucco L-ribbed, Micrograin Based on RAL _____ Compound glazing version</p>	01.05.2005 – 28.02.2013 01.02.2009 – 28.02.2013	3065058 3086454 _____ _____	Units _____ _____ _____ _____	 /each /each + <sup>1</sup> + <sup>2</sup>	
		<p><b>* Top door section, double-skinned, for intermediate height, above the wicket door with trip-free threshold, from door widths of 4010 mm, with lintel seal</b></p> <p><b>Up to door widths of 5500 mm:</b> S-ribbed, Stucco L-ribbed, Micrograin</p> <p><b>From door widths of 5510 mm:</b> S-ribbed, Stucco L-ribbed, Micrograin Based on RAL _____</p> <p><b>Door section height</b> _____</p>	01.05.2005 – 28.02.2013 01.02.2009 – 28.02.2013	3065180 3081089 _____ _____	Units _____ _____ _____ _____	 /m <sup>2</sup> /m <sup>2</sup>  /m <sup>2</sup> /m <sup>2</sup> + <sup>1</sup>
		<p>02.11.2005 – 28.02.2013 01.02.2009 – 28.02.2013</p> <p>3072867 3081090 _____ _____</p>	_____ _____ _____ _____	    	    	

+<sup>1</sup> Surcharge for door sections in preferred colour and RAL to choose, see pages 135 – 136/indicate RAL colour article number

+<sup>2</sup> Surcharge for compound glazing, see page 83 – 84/indicate the article number for the respective compound glazing

<b>ORDER</b>	Customer no.: _____	Order no./com.: _____	<b>*Please take information from the data label!</b>	
			Order no.:	Door no.:
	Customer name: _____		Product no.:	Type:
	Shipping address: _____		Year of manufacture:	
	Place/date: _____		Stamp and signature	

# 1. Double-Skinned Door Sections 42 mm

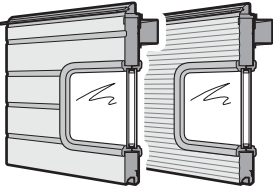
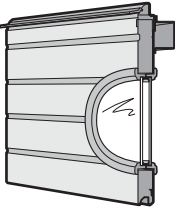
Article	Description	Production period	Art. no.	Qty.	€
	<p><b>*</b> <b>Top door section, double-skinned, for intermediate height, with compound glazing type A, above the wicket door with trip-free threshold, from door widths of 4010 mm, with lintel seal</b></p> <p>S-ribbed, Stucco L-ribbed, Micrograin Based on RAL _____ Compound glazing version</p> <p><b>Door section height</b> _____</p> <p><b>Glazing position:</b> (only in centre with Micrograin) <input type="checkbox"/> 1      <input type="checkbox"/> 2</p>	01.05.2005 – 28.02.2013	3065181	Units	   /m <sup>2</sup> /m <sup>2</sup> + <sup>1</sup> + <sup>2</sup>
		01.02.2009 – 28.02.2013	3081091	_____	
			_____	_____	
			_____	_____	
	<p><b>*</b> <b>Top door section, double-skinned, ribbed, for intermediate height, with compound glazing type C, above the wicket door with trip-free threshold, from door widths of 4010 mm, with lintel seal</b></p> <p>Based on RAL _____ Compound glazing type C</p> <p><b>Door section height</b> _____</p> <p><b>Glazing position:</b> <input type="checkbox"/> 1      <input type="checkbox"/> 2</p>	01.05.2005 – 31.01.2009	3065182  3047150	Units	   /m <sup>2</sup> + <sup>1</sup> /each
				_____	

+<sup>1</sup> Surcharge for door sections in preferred colour and RAL to choose, see pages 135 – 136 / indicate RAL colour article number  
 +<sup>2</sup> Surcharge for compound glazing, see page 83 – 84 / indicate the article number for the respective compound glazing

<b>ORDER</b>	Customer no.: _____	Order no./com.: _____	<b>*Please take information from the data label!</b>	
			Order no.:	Door no.:
	Customer name: _____		Product no.:	Type:
	Shipping address: _____		Year of manufacture:	
	Place/date: _____		Stamp and signature	

# 1. Double-Skinned Door Sections 42 mm

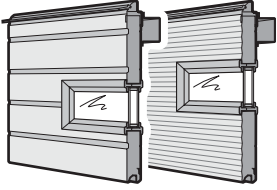
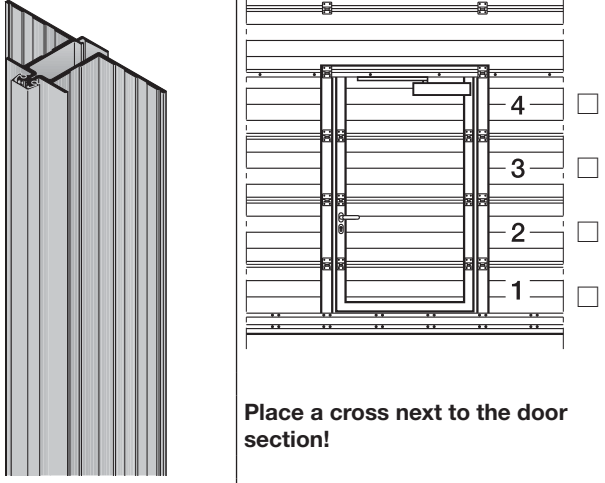
Article	Description	Production period	Art. no.	Qty.	€	
	<p><b>* Top door section, double-skinned, for intermediate height, with compound glazing type D, above the wicket door with trip-free threshold, with lintel seal</b></p> <p><b>Up to door widths 4010 to 5500 mm:</b>            S-ribbed, Stucco            L-ribbed, Micrograin</p> <p><b>From door widths of 5510 mm:</b>            S-ribbed, Stucco            L-ribbed, Micrograin            Based on RAL _____            Compound glazing version</p> <p><b>Door section height _____</b></p> <p><b>Glazing position:</b>            (only in centre with Micrograin)  <input type="checkbox"/> 1      <input type="checkbox"/> 2</p>	01.05.2005 – 28.02.2013 01.02.2009 – 28.02.2013	3065183 3081093	Units _____ _____	/m <sup>2</sup> /m <sup>2</sup>	
	<p><b>* Place a cross next to the door section!</b></p> <p><b>Hinge for wicket door</b></p>	09.07.2001 –	3042410	Units _____	/each	

+<sup>1</sup> Surcharge for door sections in preferred colour and RAL to choose, see pages 135 – 136/indicate RAL colour article number

+<sup>2</sup> Surcharge for compound glazing, see page 83 – 84/indicate the article number for the respective compound glazing

<b>ORDER</b>	Customer no.: _____	Order no./com.: _____	<b>*Please take information from the data label!</b>	
			Order no.:	Door no.:
	Customer name: _____		Product no.:	Type:
	Shipping address: _____		Year of manufacture:	
	Place/date: _____		Stamp and signature	

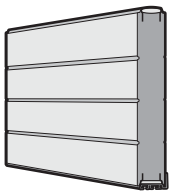
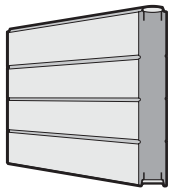
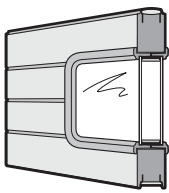
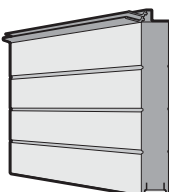
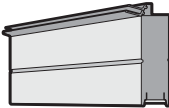

## 2. Double-Skinned Door Sections 80 mm

Article	Description	Production period	Art. no.	Qty.	€
	* <b>Bottom door section, double-skinned 80 mm, 500, ribbed</b> Based on RAL _____	01.10.2005 – 28.02.2013	3072871 _____	Units _____ _____	/m <sup>2</sup> + <sup>1</sup>
	* <b>Door section, double-skinned 80 mm, 500, ribbed</b> Based on RAL _____	01.10.2005 – 28.02.2013	3072872 _____	Units _____ _____	/m <sup>2</sup> + <sup>1</sup>
	* <b>Door section, double-skinned 80 mm, 500, ribbed, with compound glazing type A</b> Based on RAL _____ Compound glazing version	01.10.2005 – 28.02.2013	3072873 _____ _____	Units _____ _____ _____	/m <sup>2</sup> + <sup>1</sup> + <sup>2</sup>
	* <b>Top door section, double-skinned 80 mm, 500, ribbed, with lintel seal</b> Based on RAL _____	01.10.2005 – 28.02.2013	3072874 _____	Units _____ _____	/m <sup>2</sup> + <sup>1</sup>
	* <b>Top door section, double-skinned 80 mm, ribbed, for intermediate height, with lintel seal</b> Based on RAL _____	01.10.2005 – 28.02.2013	3072875 _____	Units _____ _____	/m <sup>2</sup> + <sup>1</sup>

+<sup>1</sup> Surcharge for door sections in preferred colour and RAL to choose, see pages 135 – 136/indicate RAL colour article number

+<sup>2</sup> Surcharge for compound glazing type A, see page 83/indicate the article number for the respective compound glazing

F = per field

<b>ORDER</b>	Customer no.: _____	Order no./com.: _____	<b>*Please take information from the data label!</b>	
			Order no.: _____	Door no.: _____
	Customer name: _____		Product no.: _____	Type: _____
	Shipping address: _____		Year of manufacture: _____	
	Place/date: _____		Stamp and signature _____	

### 3. Door Sections Made of Aluminium Profiles

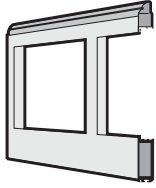
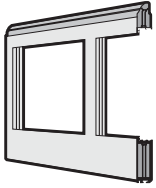
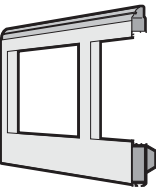
Article	Description	Production period	Art. no.	Qty.	€		
	<p><b>* Bottom door section, frame made of standard profiles, up to door widths of 5500 mm</b></p> <p>Type N Type B Based on RAL _____ Infill _____ Infill based on RAL _____ Surcharge for aluminium glazing beads Surcharge for painted glazing beads Surcharge per ventilation grille</p>	<p>09.07.2001 – 28.02.2013 01.03.2003 – 28.02.2013</p>	<p>3041960 3059753 _____ _____ 3087577 3087576 _____</p>	<p>Units _____ _____ _____ _____ _____ _____ _____</p>	<p>/m<sup>2</sup> /m<sup>2</sup> +<sup>1</sup> +<sup>3</sup> +<sup>4</sup> /F /F +<sup>5</sup></p>		
		<p><b>* Bottom door section, frame made of thermal break profiles Up to door widths of 5500 mm</b></p> <p>Based on RAL _____ Infill _____ Infill based on RAL _____ Surcharge for aluminium glazing beads Surcharge for painted glazing beads Surcharge per ventilation grille</p>	<p>09.07.2001 – 28.02.2013</p>	<p>3041962 _____ _____ 3087577 3087576 _____</p>	<p>Units _____ _____ _____ _____ _____ _____</p>	<p>/m<sup>2</sup> +<sup>1</sup> +<sup>3</sup> +<sup>4</sup> /F /F +<sup>5</sup></p>	
			<p><b>* Bottom door section, frame made of standard profiles</b></p> <p>Type N from door widths of 5510 mm incl. door leaf reinforcement Type B from door widths of 5510 mm incl. door leaf reinforcement Type ALS (infill required) Based on RAL _____ Infill _____ Infill based on RAL _____ Surcharge for aluminium glazing beads Surcharge for painted glazing beads Surcharge per ventilation grille</p>	<p>09.07.2001 – 28.02.2013 01.03.2003 – 28.02.2013 01.03.2004 – 28.02.2013</p>	<p>3041961 3059754 3062075 _____ _____ 3087577 3087576 _____</p>	<p>Units _____ _____ _____ _____ _____ _____ _____</p>	<p>/m<sup>2</sup> /m<sup>2</sup> /m<sup>2</sup> +<sup>1</sup> +<sup>3</sup> +<sup>4</sup> /F /F +<sup>5</sup></p>

+<sup>1</sup> Surcharge for door sections in preferred colour and RAL to choose, see pages 135 – 136/indicate RAL colour article number

+<sup>3</sup> Surcharge for infill, see pages 76 – 79

+<sup>4</sup> Surcharge for infill colour, see page 136

+<sup>5</sup> Surcharge per ventilation grille, see page 86

F = per field

<b>ORDER</b>	Customer no.:	Order no./com.:	<b>*Please take information from the data label!</b>	
			Order no.:	Door no.:
	Customer name:		Product no.:	Type:
	Shipping address: _____		Year of manufacture:	
	Place/date:		Stamp and signature	

### 3. Door Sections Made of Aluminium Profiles

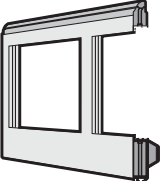
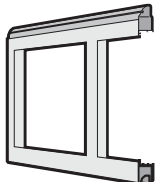
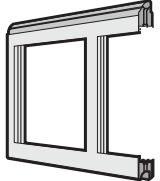
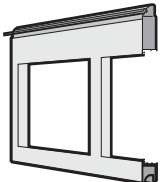
Article	Description	Production period	Art. no.	Qty.	€	
	<p><b>* Bottom door section, frame made of thermal break profiles</b>  <b>From door widths of 5510 mm</b>                      (infill and TBV are required)                      Based on RAL _____                      Infill _____                      Infill based on RAL _____                      Surcharge for aluminium glazing beads                      Surcharge for painted glazing beads                      Surcharge per ventilation grille</p>	09.07.2001 – 28.02.2013	3041963	Units	/m <sup>2</sup>	
					+1	
						+3
						+4
				3087577		/F
				3087576		/F
					+5	
	<p><b>* Door section, frame made of standard profiles</b>                      Type N                      Type B                      Type ALS (infill required)                      Based on RAL _____                      Infill _____                      Infill based on RAL _____                      Surcharge for aluminium glazing beads                      Surcharge for painted glazing beads                      Surcharge per ventilation grille</p>	09.07.2001 – 28.02.2013	3041285	Units	/m <sup>2</sup>	
		01.03.2003 – 28.02.2013	3059755		/m <sup>2</sup>	
		01.03.2004 – 28.02.2013	3062076		/m <sup>2</sup>	
					+1	
					+3	
				3087577		/F
			3087576		/F	
					+5	
	<p><b>* Door section, frame made of thermal break profiles</b>                      Based on RAL _____                      Infill _____                      Infill based on RAL _____                      Surcharge for aluminium glazing beads                      Surcharge for painted glazing beads                      Surcharge per ventilation grille</p>	09.07.2001 – 28.02.2013	3041287	Units	/m <sup>2</sup>	
					+1	
						+3
						+4
				3087577		/F
				3087576		/F
					+5	
	<p><b>* Top door section, frame made of standard profiles, with lintel seal</b>                      Type N                      Type B                      Type ALS (infill required)                      Based on RAL _____                      Infill _____                      Infill based on RAL _____                      Surcharge for aluminium glazing beads                      Surcharge for painted glazing beads</p>	09.07.2001 – 28.02.2013	3041760	Units	/m <sup>2</sup>	
		09.07.2001 – 28.02.2013	3059756		/m <sup>2</sup>	
		01.03.2004 – 28.02.2013	3062077		/m <sup>2</sup>	
					+1	
					+3	
				3087577		/F
			3087576		/F	
					+5	

+1 Surcharge for door sections in preferred colour and RAL to choose, see pages 135 – 136/indicate RAL colour article number

+3 Surcharge for infill, see pages 76 – 79

+4 Surcharge for infill colour, see page 136

+5 Surcharge per ventilation grille, see page 86

F = per field

<b>ORDER</b>	Customer no.: _____ Order no./com.: _____		<b>*Please take information from the data label!</b>	
			Order no.:	Door no.:
	Customer name: _____		Product no.:	Type:
	Shipping address: _____		Year of manufacture: _____	
	Place/date: _____		Stamp and signature _____	

### 3. Door Sections Made of Aluminium Profiles

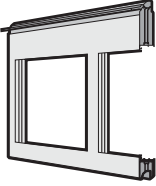
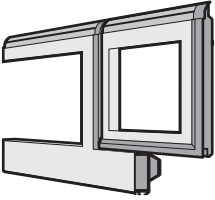
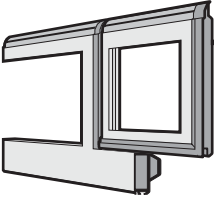
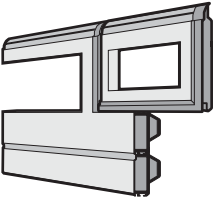
Article	Description	Production period	Art. no.	Qty.	€
	<p><b>* Top door section, frame made of thermal break profiles, with lintel seal</b>            Based on RAL _____            Infill _____            Infill based on RAL _____            Surcharge for aluminium glazing beads            Surcharge for painted glazing beads</p>	09.07.2001 – 28.02.2013	3041761 _____ _____ 3087577 3087576	Units _____ _____ _____ _____ _____	/m <sup>2</sup> + <sup>1</sup> + <sup>3</sup> + <sup>4</sup> /F /F
	<p><b>* Bottom door section, frame made of standard profiles, with wicket door</b>  <b>Up to door widths of 5500 mm</b>            Based on RAL _____            Infill _____            Infill based on RAL _____            Surcharge for aluminium glazing beads            Surcharge for painted glazing beads            Surcharge per ventilation grille</p>	09.07.2001 – 28.02.2013	3087668 _____ _____ 3087577 3087576 _____	Units _____ _____ _____ _____ _____	/m <sup>2</sup> + <sup>1</sup> + <sup>3</sup> + <sup>4</sup> /F /F + <sup>5</sup>
	<p><b>* Bottom door section, frame made of thermal break profiles, with wicket door</b>  <b>Up to door widths of 5500 mm</b>            Based on RAL _____            Infill _____            Infill based on RAL _____            Surcharge for aluminium glazing beads            Surcharge for painted glazing beads            Surcharge per ventilation grille</p>	09.07.2001 – 28.02.2013	3087678 _____ _____ 3087577 3087576 _____	Units _____ _____ _____ _____ _____	/m <sup>2</sup> + <sup>1</sup> + <sup>3</sup> + <sup>4</sup> /F /F + <sup>5</sup>
	<p><b>* Bottom door section, frame made of standard profiles, with wicket door</b>  <b>From door widths of 5510 mm</b>            Based on RAL _____            Infill _____            Infill based on RAL _____            Surcharge for aluminium glazing beads            Surcharge for painted glazing beads            Surcharge per ventilation grille</p>	09.07.2001 – 28.02.2013	3087669 _____ _____ 3087577 3087576 _____	Units _____ _____ _____ _____ _____	/m <sup>2</sup> + <sup>1</sup> + <sup>3</sup> + <sup>4</sup> /F /F + <sup>5</sup>

+<sup>1</sup> Surcharge for door sections in preferred colour and RAL to choose, see pages 135 – 136/indicate RAL colour article number

+<sup>3</sup> Surcharge for infill, see pages 76 – 79

+<sup>4</sup> Surcharge for infill colour, see page 136

+<sup>5</sup> Surcharge per ventilation grille, see page 86

F = per field

<b>ORDER</b>	Customer no.:	Order no./com.:	<b>*Please take information from the data label!</b>	
	Customer name:	Shipping address:	Order no.:	Door no.:
	Place/date:		Product no.:	Type:
			Year of manufacture:	
			Stamp and signature	

### 3. Door Sections Made of Aluminium Profiles

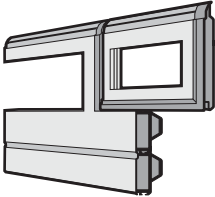
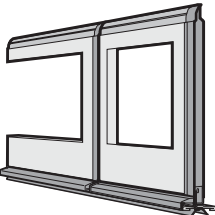
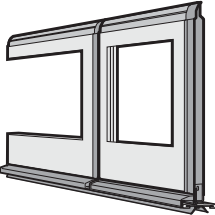
Article	Description	Production period	Art. no.	Qty.	€	
	<p><b>* Bottom door section, frame made of thermal break profiles, with wicket door</b>  <b>From door widths of 5510 mm</b>            Based on RAL _____            Infill _____            Infill based on RAL _____            Surcharge for aluminium glazing beads            Surcharge for painted glazing beads            Surcharge per ventilation grille</p>	09.07.2001 – 28.02.2013	3087679	Units	/m <sup>2</sup>	
			_____	_____	_____	+1
			_____	_____	_____	+3
			_____	_____	_____	+4
			3087577	_____	_____	/F
	3087576	_____	_____	_____	/F	
	_____	_____	_____	_____	+5	
	<p><b>* Bottom door section, frame made of standard profiles, with wicket door with trip-free threshold, with stainless steel bottom profile</b>            Up to door widths of 5500 mm            From door widths of 5510 mm            Based on RAL _____            Infill _____            Infill based on RAL _____            Surcharge for aluminium glazing beads            Surcharge for painted glazing beads            Surcharge per ventilation grille</p>	01.05.2005 – 28.02.2013 02.11.2005 – 28.02.2013	3087670	Units	/m <sup>2</sup>	
			3087671	_____	_____	/m <sup>2</sup>
			_____	_____	_____	+1
			_____	_____	_____	+3
			3087577	_____	_____	+4
	3087576	_____	_____	/F		
	_____	_____	_____	/F		
	_____	_____	_____	_____	+5	
	<p><b>* Bottom door section, frame made of thermal break profiles, with wicket door with trip-free threshold, with stainless steel bottom profile</b>            Up to door widths of 5500 mm            From door widths of 5510 mm            Based on RAL _____            Infill _____            Infill based on RAL _____            Surcharge for aluminium glazing beads            Surcharge for painted glazing beads            Surcharge per ventilation grille</p>	01.05.2005 – 28.02.2013 02.11.2005 – 28.02.2013	3087680	Units	/m <sup>2</sup>	
			3087681	_____	_____	/m <sup>2</sup>
			_____	_____	_____	+1
			_____	_____	_____	+3
			3087577	_____	_____	+4
	3087576	_____	_____	/F		
	_____	_____	_____	/F		
	_____	_____	_____	_____	+5	

+1 Surcharge for door sections in preferred colour and RAL to choose, see pages 135 – 136/indicate RAL colour article number

+3 Surcharge for infill, see pages 76 – 79

+4 Surcharge for infill colour, see page 136

+5 Surcharge per ventilation grille, see page 86

F = per field

<b>ORDER</b>	Customer no.:	Order no./com.:	<b>*Please take information from the data label!</b>	
			Order no.:	Door no.:
	Customer name:		Product no.:	Type:
	Shipping address:		Year of manufacture:	
	Place/date:		Stamp and signature	

### 3. Door Sections Made of Aluminium Profiles

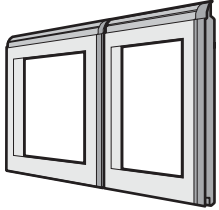
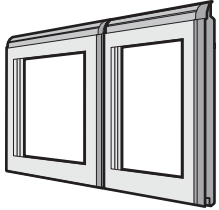
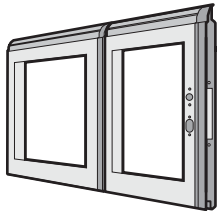
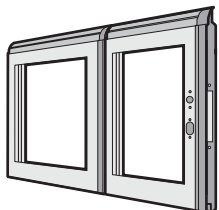
Article	Description	Production period	Art. no.	Qty.	€
	<p><b>* Door section, frame made of standard profiles, with wicket door</b>            Based on RAL _____            Infill _____            Infill based on RAL _____            Surcharge for aluminium glazing beads            Surcharge for painted glazing beads            Surcharge per ventilation grille</p>	09.07.2001 – 28.02.2013	3087672 _____ _____ 3087577 3087576 _____	Units _____ _____ _____ _____ _____	/m <sup>2</sup> + <sup>1</sup> + <sup>3</sup> + <sup>4</sup> /F /F + <sup>5</sup>
	<p><b>* Door section, frame made of thermal break profiles, with wicket door</b>            Based on RAL _____            Infill _____            Infill based on RAL _____            Surcharge for aluminium glazing beads            Surcharge for painted glazing beads            Surcharge per ventilation grille</p>	09.07.2001 – 28.02.2013	3087682 _____ _____ 3087577 3087576 _____	Units _____ _____ _____ _____ _____	/m <sup>2</sup> + <sup>1</sup> + <sup>3</sup> + <sup>4</sup> /F /F + <sup>5</sup>
	<p><b>* Door section, frame made of standard profiles, with wicket door for lock</b>            Based on RAL _____            Infill _____            Infill based on RAL _____            Surcharge for aluminium glazing beads            Surcharge for painted glazing beads            Surcharge per ventilation grille</p>	09.07.2001 – 28.02.2013	3087673 _____ _____ 3087577 3087576 _____	Units _____ _____ _____ _____ _____	/m <sup>2</sup> + <sup>1</sup> + <sup>3</sup> + <sup>4</sup> /F /F + <sup>5</sup>
	<p><b>* Door section, frame made of thermal break profiles, for lock plate, with wicket door for lock</b>            Based on RAL _____            Infill _____            Infill based on RAL _____            Surcharge for aluminium glazing beads            Surcharge for painted glazing beads            Surcharge per ventilation grille</p>	09.07.2001 – 28.02.2013	3087683 _____ _____ 3087577 3087576 _____	Units _____ _____ _____ _____ _____	/m <sup>2</sup> + <sup>1</sup> + <sup>3</sup> + <sup>4</sup> /F /F + <sup>5</sup>

+<sup>1</sup> Surcharge for door sections in preferred colour and RAL to choose, see pages 135 – 136/indicate RAL colour article number

+<sup>3</sup> Surcharge for infill, see pages 76 – 79

+<sup>4</sup> Surcharge for infill colour, see page 136

+<sup>5</sup> Surcharge per ventilation grille, see page 86

F = per field

<b>ORDER</b>	Customer no.: _____	Order no./com.: _____	<b>*Please take information from the data label!</b>	
			Order no.:	Door no.:
	Customer name: _____		Product no.:	Type:
	Shipping address: _____		Year of manufacture:	
	Place/date: _____		Stamp and signature	

### 3. Door Sections Made of Aluminium Profiles

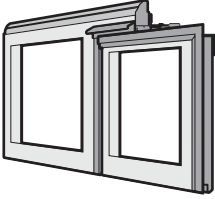
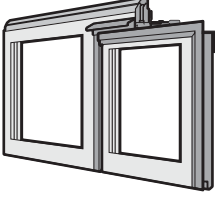
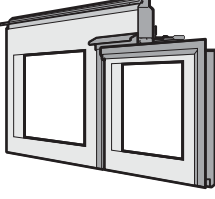
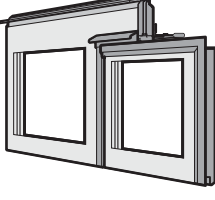
Article	Description	Production period	Art. no.	Qty.	€
	<p><b>* Top door section, frame made of standard profiles, with wicket door, without lintel seal</b>            Based on RAL _____            Infill _____            Infill based on RAL _____            Surcharge for aluminium glazing beads            Surcharge for painted glazing beads</p>	09.07.2001 – 28.02.2013	3087674 _____ _____ 3087577 3087576	Units _____ _____ _____ _____ _____	/m <sup>2</sup> +1 +3 +4 /F /F
	<p><b>* Top door section, frame made of thermal break profiles, with wicket door, without lintel seal</b>            Based on RAL _____            Infill _____            Infill based on RAL _____            Surcharge for aluminium glazing beads            Surcharge for painted glazing beads</p>	09.07.2001 – 28.02.2013	3087684 _____ _____ 3087577 3087576	Units _____ _____ _____ _____ _____	/m <sup>2</sup> +1 +3 +4 /F /F
	<p><b>* Top door section, frame made of standard profiles, with wicket door, with lintel seal</b>            Based on RAL _____            Infill _____            Infill based on RAL _____            Surcharge for aluminium glazing beads            Surcharge for painted glazing beads</p>	09.07.2001 – 28.02.2013	3087675 _____ _____ 3087577 3087576	Units _____ _____ _____ _____ _____	/m <sup>2</sup> +1 +3 +4 /F /F
	<p><b>* Top door section, frame made of thermal break profiles, with wicket door, with lintel seal</b>            Based on RAL _____            Infill _____            Infill based on RAL _____            Surcharge for aluminium glazing beads            Surcharge for painted glazing beads</p>	09.07.2001 – 28.02.2013	3087685 _____ _____ 3087577 3087576	Units _____ _____ _____ _____ _____	/m <sup>2</sup> +1 +3 +4 /F /F

+1 Surcharge for door sections in preferred colour and RAL to choose, see pages 135 – 136/indicate RAL colour article number

+3 Surcharge for infill, see pages 76 – 79



+4 Surcharge for infill colour, see page 136

+5 Surcharge per ventilation grille, see page 86

F = per field

<b>ORDER</b>	Customer no.: _____	Order no./com.: _____	<b>*Please take information from the data label!</b>	
			Order no.:	Door no.:
	Customer name: _____		Product no.:	Type:
	Shipping address: _____		Year of manufacture:	
	Place/date: _____		Stamp and signature	

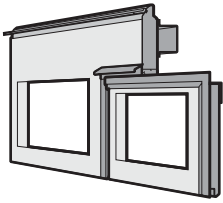
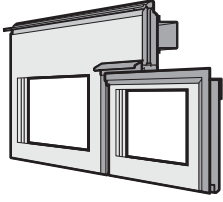
### 3. Door Sections Made of Aluminium Profiles

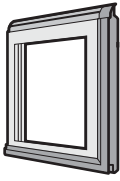
Article	Description	Production period	Art. no.	Qty.	€			
	<p><b>* Top door section, frame made of standard profiles, with wicket door with trip-free threshold and lintel seal</b></p> <p>Up to door widths of 5500 mm            From door widths of 5510 mm            Based on RAL _____            Infill _____            Infill based on RAL _____            Surcharge for aluminium glazing beads            Surcharge for painted glazing beads</p>	<p>01.05.2005 – 28.02.2013            02.11.2005 – 28.02.2013</p>	<p>3087676            3087677            _____            _____            3087577            3087576</p>	<p>Units            _____            _____            _____            _____            _____            _____</p>	<p>/m<sup>2</sup>            /m<sup>2</sup>            +<sup>1</sup>            +<sup>3</sup>            +<sup>4</sup>            /F            /F</p>			
		<p><b>* Top door section, frame made of thermal break profiles, with wicket door with trip-free threshold and lintel seal</b></p> <p>Up to door widths of 5500 mm            From door widths of 5510 mm            Based on RAL _____            Infill _____            Infill based on RAL _____            Surcharge for aluminium glazing beads            Surcharge for painted glazing beads</p>	<p>01.05.2005 – 28.02.2013            02.11.2005 – 28.02.2013</p>	<p>3087686            3087687            _____            _____            3087577            3087576</p>	<p>Units            _____            _____            _____            _____            _____            _____</p>	<p>/m<sup>2</sup>            /m<sup>2</sup>            +<sup>1</sup>            +<sup>3</sup>            +<sup>4</sup>            /F            /F</p>		
			<p><b>* Bottom wicket door section, frame made of standard profiles</b></p> <p>Based on RAL _____            Infill _____            Infill based on RAL _____            Surcharge for aluminium glazing beads            Surcharge for painted glazing beads            If hinge is required for wicket door</p>	<p>09.07.2001 – 28.02.2013</p>	<p>3042331            _____            _____            3087577            3087576            3042410</p>	<p>Units            _____            _____            _____            _____            _____</p>	<p>/each            +<sup>1</sup>            +<sup>3</sup>            +<sup>4</sup>            /F            /F            /each</p>	
				<p><b>* Bottom wicket door section, frame made of thermal break profiles</b></p> <p>Based on RAL _____            Infill _____            Infill based on RAL _____            Surcharge for aluminium glazing beads            Surcharge for painted glazing beads            If hinge is required for wicket door</p>	<p>09.07.2001 – 28.02.2013</p>	<p>3042332            _____            _____            3087577            3087576            3042410</p>	<p>Units            _____            _____            _____            _____            _____</p>	<p>/each            +<sup>1</sup>            +<sup>3</sup>            +<sup>4</sup>            /F            /F            /each</p>

+<sup>1</sup> Surcharge for door sections in preferred colour and RAL to choose, see pages 135 – 136/indicate RAL colour article number

+<sup>3</sup> Surcharge for infill, see pages 76 – 79

+<sup>4</sup> Surcharge for infill colour, see page 136

+<sup>5</sup> Surcharge per ventilation grille, see page 86

F = per field

<b>ORDER</b>	Customer no.: _____	Order no./com.: _____	<b>*Please take information from the data label!</b>	
			Order no.:	Door no.:
	Customer name: _____		Product no.:	Type:
	Shipping address: _____		Year of manufacture:	
	Place/date: _____		Stamp and signature _____	

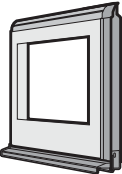
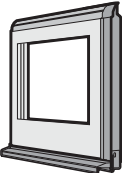
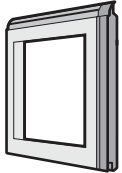
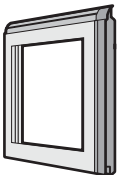

### 3. Door Sections Made of Aluminium Profiles

Article	Description	Production period	Art. no.	Qty.	€		
	<p><b>* Bottom wicket door section, frame made of standard profiles, for wicket door with trip-free threshold, with stainless steel bottom profile</b></p> <p>Based on RAL _____</p> <p>Infill _____</p> <p>Infill based on RAL _____</p> <p>Surcharge for aluminium glazing beads</p> <p>Surcharge for painted glazing beads</p> <p>If hinge is required for wicket door</p>	01.05.2005 – 28.02.2013	3065063	Units	/each		
						+ <sup>1</sup>	
							+ <sup>3</sup>
							+ <sup>4</sup>
					3087577		/F
					3087576		/F
			3042410		/each		
	<p><b>* Bottom wicket door section, frame made of thermal break profiles, for wicket door with trip-free threshold, with stainless steel bottom profile</b></p> <p>Based on RAL _____</p> <p>Infill _____</p> <p>Infill based on RAL _____</p> <p>Surcharge for aluminium glazing beads</p> <p>Surcharge for painted glazing beads</p> <p>If hinge is required for wicket door</p>	01.05.2005 – 28.02.2013	3065064	Units	/each		
						+ <sup>1</sup>	
							+ <sup>3</sup>
							+ <sup>4</sup>
					3087577		/F
					3087576		/F
			3042410		/each		
	<p><b>* Wicket door section, frame made of standard profiles</b></p> <p>Based on RAL _____</p> <p>Infill _____</p> <p>Infill based on RAL _____</p> <p>Surcharge for aluminium glazing beads</p> <p>Surcharge for painted glazing beads</p> <p>If hinge is required for wicket door</p>	09.07.2001 – 28.02.2013	3042333	Units	/each		
						+ <sup>1</sup>	
							+ <sup>3</sup>
							+ <sup>4</sup>
					3087577		/F
					3087576		/F
			3042410		/each		
	<p><b>* Wicket door section, frame made of thermal break profiles</b></p> <p>Based on RAL _____</p> <p>Infill _____</p> <p>Infill based on RAL _____</p> <p>Surcharge for aluminium glazing beads</p> <p>Surcharge for painted glazing beads</p> <p>If hinge is required for wicket door</p>	09.07.2001 – 28.02.2013	3042334	Units	/each		
						+ <sup>1</sup>	
							+ <sup>3</sup>
							+ <sup>4</sup>
					3087577		/F
					3087576		/F
			3042410		/each		

+<sup>1</sup> Surcharge for door sections in preferred colour and RAL to choose, see pages 135 – 136/indicate RAL colour article number

+<sup>3</sup> Surcharge for infill, see pages 76 – 79





+<sup>4</sup> Surcharge for infill colour, see page 136

+<sup>5</sup> Surcharge per ventilation grille, see page 86

F = per field

<b>ORDER</b>	Customer no.:	Order no./com.:	<b>*Please take information from the data label!</b>	
			Order no.:	Door no.:
	Customer name:		Product no.:	Type:
	Shipping address:		Year of manufacture:	
	Place/date:		Stamp and signature	

### 3. Door Sections Made of Aluminium Profiles

Article	Description	Production period	Art. no.	Qty.	€
	<p><b>Wicket door section for lock, frame made of standard profiles</b></p> <p>Based on RAL _____</p> <p>Infill _____</p> <p>Infill based on RAL _____</p> <p>Surcharge for aluminium glazing beads</p> <p>Surcharge for painted glazing beads</p> <p>If hinge is required for wicket door</p>	09.07.2001 – 28.02.2013	3042335	Units	/each
			_____	_____	+ <sup>1</sup>
			_____	_____	+ <sup>3</sup>
			_____	_____	+ <sup>4</sup>
			3087577	_____	/F
			3087576	_____	/F
3042410	_____	/each			
	<p><b>Wicket door section for lock, frame made of standard profiles</b></p> <p>Based on RAL _____</p> <p>Infill _____</p> <p>Infill based on RAL _____</p> <p>Surcharge for aluminium glazing beads</p> <p>Surcharge for painted glazing beads</p> <p>If hinge is required for wicket door</p>	09.07.2001 – 28.02.2013	3042336	Units	/each
			_____	_____	+ <sup>1</sup>
			_____	_____	+ <sup>3</sup>
			_____	_____	+ <sup>4</sup>
			3087577	_____	/F
			3087576	_____	/F
3042410	_____	/each			
	<p><b>Top wicket door section, frame made of standard profiles</b></p> <p>For top door section and wicket door with threshold rail</p> <p>For intermediate door section</p> <p>Based on RAL _____</p> <p>Infill _____</p> <p>Infill based on RAL _____</p> <p>Surcharge for aluminium glazing beads</p> <p>Surcharge for painted glazing beads</p> <p>If hinge is required for wicket door</p>	09.07.2001 – 28.02.2013	3042337	Units	/each
		09.07.2001 – 28.02.2013	3090165	_____	/each
		_____	_____	+ <sup>1</sup>	
		_____	_____	+ <sup>3</sup>	
		_____	_____	+ <sup>4</sup>	
		3087577	_____	/F	
3087576	_____	/F			
3042410	_____	/each			
	<p><b>Top wicket door section, frame made of standard profiles</b></p> <p>For top door section and wicket door with threshold rail</p> <p>For intermediate door section</p> <p>Based on RAL _____</p> <p>Infill _____</p> <p>Infill based on RAL _____</p> <p>Surcharge for aluminium glazing beads</p> <p>Surcharge for painted glazing beads</p> <p>If hinge is required for wicket door</p>	09.07.2001 – 28.02.2013	3042338	Units	/each
		09.07.2001 – 28.02.2013	3090166	_____	/each
		_____	_____	+ <sup>1</sup>	
		_____	_____	+ <sup>3</sup>	
		_____	_____	+ <sup>4</sup>	
		3087577	_____	/F	
3087576	_____	/F			
3042410	_____	/each			

+<sup>1</sup> Surcharge for door sections in preferred colour and RAL to choose, see pages 135 – 136/indicate RAL colour article number

+<sup>3</sup> Surcharge for infill, see pages 76 – 79

+<sup>4</sup> Surcharge for infill colour, see page 136

+<sup>5</sup> Surcharge per ventilation grille, see page 86

F = per field

<b>ORDER</b>	Customer no.: _____	Order no./com.: _____	<b>*Please take information from the data label!</b>	
			Order no.:	Door no.:
	Customer name: _____		Product no.:	Type:
	Shipping address: _____		Year of manufacture:	
	Place/date: _____		Stamp and signature	

### 3. Door Sections Made of Aluminium Profiles

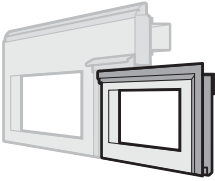
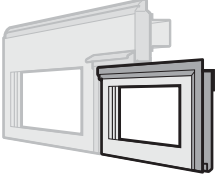
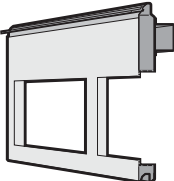
Article	Description	Production period	Art. no.	Qty.	€		
	<p><b>* Top wicket door section, frame made of standard profiles, for the topmost door section and wicket doors with trip-free threshold</b></p> <p>Based on RAL _____</p> <p>Infill _____</p> <p>Infill based on RAL _____</p> <p>Surcharge for aluminium glazing beads</p> <p>Surcharge for painted glazing beads</p> <p>If hinge is required for wicket door</p>	01.05.2005 – 28.02.2013	3065065	Units			
						/each	
							+1
							+3
							+4
	<p><b>* Top wicket door section, frame made of standard profiles, for the topmost door section and wicket doors with trip-free threshold</b></p> <p>Based on RAL _____</p> <p>Infill _____</p> <p>Infill based on RAL _____</p> <p>Surcharge for aluminium glazing beads</p> <p>Surcharge for painted glazing beads</p> <p>If hinge is required for wicket door</p>	01.05.2005 – 28.02.2013	3065066	Units			
						/each	
							+1
							+3
							+4
	<p><b>* Top door section, frame made of standard profiles, above the wicket door with trip-free threshold, with lintel seal</b></p> <p>Up to door widths of 5500 mm</p> <p>From door widths of 5510 mm</p> <p>Based on RAL _____</p> <p>Infill _____</p> <p>Infill based on RAL _____</p> <p>Surcharge for aluminium glazing beads</p> <p>Surcharge for painted glazing beads</p>	01.05.2005 – 28.02.2013	3065067	Units			
		02.11.2005 – 28.02.2013	3072865		/m <sup>2</sup>		
						+1	
						+3	
						+4	
			3087577		/F		
			3087576		/F		

+1 Surcharge for door sections in preferred colour and RAL to choose, see pages 135 – 136/indicate RAL colour article number

+3 Surcharge for infill, see pages 76 – 79

+4 Surcharge for infill colour, see page 136

+5 Surcharge per ventilation grille, see page 86

F = per field

<b>ORDER</b>	Customer no.: _____	Order no./com.: _____	<b>*Please take information from the data label!</b>	
			Order no.:	Door no.:
	Customer name: _____		Product no.:	Type:
	Shipping address: _____		Year of manufacture:	
	Place/date: _____		Stamp and signature	

### 3. Door Sections Made of Aluminium Profiles

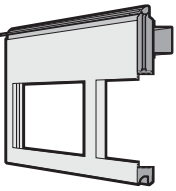
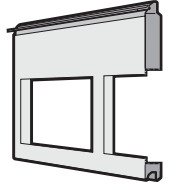
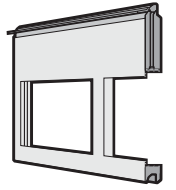
Article	Description	Production period	Art. no.	Qty.	€
	<p><b>* Top door section, frame made of thermal break profiles, above the wicket door with trip-free threshold, with lintel seal</b></p> <p>Up to door widths of 5500 mm            From door widths of 5510 mm            Based on RAL _____            Infill _____            Infill based on RAL _____            Surcharge for aluminium glazing beads            Surcharge for painted glazing beads</p>	01.05.2005 – 28.02.2013 02.11.2005 – 28.02.2013	3065068	Units	/m <sup>2</sup>
			3072866		/m <sup>2</sup>
					+ <sup>1</sup>
					+ <sup>3</sup>
					+ <sup>4</sup>
					/F
	<p><b>* Top door section, frame made of standard profiles, matching the frame above the wicket door with trip-free threshold, with lintel seal</b></p> <p>Based on RAL _____            Infill _____            Infill based on RAL _____            Surcharge for aluminium glazing beads            Surcharge for painted glazing beads</p>	01.05.2005 – 28.02.2013	3065069	Units	/m <sup>2</sup>
					+ <sup>1</sup>
					+ <sup>3</sup>
					+ <sup>4</sup>
					/F
					/F
	<p><b>* Top door section, frame made of thermal break profiles, matching the frame above the wicket door with trip-free threshold, with lintel seal</b></p> <p>Based on RAL _____            Infill _____            Infill based on RAL _____            Surcharge for aluminium glazing beads            Surcharge for painted glazing beads</p>	01.05.2005 – 28.02.2013	3065070	Units	/m <sup>2</sup>
					+ <sup>1</sup>
					+ <sup>3</sup>
					+ <sup>4</sup>
					/F
					/F

- +<sup>1</sup> Surcharge for door sections in preferred colour and RAL to choose, see pages 135 – 136/indicate RAL colour article number
- +<sup>3</sup> Surcharge for infill, see pages 76 – 79
- +<sup>4</sup> Surcharge for infill colour, see page 136
- +<sup>5</sup> Surcharge per ventilation grille, see page 86
- F = per field

ORDER	Customer no.: _____ Order no./com.: _____		<b>*Please take information from the data label!</b>	
			Order no.:	Door no.:
	Customer name: _____		Product no.:	Type:
	Shipping address: _____		Year of manufacture: _____	
	Place/date: _____		Stamp and signature _____	

### 3. Door Sections Made of Aluminium Profiles

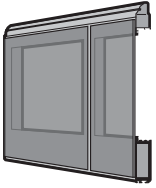
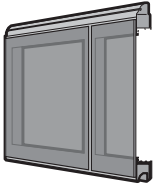
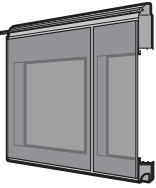
Article	Description	Production period	Art. no.	Qty.	€
	<p><b>* Bottom door section, frame made of standard profiles, for Vitraplan with glazing fitted in front</b>                      (infill required, from 5510 mm, incl. door leaf reinforcement)                      Infill _____                      Surcharge for aluminium glazing beads                      Surcharge for painted glazing beads  <b>Glazing fitted in front:</b>                      (colour)  <input type="checkbox"/> Brown    <input type="checkbox"/> Grey</p>	01.07.2009 – 28.02.2013	3087591	Units	/m <sup>2</sup>
					+ <sup>3</sup>
			3087577		/F
			3087576		/F
	<p><b>* Door section, frame made of standard profiles, for Vitraplan with glazing fitted in front</b>                      (infill required)                      Infill _____                      Surcharge for aluminium glazing beads                      Surcharge for painted glazing beads  <b>Glazing fitted in front:</b>                      (colour)  <input type="checkbox"/> Brown    <input type="checkbox"/> Grey</p>	01.07.2009 – 28.02.2013	3087592	Units	/m <sup>2</sup>
					+ <sup>3</sup>
			3087577		/F
			3087576		/F
	<p><b>* Top door section, frame made of standard profiles, for Vitraplan with glazing fitted in front</b>                      (infill required)                      Infill _____                      Surcharge for aluminium glazing beads                      Surcharge for painted glazing beads  <b>Glazing fitted in front:</b>                      (colour)  <input type="checkbox"/> Brown    <input type="checkbox"/> Grey</p>	01.07.2009 – 28.02.2013	3087593	Units	/m <sup>2</sup>
					+ <sup>3</sup>
			3087577		/F
			3087576		/F

+<sup>1</sup> Surcharge for door sections in preferred colour and RAL to choose, see pages 135 – 136/indicate RAL colour article number

+<sup>3</sup> Surcharge for infill, see pages 76 – 79

+<sup>4</sup> Surcharge for infill colour, see page 136

+<sup>5</sup> Surcharge per ventilation grille, see page 86

F = per field

<b>ORDER</b>	Customer no.: _____	Order no./com.: _____	<b>*Please take information from the data label!</b>	
			Order no.:	Door no.:
	Customer name: _____		Product no.:	Type:
	Shipping address: _____		Year of manufacture:	
	Place/date: _____		Stamp and signature	

### 3. Door Sections Made of Aluminium Profiles

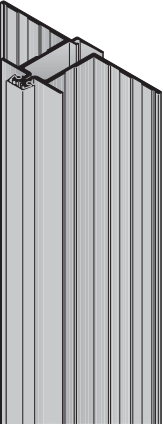
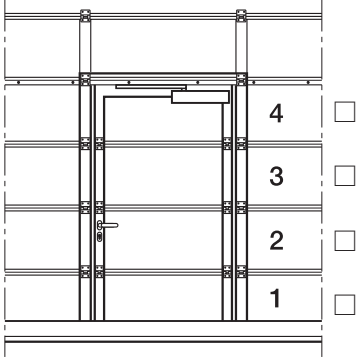
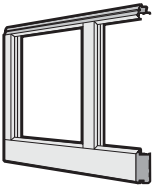
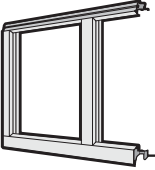
Article	Description	Production period	Art. no.	Qty.	€
	<p><b>*</b></p>  <p><b>Place a cross next to the door section!</b></p> <p><b>Hinge for wicket door</b></p>	09.07.2001 – 28.02.2013	3042410	Units	
	<p><b>*</b></p> <p><b>Bottom door section, FP profile frame</b>            Based on RAL _____            Infill _____            Infill based on RAL _____            Surcharge for aluminium glazing beads            Surcharge for painted glazing beads            Surcharge per ventilation grille</p>	01.07.2009 – 28.02.2013	3081095	Units	/m <sup>2</sup>
					+ <sup>1</sup>
					+ <sup>3</sup>
					+ <sup>4</sup>
					/F
	<p><b>*</b></p> <p><b>Door section, FP profile frame, for the first glazing frame above the PU bottom section</b>            Based on RAL _____            Infill _____            Infill based on RAL _____            Surcharge for aluminium glazing beads            Surcharge for painted glazing beads            Surcharge per ventilation grille</p>	01.07.2009 – 28.02.2013	3081096	Units	/m <sup>2</sup>
					+ <sup>1</sup>
					+ <sup>3</sup>
					+ <sup>4</sup>
					/F

+<sup>1</sup> Surcharge for door sections in preferred colour and RAL to choose, see pages 135 – 136/indicate RAL colour article number

+<sup>3</sup> Surcharge for infill, see pages 76 – 79

+<sup>4</sup> Surcharge for infill colour, see page 136

+<sup>5</sup> Surcharge per ventilation grille, see page 86

F = per field

<b>ORDER</b>	Customer no.:	Order no./com.:	<b>*Please take information from the data label!</b>	
			Order no.:	Door no.:
	Customer name:		Product no.:	Type:
	Shipping address:		Year of manufacture:	
	Place/date:		Stamp and signature	

### 3. Door Sections Made of Aluminium Profiles

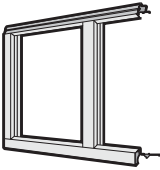
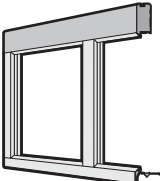
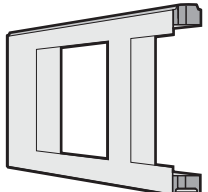
Article	Description	Production period	Art. no.	Qty.	€
	<p><b>* Door section, frame made of FP profiles</b>            Based on RAL _____            Infill _____            Infill based on RAL _____            Surcharge for aluminium glazing beads            Surcharge for painted glazing beads            Surcharge per ventilation grille</p>	01.07.2009 – 28.02.2013	3081097 _____ _____ 3087577 3087576 _____	Units _____ _____ _____ _____ _____	/m <sup>2</sup> + <sup>1</sup> + <sup>3</sup> + <sup>4</sup> /F /F + <sup>5</sup>
	<p><b>* Top door section, frame made of FP profiles</b>            Based on RAL _____            Infill _____            Infill based on RAL _____            Surcharge for aluminium glazing beads            Surcharge for painted glazing beads</p>	01.07.2009 – 28.02.2013	3081098 _____ _____ 3087577 3087576	Units _____ _____ _____ _____ _____	/m <sup>2</sup> + <sup>1</sup> + <sup>3</sup> + <sup>4</sup> /F /F
	<p><b>* Door section, frame, 80 mm</b>            Based on RAL _____            Infill _____            Surcharge for painted glazing beads</p>	01.01.2007 – 28.02.2013	3087590 _____ _____ 3087576	Units _____ _____ _____	/m <sup>2</sup> + <sup>1</sup> + <sup>3</sup> /F

+<sup>1</sup> Surcharge for door sections in preferred colour and RAL to choose, see pages 135 – 136/indicate RAL colour article number

+<sup>3</sup> Surcharge for infill, see pages 76 – 79

+<sup>4</sup> Surcharge for infill colour, see page 136

+<sup>5</sup> Surcharge per ventilation grille, see page 86

F = per field

<b>ORDER</b>	Customer no.: _____	Order no./com.: _____	<b>*Please take information from the data label!</b>	
			Order no.: _____	Door no.: _____
	Customer name: _____		Product no.: _____	Type: _____
	Shipping address: _____		Year of manufacture: _____	
	Place/date: _____		Stamp and signature _____	

## 4. Accessories for Door Sections

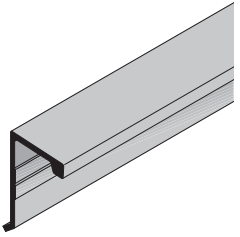
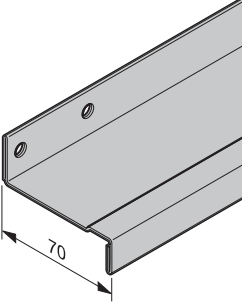
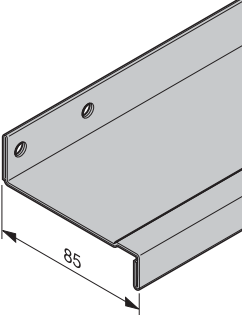
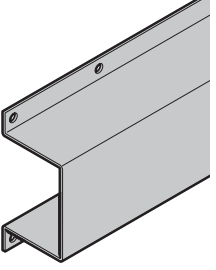
Article	Description	Production period	Art. no.	Qty.	€
	<p><b>* Reinforcement profile for bottom door section STE 40</b></p> <p>From door widths of 4010 mm (available up to a door width of 6000 mm)</p>	09.07.2001 – 29.02.2008	3042429	Units _____	/m
	<p><b>* Door leaf reinforcement 70</b></p> <p>SPU, APU, TAP, ALR, TAR 40 From door widths of 5010 to 6000 mm, for top door section, frame from door widths of 4010 to 5000 mm For top wicket door section</p>	09.07.2001 – 28.02.2013 09.07.2001 – 28.02.2013	3091365 3091366	Units _____ _____	/m /m
	<p><b>* Door leaf reinforcement 85</b></p> <p>SPU, APU, ALR 40 From door widths of 6010 to 8000 mm TAP, TAR 40 From door widths of 6010 to 7000 mm For top wicket door section</p>	09.07.2001 – 28.02.2013 09.07.2001 – 28.02.2013	3091367 3091368	Units _____ _____	/m /m
	<p><b>* Door leaf reinforcement 87 x 60</b></p> <p>DPU from door widths of 6010 mm For top door section for wicket door with trip-free threshold</p>	09.07.2001 – 28.02.2013 09.07.2001 – 28.02.2013	3065083 3091369	Units _____ _____	/m /m

+<sup>2</sup> Surcharge for infills in preferred colour and RAL to choose, see page 136 / indicate RAL colour article number.

<b>ORDER</b>	Customer no.:	Order no./com.:	<b>*Please take information from the data label!</b>	
	Customer name:	Product no.:		Door no.:
	Shipping address:	Year of manufacture:		
	Place/date:	Stamp and signature		

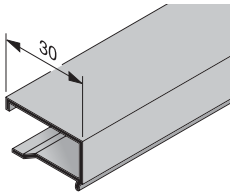
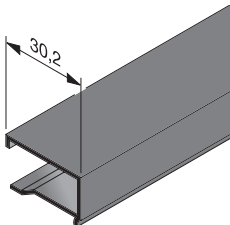
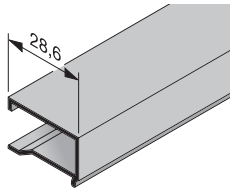
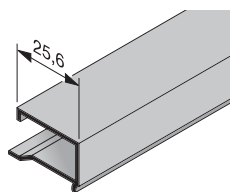

## 4. Accessories for Door Sections

Article	Description	Production period	Art. no.	Qty.	€
	<b>Aluminium glazing bead NP 1.5 infill thickness 1.5 mm</b>  Length _____ mm (max. 6500 mm) Surcharge for painted glazing beads based on RAL _____	09.07.2001 – 28.02.2013	3045672	Units	/m
			3089802		/m
	<b>Plastic glazing bead NK 1.5 infill thickness 1.5 and 3 mm</b>  Length _____ mm (max. 6000 mm)	01.06.2008 – 28.02.2013	3076914	Units	/m
	<b>Aluminium glazing bead NP 3 infill thickness 3 mm</b>  Length _____ mm (max. 6500 mm) Surcharge for painted glazing beads based on RAL _____	09.07.2001 – 28.02.2013	3045673	Units	/m
			3089802		/m
	<b>Aluminium glazing bead NF 5 infill thickness 5 mm</b>  Length _____ mm (max. 6500 mm) Surcharge for painted glazing beads based on RAL _____	09.07.2001 – 28.02.2013	3045674	Units	/m
			3089802		/m
	<b>Aluminium glazing bead NP 6 infill thickness 6 mm</b>  Length _____ mm (max. 6500 mm) Surcharge for painted glazing beads based on RAL _____	09.07.2001 – 28.02.2013	3045675	Units	/m
			3089802		/m
	<b>Plastic glazing bead NK 06 infill thickness 6 mm</b>  Length _____ mm (max. 6000 mm)	01.06.2008 – 28.02.2013	3076915	Units	/m

+<sup>2</sup> Surcharge for infills in preferred colour and RAL to choose, see page 136 / indicate RAL colour article number.

<b>ORDER</b>	Customer no.:	Order no./com.:	<b>*Please take information from the data label!</b>	
			Order no.:	Door no.:
	Customer name:		Product no.:	Type:
	Shipping address:		Year of manufacture:	
	Place/date:		Stamp and signature	

## 4. Accessories for Door Sections

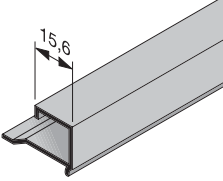
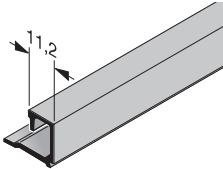
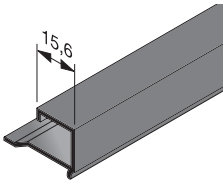
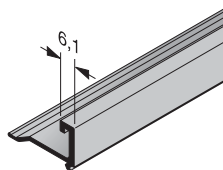
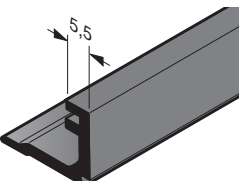
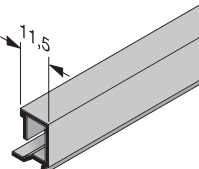
Article	Description	Production period	Art. no.	Qty.	€
	<b>Aluminium glazing bead NP 16</b> <b>infill thickness 16 mm</b> Length _____ mm (max. 6500 mm) Surcharge for painted glazing beads based on RAL _____	09.07.2001 – 28.02.2013	3045676	Units	/m
			3089802		/m
	<b>Aluminium glazing bead NFS 16</b> <b>infill thickness 16 mm</b> Length _____ mm (max. 6500 mm) Surcharge for painted glazing beads based on RAL _____	01.10.2012 – 28.02.2013	3091573	Units	/m
			3089802		/m
	<b>Plastic glazing bead NK 16</b> <b>infill thickness 16 mm</b> Length _____ mm (max. 6000 mm)	01.06.2008 – 28.02.2013	3076916	Units	/m
	<b>Aluminium glazing bead NF 26</b> <b>infill thickness 26 mm</b> Length _____ mm (max. 6500 mm) Surcharge for painted glazing beads based on RAL _____	09.07.2001 – 28.02.2013	3045950	Units	/m
			3089802		/m
	<b>Plastic glazing bead NK 26</b> <b>infill thickness 26 mm</b> Length _____ mm (max. 6000 mm)	01.06.2008 – 28.02.2013	3076917	Units	/m
	<b>Aluminium glazing bead WD 16</b> <b>infill thickness 16 mm</b> Length _____ mm (max. 6500 mm) Surcharge for painted glazing beads based on RAL _____	09.07.2001 – 28.02.2013	3045677	Units	/m
			3089802		/m

+<sup>2</sup> Surcharge for infills in preferred colour and RAL to choose, see page 136 / indicate RAL colour article number.

<b>ORDER</b>	Customer no.:	Order no./com.:	<b>*Please take information from the data label!</b>	
	Customer name:	Product no.:		Door no.:
	Shipping address:	Year of manufacture:		
	Place/date:	Stamp and signature		

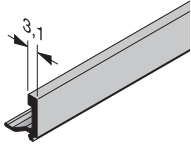
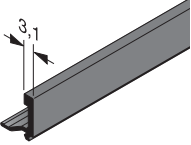
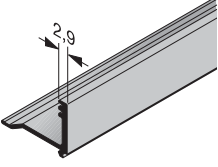
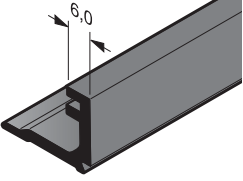
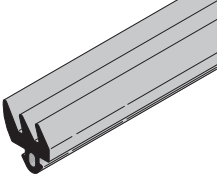
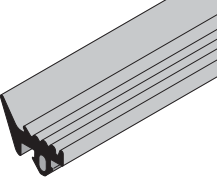

## 4. Accessories for Door Sections

Article	Description	Production period	Art. no.	Qty.	€
	<b>Aluminium glazing bead WF 26</b> <b>infill thickness 26 mm</b> Length _____ mm (max. 6500 mm) Surcharge for painted glazing beads based on RAL _____	09.07.2001 – 28.02.2013	3045951	Units _____	/m
			3089802	_____	/m
	<b>Plastic glazing bead WK 26</b> <b>infill thickness 26 mm</b> Length _____ mm (max. 6000 mm)	01.08.2010 – 28.02.2013	3089427	Units _____	/m
	<b>Aluminium glazing bead NFS 26</b> <b>infill thickness 26 mm</b> (for FP profiles) Length _____ mm (max. 6000 mm) Surcharge for painted glazing beads based on RAL _____	01.02.2009 – 28.02.2013	3087575	Units _____	/m
			3089802	_____	/m
	<b>Plastic glazing bead NKS 26</b> <b>infill thickness 26 mm or 51 mm</b> (for FP profiles) Length _____ mm (max. 6000 mm)	01.02.2009 – 28.02.2013	3085749	Units _____	/m
	<b>Infill seal, exterior, for NF profiles,</b> <b>HG 009</b> Length _____ mm	09.07.2001 – 28.02.2013	3045678	Units _____	/m
	<b>Infill seal, exterior, for WF profiles,</b> <b>HG 007</b> Length _____ mm	09.07.2001 – 28.02.2013	3045679	Units _____	/m

+<sup>2</sup> Surcharge for infills in preferred colour and RAL to choose, see page 136 / indicate RAL colour article number.

<b>ORDER</b>	Customer no.:	Order no./com.:	<b>*Please take information from the data label!</b>	
			Order no.:	Door no.:
	Customer name:		Product no.:	Type:
	Shipping address:	Year of manufacture:		
	Place/date:	Stamp and signature		

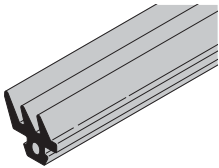
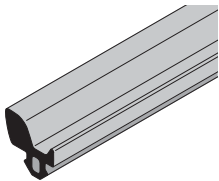
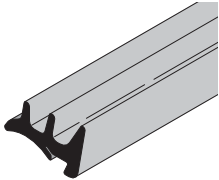
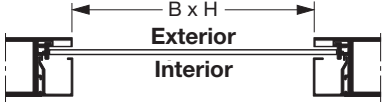
# 4. Accessories for Door Sections

Article	Description	Production period	Art. no.	Qty.	€
	<b>Infill seal, exterior, for 3 mm Synthetic pane clear / crystal and 6 mm Polycarbonate pane</b> Length _____ mm	09.07.2001 – 28.02.2013	3092161	Units _____	/m
	<b>Infill seal, exterior, for FP profiles</b> Length _____ mm	01.02.2009 – 28.02.2013	3082231	Units _____	/m
	<b>* Triangular seal, interior</b> for 16 mm infill (no real glass) or expanded mesh, HG 008 Length _____ mm	09.07.2001 – 28.02.2013	3045680	Units _____	/m
	for 26 mm infill (no real glass), Rahmen aus Normalprofilen / frame made of thermal break profiles, HG 019 Length _____ mm	09.07.2001 – 28.02.2013	3061831	Units _____	/m
	for VG and ES, NF / WF-Profile, HG 046 Length _____ mm	01.03.2004 – 28.02.2013	3062860	Units _____	/m
	for E2 and G2, HG 062 Length _____ mm	01.07.2011 – 28.02.2013	3091314	Units _____	/m
	for FP profiles HG 049 Length _____ mm	01.07.2009 – 28.02.2013	3091578	Units _____	/m
 	<b>* Indicate clear view:</b> B _____ mm x H _____ mm			Units	
	<b>Synthetic pane, single, clear, 3 mm, FK</b>	09.07.2001 – 28.02.2013	3095225	_____	/each
	<b>Polycarbonate pane, single, clear, 6 mm, P</b>	09.07.2001 – 28.02.2013	3095228	_____	/each
	<b>Single pane of clear laminated safety glass, 6 mm, VG</b>	01.03.2004 – 28.02.2013	3062079	_____	/m <sup>2</sup>

+2 Surcharge for infills in preferred colour and RAL to choose, see page 136 / indicate RAL colour article number.

<b>ORDER</b>	Customer no.: _____	Order no./com.: _____	<b>*Please take information from the data label!</b>	
			Order no.:	Door no.:
	Customer name: _____		Product no.:	Type:
	Shipping address: _____		Year of manufacture:	
	Place/date: _____		Stamp and signature	

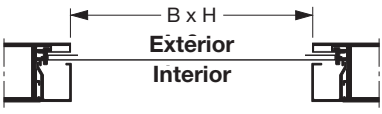
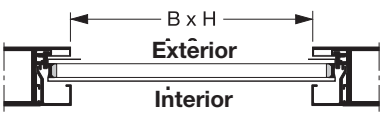
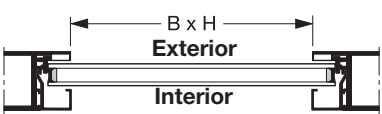

# 4. Accessories for Door Sections

Article	Description	Production period	Art. no.	Qty.	€
*	 <p>Indicate clear view: B _____ mm x H _____ mm</p> <p><b>Synthetic pane, single, crystal structure, 3 mm, KR</b></p>	09.07.2001 – 04.04.2007 05.04.2007 – 28.02.2013	3095226 3095227	Units _____ _____	/each /each
	 <p>Indicate clear view: B _____ mm x H _____ mm</p> <p><b>Double-moulded pane, 16 mm, S</b></p>	13.07.2007 – 28.02.2013	3095232	Units _____	/each
*	 <p>Indicate clear view: B _____ mm x H _____ mm</p> <p><b>Clear synthetic double pane</b> 16 mm, DS 26 mm, S2</p> <p><b>Polycarbonate double pane, clear</b> 16 mm, PD 26 mm, C2</p> <p><b>Double pane made of single-pane safety glass, clear</b> 16 mm, ES 26 mm, E2 26 mm, G2</p>	09.07.2001 – 30.06.2009 01.07.2009 – 28.02.2013 09.07.2001 – 30.06.2009 01.07.2009 – 28.02.2013 01.03.2004 – 30.06.2011 01.07.2011 – 28.02.2013 01.07.2011 – 28.02.2013	3095239 3095243 3095242 3095249 3062080 3090382 3090527	Units _____ _____ _____ _____ _____ _____ _____	/each /each /each /each /m <sup>2</sup> /m <sup>2</sup> /m <sup>2</sup>

+<sup>2</sup> Surcharge for infills in preferred colour and RAL to choose, see page 136 / indicate RAL colour article number.

<b>ORDER</b>	Customer no.: _____	Order no./com.: _____	<b>*Please take information from the data label!</b>	
			Order no.:	Door no.:
	Customer name: _____		Product no.:	Type:
	Shipping address: _____		Year of manufacture:	
	Place/date: _____		Stamp and signature	

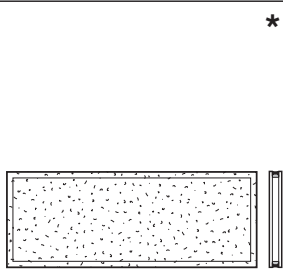
# 4. Accessories for Door Sections

Article	Description	Production period	Art. no.	Qty.	€
	<p><b>*</b></p> <p>Indicate clear view:            B _____ mm x            H _____ mm</p> <p><b>Synthetic double pane, crystal structure</b></p>			Units	
	16 mm, DK	09.07.2001 – 04.04.2007	3095240	_____	/each
	16 mm, DK	05.04.2007 – 30.06.2009	3095241	_____	/each
	26 mm, R2	01.07.2009 – 28.02.2013	3095244	_____	/each
	<p><b>*</b></p> <p>Indicate clear view:            B _____ mm x            H _____ mm</p> <p><b>Synthetic triple pane, clear, 26 mm, S3</b></p>			Units	
		01.07.2009 – 28.02.2013	3095250	_____	/each
	<p><b>*</b></p> <p>Indicate clear view:            B _____ mm x            H _____ mm</p> <p><b>DPU synthetic pane, depth 80, clear, 45 mm</b></p>			Units	
	K2 double pane	01.01.2007 – 28.02.2013	3095256	_____	/each
	K3 triple pane	01.01.2007 – 28.02.2013	3095257	_____	/each
	K4 quadruple pane	01.01.2007 – 28.02.2013	3095258	_____	/each

+2 Surcharge for infills in preferred colour and RAL to choose, see page 136 / indicate RAL colour article number.

<b>ORDER</b>	Customer no.: _____	Order no./com.: _____	<b>*Please take information from the data label!</b>	
			Order no.:	Door no.:
	Customer name: _____		Product no.:	Type:
	Shipping address: _____		Year of manufacture:	
	Place/date: _____		Stamp and signature	



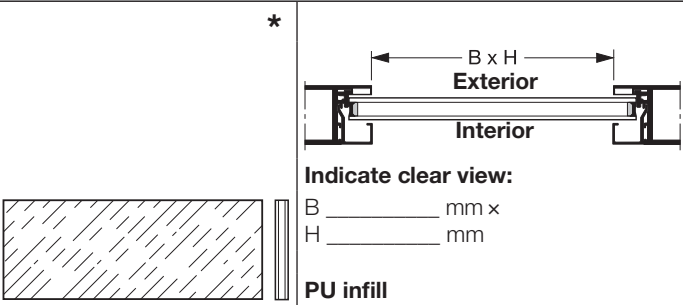
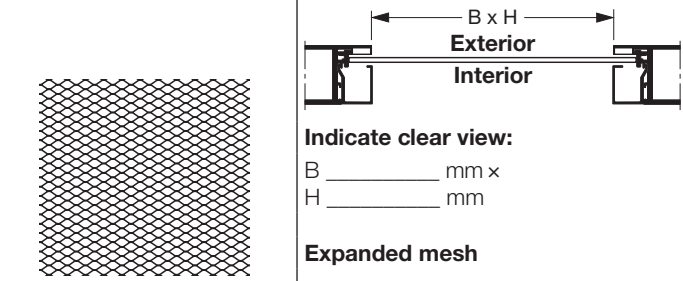
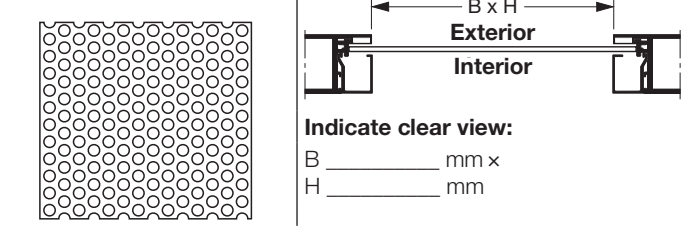
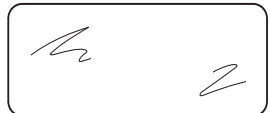

# 4. Accessories for Door Sections

Article	Description	Production period	Art. no.	Qty.	€
*	 <p><b>Indicate clear view:</b> B _____ mm x H _____ mm</p> <p><b>PU infill</b></p> <p>16 mm, Stucco-textured, PU 16 mm, anodised aluminium, smooth, EU 26 mm, anodised aluminium, smooth, XU 26 mm, Stucco-textured, FU Based on RAL _____</p>	09.07.2001 – 30.06.2009 09.07.2001 – 30.06.2009 01.07.2009 – 28.02.2013 09.07.2001 – 28.02.2013	3095234 3095233 3095235 3095236	Units _____ _____ _____ _____	 /each /each /each /each + <sup>2</sup>
	 <p><b>Indicate clear view:</b> B _____ mm x H _____ mm</p> <p><b>Expanded mesh</b></p> <p>Stainless steel, SE Wet coated, SG Based on RAL _____</p>	01.08.2010 – 28.02.2013 09.07.2001 – 31.07.2010	3095230 3095229	Units _____ _____	 /each /each + <sup>2</sup>
	 <p><b>Indicate clear view:</b> B _____ mm x H _____ mm</p> <p><b>Perforated stainless steel sheet, LB, perforation 8 mm</b></p>	09.07.2001 – 28.02.2013	3095231	Units _____	 /each
	 <p><b>Synthetic pane, single, clear, for vision panel type A, 3 mm</b></p>	09.07.2001 – 29.02.2008	3056315	Units _____	 /each

+<sup>2</sup> Surcharge for infills in preferred colour and RAL to choose, see page 136 / indicate RAL colour article number.

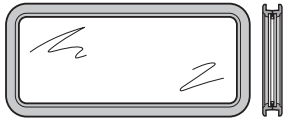
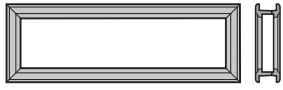
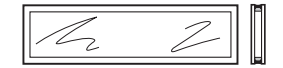
<b>ORDER</b>	Customer no.:	Order no./com.:	<b>*Please take information from the data label!</b>	
	Customer name:		Order no.:	Door no.:
	Shipping address:		Product no.:	Type:
			Year of manufacture:	
	Place/date:	Stamp and signature		

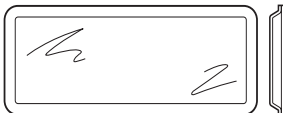
# 4. Accessories for Door Sections





Article	Description	Production period	Art. no.	Qty.	€
	<b>Compound glazing type A, for double-skinned door sections 42 / 20 mm, plastic frame with synthetic double pane, clear, 11 mm</b>	09.07.2001 – 23.02.2006	3057713	Units _____	/each
	<b>Frame type D, for double-skinned door sections 42 / 20 mm, black</b>	09.07.2001 – 23.02.2006	3065218	Units _____	/each
	<b>Synthetic double pane, clear / clear, for glazing type D, 16 mm</b>	09.07.2001 – 28.02.2013	3092754	Units _____	/each
	<b>Compound glazing type E, for double-skinned door sections 42 / 20 mm, plastic frame with synthetic double pane, clear, 11 mm</b>	09.07.2001 – 23.02.2006	3057717	Units _____	/each
	<b>Diecast frame for compound glazing type A, based on RAL 9011, for double-skinned door sections 42 mm</b>  For ribbed doors For non-ribbed doors	01.03.2012 – 28.02.2013	3091301	Units _____	/each
		01.03.2012 – 28.02.2013	3091302	Units _____	/each
	<b>Synthetic double pane, clear, for compound glazing type A</b>  29 mm 26 mm 29 mm, Polycarbonate 26 mm, Polycarbonate	09.07.2001 – 29.02.2012	3089760	Units _____	/each
		01.03.2012 – 28.02.2013	3090821	Units _____	/each
		09.07.2001 – 29.09.2012	3089762	Units _____	/each
		01.03.2012 – 28.02.2013	3090823	Units _____	/each
	<b>Compound glazing type A, for double-skinned door sections 42 mm, plastic frame with synthetic double pane, clear, 33 mm</b>  For ribbed doors For non-ribbed doors	09.07.2001 – 28.02.2013	3057711	Units _____	/each
		01.02.2009 – 28.02.2013	3057712	Units _____	/each

+2 Surcharge for infills in preferred colour and RAL to choose, see page 136 / indicate RAL colour article number.

<b>ORDER</b>	Customer no.:	Order no./com.:	<b>*Please take information from the data label!</b>	
			Order no.:	Door no.:
	Customer name:		Product no.:	Type:
	Shipping address:		Year of manufacture:	
	Place/date:		Stamp and signature	

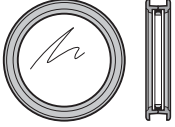
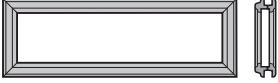
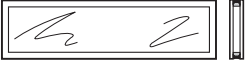

# 4. Accessories for Door Sections

Article	Description	Production period	Art. no.	Qty.	€
	<b>Compound glazing type C, for double-skinned door sections 42 mm, plastic frame with synthetic double pane, clear, 31 mm</b>	09.07.2001 – 31.01.2009	3047150	Units _____	/each
	<b>Plastic frame type D, for double-skinned door sections 42 mm, black</b>  For ribbed doors For non-ribbed doors	09.07.2001 – 28.02.2013 01.02.2009 – 28.02.2013	3065217 3086141	Units _____ _____	/each /each
	<b>Synthetic double pane, clear / clear, for glazing type D</b>	09.07.2001 – 28.02.2013	3092754	Units _____	/each
	<b>Compound glazing type E, for double-skinned door sections 42 mm, plastic frame with synthetic double pane, clear, 33 mm</b>  For ribbed doors For non-ribbed doors	09.07.2001 – 28.02.2013 01.02.2009 – 28.02.2013	3057715 3057716	Units _____ _____	/each /each
	<b>Diecast frame for compound glazing type A, for double-skinned door sections 80 mm Based on RAL 9011</b>	08.03.2012 – 28.02.2013	3091312	Units _____	/each
	<b>Synthetic double pane, clear, for compound glazing type A, for double-skinned door sections 80 mm</b>  43 mm 64 mm	01.10.2005 – 07.03.2012 08.03.2012 – 28.02.2013	3089753 3090838	Units _____ _____	/each /each

+<sup>2</sup> Surcharge for infills in preferred colour and RAL to choose, see page 136 / indicate RAL colour article number.

<b>ORDER</b>	Customer no.: _____	Order no./com.: _____	<b>*Please take information from the data label!</b>	
			Order no.: _____	Door no.: _____
	Customer name: _____		Product no.: _____	Type: _____
	Shipping address: _____		Year of manufacture: _____	
	Place/date: _____		Stamp and signature _____	

# 4. Accessories for Door Sections

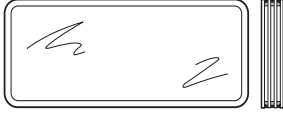
Article	Description	Production period	Art. no.	Qty.	€
	<b>Synthetic triple pane, clear, for compound glazing type A, for double-skinned door sections 80 mm</b>  43 mm 64 mm	01.10.2005 – 07.03.2012 08.03.2012 – 28.02.2013	3089754 3090839	Units	
				_____	/each
	<b>Synthetic quadruple pane, clear, for compound glazing type A, for double-skinned door sections 80 mm</b>  43 mm 64 mm	01.10.2005 – 07.03.2012 08.03.2012 – 28.02.2013	3089755 3090840	Units	
				_____	/each

+<sup>2</sup> Surcharge for infills in preferred colour and RAL to choose, see page 136 / indicate RAL colour article number.

<b>ORDER</b>	Customer no.: _____	Order no./com.: _____	<b>*Please take information from the data label!</b>	
	Customer name: _____	Product no.: _____	Order no.: _____	Door no.: _____
	Shipping address: _____	Year of manufacture: _____		
	Place/date: _____	Stamp and signature _____		

# 4. Accessories for Door Sections

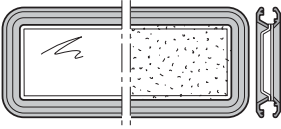
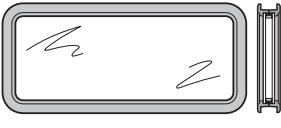
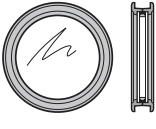
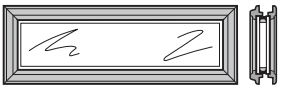
Article	Description	Production period	Art. no.	Qty.	€
	<b>Complete compound glazing</b> <b>Type A, for double-skinned door sections 42 mm, diecast frame based on RAL 9011, synthetic double pane, clear</b>			Units	
	For ribbed doors	09.07.2001 – 28.02.2013	3091303	_____	/each
	For non-ribbed doors	01.02.2009 – 28.02.2013	3091304	_____	/each
	<b>Polycarbonate / synthetic double pane, clear</b>				
	For ribbed doors	09.07.2001 – 28.02.2013	3091305	_____	/each
	For non-ribbed doors	01.02.2009 – 28.02.2013	3091306	_____	/each
	<b>Complete compound glazing</b> <b>Type A, for double-skinned door sections 42 mm, plastic frame, synthetic double pane, clear</b>				
	For ribbed doors	09.07.2001 – 28.02.2013	3057711	_____	/each
	For non-ribbed doors	01.02.2009 – 28.02.2013	3057712	_____	/each
	<b>Complete compound glazing</b> <b>Type C, for double-skinned door sections 42 mm, plastic frame, synthetic double pane, clear</b>	01.07.2001 – 31.01.2009	3047150	_____	/each
	<b>Complete compound glazing</b> <b>Type D, for double-skinned door sections 42 mm, plastic frame, synthetic double pane, clear</b>				
	For ribbed doors	09.07.2001 – 28.02.2013	3087587	_____	/each
	For non-ribbed doors	01.02.2009 – 28.02.2013	3087588	_____	/each

+<sup>2</sup> Surcharge for infills in preferred colour and RAL to choose, see page 136 / indicate RAL colour article number.

<b>ORDER</b>	Customer no.:	Order no./com.:	<b>*Please take information from the data label!</b>	
			Order no.:	Door no.:
	Customer name:		Product no.:	Type:
	Shipping address:	Year of manufacture:		
	Place/date:	Stamp and signature		

## 4. Accessories for Door Sections

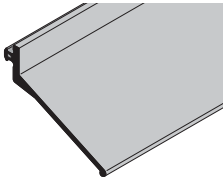
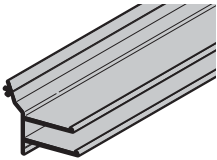
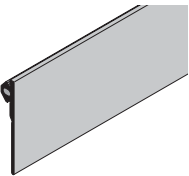
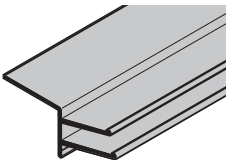
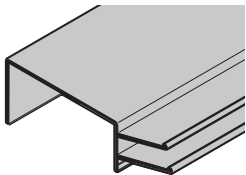
Article	Description	Production period	Art. no.	Qty.	€
	<b>Complete compound glazing</b> <b>Type E, for double-skinned door sections 42 mm, plastic frame, synthetic double pane, clear</b> For ribbed doors For non-ribbed doors	09.07.2001 – 28.02.2013 01.02.2009 – 28.02.2013	3057715 3057716	Units _____ _____	/each /each
	<b>Complete compound glazing</b> <b>Type A, for double-skinned door sections 80 mm, diecast frame based on RAL 9011</b> With synthetic double pane, clear With synthetic triple pane, clear With synthetic quadruple pane, clear	01.10.2005 – 28.02.2013 01.10.2005 – 28.02.2013 01.10.2005 – 28.02.2013	3091309 3091310 3091311	_____ _____ _____	/each /each /each
	<b>Lintel seal HG 004</b> Length _____ mm	09.07.2001 – 28.02.2013	3045681	Units _____	/m
	<b>Lintel seal ThermoFrame HG 057</b> Length _____ mm (max. 8000 mm)	01.05.2011 – 28.02.2013	3090368	Units _____	/m
	<b>Lintel seal ASR / ASP / HG 051</b> Length _____ mm	01.02.2009 – 28.02.2013	3082232	Units _____	/m
	<b>Lintel profile ThermoFrame, ASR / ASP / HG 061</b> Length _____ mm (max. 10050 mm)	01.05.2011 – 28.02.2013	3090370	Units _____	/m
	<b>Lintel profile depth 80 / HG 060</b> Length _____ mm (max. 10050 mm)	01.05.2011 – 28.02.2013	3090369	Units _____	/m

+2 Surcharge for infills in preferred colour and RAL to choose, see page 136 / indicate RAL colour article number.

<b>ORDER</b>	Customer no.:	Order no./com.:	<b>*Please take information from the data label!</b>	
	Customer name:	Product no.:		Door no.:
	Shipping address:	Year of manufacture:		
	Place/date:	Stamp and signature		

## 4. Accessories for Door Sections

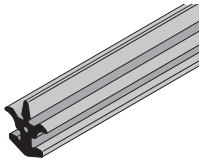
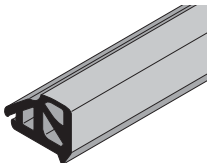
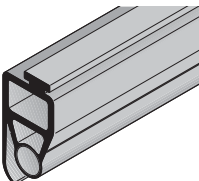
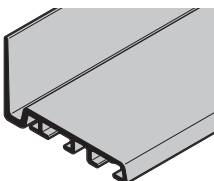
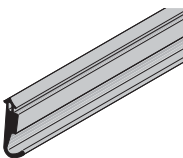
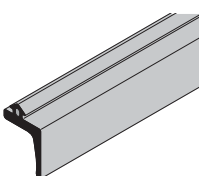
Article	Description	Production period	Art. no.	Qty.	€
	<b>NF intermediate seal / HG 016</b> Length _____ mm	09.07.2001 – 28.02.2013	3045684	Units _____	/m
	<b>WF intermediate seal / HG 013</b> Length _____ mm	09.07.2001 – 28.02.2013	3045685	Units _____	/m
	<b>Bottom seal HG 033</b> Length _____ mm	09.07.2001 – 28.02.2013	3064443	Units _____	/m
	<b>Rail holder for floor seal</b> Length _____ mm Drilling screw 3.5 × 9.5 galvanized	09.07.2001 – 28.02.2013	3041117 3041298	Units _____ _____	/m /each
	<b>Bottom profile depth 80</b> Length _____ mm (max. 10050 mm)	01.02.2011 – 28.02.2013	3090371	Units _____	/m
	<b>Door seal, side / HG 014</b> Length _____ mm	01.07.2001 – 28.02.2013	3046482	Units _____	/m
	<b>Threshold seal for wicket door with tripping threshold / HG 040</b> Length _____ mm	02.01.2005 – 28.02.2013	3070039	Units _____	/m
	<b>Door seal, bottom, for wicket door with trip-free threshold / HG 039</b> Length _____ mm	01.05.2005 – 28.02.2013	3064281	Units _____	/m

+<sup>2</sup> Surcharge for infills in preferred colour and RAL to choose, see page 136 / indicate RAL colour article number.

<b>ORDER</b>	Customer no.: _____	Order no./com.: _____	<b>*Please take information from the data label!</b>	
	Customer name: _____	Shipping address: _____	Order no.: _____	Door no.: _____
	Place/date: _____	Stamp and signature _____	Product no.: _____	Type: _____
			Year of manufacture: _____	

## 4. Accessories for Door Sections

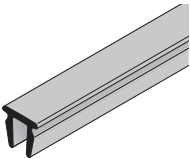
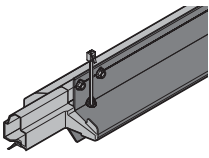
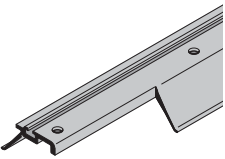
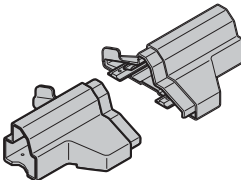
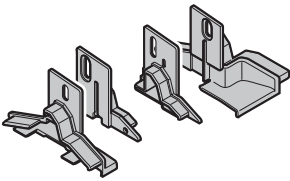
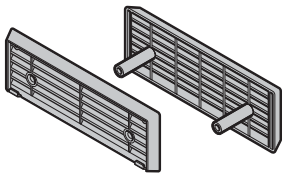
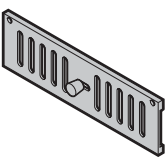
Article	Description	Production period	Art. no.	Qty.	€
	<b>Threshold seal, bottom, for wicket door with trip-free threshold</b> Length _____ mm	01.05.2005 – 28.02.2013	3064282	Units _____	/m
	<b>* Threshold profile with floor seal and bottom section end piece</b> 120 mm, up to door widths of 5500 mm 140 mm, from door widths of 5510 mm	01.05.2005 – 28.02.2013 02.11.2005 – 28.02.2013	3090372 3090374	Units _____ _____	/m /m
	<b>* Perforated bottom seal for doors with wicket doors / HG 044</b> Length _____ mm Self-tapping screw 4.2 x 13, with tallow-drop Torx head, stainless steel	01.05.2005 – 28.02.2013	3064283 3065933	Units _____ _____	/m /each
	<b>Set: Bottom section end piece for doors with wicket doors with trip-free thresholds</b>	01.05.2005 – 28.02.2013	3093358	Units _____	/each
	<b>Set: Bottom door section caps and end caps for doors with wicket doors with trip-free thresholds</b> Right-hand hinged Left-hand hinged	01.05.2005 – 28.02.2013 01.05.2005 – 28.02.2013	3064284 3064285	Units _____ _____	/each /each
	<b>Ventilation grille</b> (0.75 – 1.5 mm) for STE, ALR 40 (16 mm) for ALR, TAR 40 (20 mm) for TPU 40 (26 mm) for ALR, TAR 40 (42 mm) for SPU, APU, TAP 40	09.07.2001 – 28.02.2013 09.07.2001 – 28.02.2013 09.07.2001 – 23.02.2006 09.07.2001 – 28.02.2013 09.07.2001 – 28.02.2013	3041096 3041094 3055464 3046722 3041072	Units _____ _____ _____ _____ _____	/each /each /each /each /each
	<b>Sliding cover</b>	09.07.2001 – 28.02.2013	3021556	Units _____	/each

+2 Surcharge for infills in preferred colour and RAL to choose, see page 136 / indicate RAL colour article number.

<b>ORDER</b>	Customer no.:	Order no./com.:	<b>*Please take information from the data label!</b>	
			Order no.:	Door no.:
	Customer name:		Product no.:	Type:
	Shipping address:		Year of manufacture:	
	Place/date:		Stamp and signature	

# 5. Fitting Parts for Door Sections

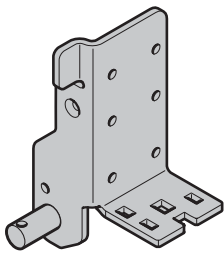
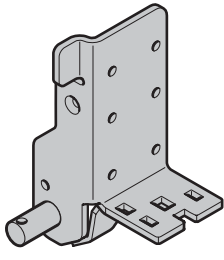
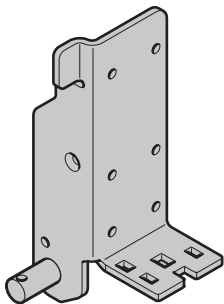
Article	Description	Production period	Art. no.	Qty.	€
	<p><b>* Bottom cable bracket</b>  <b>Track application N, ND, NS, NB, L, LD</b>            Up to 400 kg door leaf weight</p>			Units	
	<p><b>Right</b>, galvanized</p>	09.07.2001 – 28.02.2013	3040503	_____	/each
	<p><b>Left</b>, galvanized</p>	09.07.2001 – 28.02.2013	3040504	_____	/each
	<p>Self-tapping screw A 6.5 × 20, dacromet</p>		3042487	_____	/each
	<p><b>Right</b>, stainless steel</p>	09.07.2001 – 28.02.2013	3072267	_____	/each
	<p><b>Left</b>, stainless steel</p>	09.07.2001 – 28.02.2013	3072268	_____	/each
	<p>Self-tapping screw A 6.5 × 19, stainless steel</p>		3091361	_____	/each
	<p><b>* Reinforced bottom cable bracket</b>  <b>Track application N, ND, NS, NB, L, LD</b>            From 401 kg door leaf weight</p>			Units	
	<p><b>Right</b>, galvanized</p>	09.07.2001 – 28.02.2013	3044676	_____	/each
	<p><b>Left</b>, galvanized</p>	09.07.2001 – 28.02.2013	3044677	_____	/each
	<p>Self-tapping screw A 6.5 × 20, dacromet</p>		3042487	_____	/each
	<p><b>Right</b>, stainless steel</p>	09.07.2001 – 28.02.2013	3072269	_____	/each
	<p><b>Left</b>, stainless steel</p>	09.07.2001 – 28.02.2013	3072270	_____	/each
	<p>Self-tapping screw A 6.5 × 19, stainless steel</p>		3091361	_____	/each
	<p><b>* Bottom cable bracket</b>  <b>Track application H, HD, HS, HU, HB, V, VU, VS, VB, NH</b>            Up to 400 kg door leaf weight</p>			Units	
	<p><b>Right</b>, galvanized</p>	09.07.2001 – 28.02.2013	3040793	_____	/each
	<p><b>Left</b>, galvanized</p>	09.07.2001 – 28.02.2013	3040794	_____	/each
	<p>Self-tapping screw A 6.5 × 20, dacromet</p>		3042487	_____	/each
	<p><b>Right</b>, stainless steel</p>	09.07.2001 – 28.02.2013	3072271	_____	/each
	<p><b>Left</b>, stainless steel</p>	09.07.2001 – 28.02.2013	3072272	_____	/each
	<p>Self-tapping screw A 6.5 × 19, stainless steel</p>		3091361	_____	/each

<b>ORDER</b>	Customer no.: _____	Order no./com.: _____	<b>*Please take information from the data label!</b>	
			Order no.:	Door no.:
	Customer name: _____		Product no.:	Type:
	Shipping address: _____		Year of manufacture:	
	Place/date: _____		Stamp and signature	

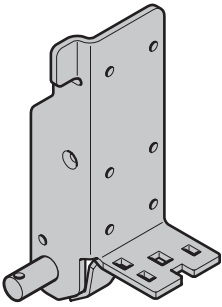
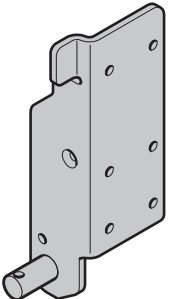
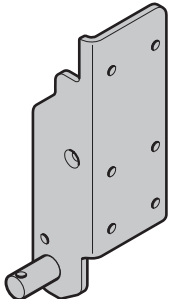
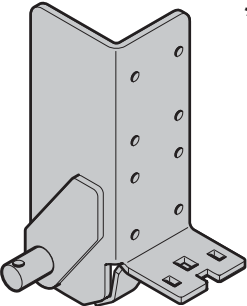

## 5. Fitting Parts for Door Sections

Article	Description	Production period	Art. no.	Qty.	€
	<p><b>* Reinforced bottom cable bracket</b>  <b>Track application H, HD, HS, HU, HB, V, VU, VS, VB, NH</b>            From 401 kg door leaf weight</p>			Units	
	<p><b>Right</b>, galvanized</p>	09.07.2001 – 28.02.2013	3044684	_____	/each
	<p><b>Left</b>, galvanized</p>	09.07.2001 – 28.02.2013	3044685	_____	/each
	<p>Self-tapping screw A 6.5 × 20, dacromet</p>		3042487	_____	/each
	<p><b>Right</b>, stainless steel</p>	09.07.2001 – 28.02.2013	3072273	_____	/each
<p><b>Left</b>, stainless steel</p>	09.07.2001 – 28.02.2013	3072274	_____	/each	
	<p>Self-tapping screw A 6.5 × 19, stainless steel</p>		3091361	_____	/each
	<p><b>* Bottom cable bracket type S (HV2)</b>  <b>Track application HG, RG, WG, KG, TG, MG</b></p>			Units	
	<p><b>Right</b>, galvanized</p>	01.07.2005 – 28.02.2013	3065275	_____	/each
	<p><b>Left</b>, galvanized</p>	01.07.2005 – 28.02.2013	3065276	_____	/each
	<p>Self-tapping screw A 6.5 × 20, dacromet</p>		3042487	_____	/each
	<p><b>* Bottom cable bracket type S (HV3)</b>  <b>Track application HG, RG, WG, KG, TG, MG</b></p>			Units	
	<p><b>Right</b>, galvanized</p>	01.07.2005 – 28.02.2013	3089806	_____	/each
	<p><b>Left</b>, galvanized</p>	01.07.2005 – 28.02.2013	3089805	_____	/each
	<p>Self-tapping screw A 6.5 × 20, dacromet</p>		3042487	_____	/each
	<p><b>* Reinforced bottom cable bracket</b>  <b>For depth 80 with direct drive operator</b></p>			Units	
	<p><b>Right</b>, galvanized</p>	01.07.2005 – 28.02.2013	3065270	_____	/each
	<p><b>Left</b>, galvanized</p>	01.07.2005 – 28.02.2013	3065269	_____	/each
	<p>Self-tapping screw A 6.5 × 75, dacromet</p>		3062892	_____	/each

<b>ORDER</b>	Customer no.:	Order no./com.:	<b>*Please take information from the data label!</b>	
			Order no.:	Door no.:
	Customer name:		Product no.:	Type:
	Shipping address:		Year of manufacture:	
	Place/date:		Stamp and signature	

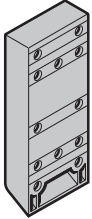

# 5. Fitting Parts for Door Sections

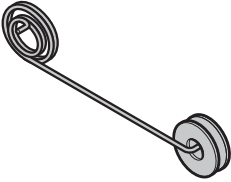
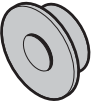
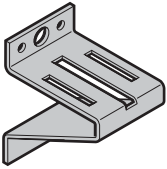
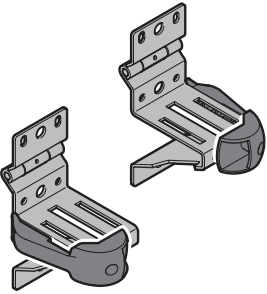
Article	Description	Production period	Art. no.	Qty.	€
	<b>Support for bottom cable bracket</b> For TPU 40	09.07.2001 – 23.02.2006	3054868	Units _____	/each
	<b>Spacer ring and locking ring for cable holder bolts (1 = pair)</b>	09.07.2001 – 28.02.2013	3046587	Units _____	/each
	<b>Leg spring</b>			Units	
	Right Left	09.07.2001 – 28.02.2013 09.07.2001 – 28.02.2013	3055306 3055307	_____ _____	/each /each
	<b>Holder for leg spring</b>	09.07.2001 – 28.02.2013	3055304	Units _____	/each
	<b>Roller bracket</b>			Units	
	Top, galvanized Self-tapping screw A 6.5 x 20, dacromet	09.07.2001 – 28.02.2013	3093585	_____	/each
			3042487	_____	/each
	Top, stainless steel Self-tapping screw A 6.5 x 19, stainless steel	09.07.2001 – 28.02.2013	3093586	_____	/each
			3091361	_____	/each
	<b>Roller bracket type 6, HU / VU with cable guard</b>			Units	
	Galvanized Self-tapping screw A 6.5 x 20, dacromet	09.07.2001 – 28.02.2013	3095192	_____	/each
			3042487	_____	/each
	Stainless steel Self-tapping screw A 6.5 x 19, stainless steel	09.07.2001 – 28.02.2013	3095193	_____	/each
			3091361	_____	/each

<b>ORDER</b>	Customer no.: _____	Order no./com.: _____	<b>*Please take information from the data label!</b>	
			<b>Order no.:</b> _____	<b>Door no.:</b> _____
	Customer name: _____		<b>Product no.:</b> _____	<b>Type:</b> _____
	Shipping address: _____		<b>Year of manufacture:</b> _____	
	Place/date: _____		Stamp and signature _____	

## 5. Fitting Parts for Door Sections

Article	Description	Production period	Art. no.	Qty.	€
	<b>Roller bracket Typ 6, FP for HU/VU</b>			Units	
	Galvanized Self-tapping screw A 6.5 × 20, dacromet	01.03.2013 – 28.02.2013	3091372	_____	/each
			3042487	_____	/each
	Stainless steel Self-tapping screw A 6.5 × 19, stainless steel	01.03.2013 – 28.02.2013	3091373	_____	/each
			3091361	_____	/each
	Roller bracket spacer plate	01.03.2013 – 28.02.2013	3080123	_____	/each
	<b>Roller bracket type 6</b>			Units	
	Galvanized For wicket door with trip-free threshold from door widths of 5510 mm, galvanized	09.07.2001 – 28.02.2013	3093587	_____	/each
		02.11.2005 – 28.02.2013	3093589	_____	/each
	Self-tapping screw A 6.5 × 20, dacromet		3042487	_____	/each
	Stainless steel For wicket door with trip-free threshold from door widths of 5510 mm, stainless steel	09.07.2001 – 28.02.2013	3093588	_____	/each
	02.11.2005 – 28.02.2013	3093590	_____	/each	
	Self-tapping screw A 6.5 × 19, stainless steel		3091361	_____	/each
	<b>Cable guard for HU/VU</b> (for 4 roller brackets)	01.04.2015 –	3093857	Units _____	/each
	<b>Roller bracket type 6 FP</b>			Units	
	Galvanized Self-tapping screw A 6.5 × 20, dacromet	01.02.2009 – 28.02.2013	3080083	_____	/each
			3042487	_____	/each
	Stainless steel Self-tapping screw A 6.5 × 19, stainless steel	01.02.2009 – 28.02.2013	3080084	_____	/each
			3091361	_____	/each
	Roller bracket spacer plate	01.02.2009 – 28.02.2013	3080123	_____	/each

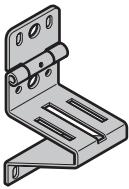

<b>ORDER</b>	Customer no.:	Order no./com.:	<b>*Please take information from the data label!</b>	
			Order no.:	Door no.:
	Customer name:		Product no.:	Type:
	Shipping address:	Year of manufacture:		
	Place/date:	Stamp and signature		

## 5. Fitting Parts for Door Sections

Article	Description	Production period	Art. no.	Qty.	€
	<b>Roller bracket support</b>			Units	
	<b>Right</b> , galvanized	09.07.2001 – 28.02.2013	3041156	_____	/each
	<b>Left</b> , galvanized	09.07.2001 – 28.02.2013	3041157	_____	/each
	Self-tapping screw A 6.5 × 16, dacromet		3040982	_____	/each
	Round-head screw M6 × 16, galvanized		3001431	_____	/each
	Hex nut M6, self-locking with flange, galvanized		3001660	_____	/each
	<b>Right</b> , stainless steel	09.07.2001 – 28.02.2013	3043323	_____	/each
	<b>Left</b> , stainless steel	09.07.2001 – 28.02.2013	3043322	_____	/each
	Self-tapping screw A 6.5 × 16, stainless steel		3091360	_____	/each
	Round-head screw M6 × 14, stainless steel		3073210	_____	/each
	Hex nut M6, self-locking with flange, stainless steel		3054418	_____	/each
		<b>Roller bracket, depth 80</b>			Units
Galvanized		01.10.2005 – 28.02.2013	3062244	_____	/each
Stainless steel		01.10.2005 – 28.02.2013	3089780	_____	/each
Self-tapping screw A 6.5 × 75, dacromet			3062892	_____	/each
	<b>Roller bracket support, depth 80</b>			Units	
	<b>Right</b> , galvanized	01.10.2005 – 28.02.2013	3072435	_____	/each
	<b>Left</b> , galvanized	01.10.2005 – 28.02.2013	3072434	_____	/each
	Self-tapping screw A 6.5 × 75, dacromet		3062892	_____	/each
	Round-head screw M6 × 16, galvanized		3001431	_____	/each
	Hex nut M6, self-locking with flange, galvanized		3001660	_____	/each
	<b>Right</b> , stainless steel	01.10.2005 – 28.02.2013	3089783	_____	/each
	<b>Left</b> , stainless steel	01.10.2005 – 28.02.2013	3089782	_____	/each
	Self-tapping screw A 6.5 × 16, dacromet		3062892	_____	/each
	Round-head screw M6 × 14, stainless steel		3073210	_____	/each
	Hex nut M6, self-locking with flange, stainless steel		3054418	_____	/each

<b>ORDER</b>	Customer no.: _____	Order no./com.: _____	<b>*Please take information from the data label!</b>	
			<b>Order no.:</b> _____	<b>Door no.:</b> _____
	Customer name: _____		<b>Product no.:</b> _____	<b>Type:</b> _____
	Shipping address: _____		<b>Year of manufacture:</b> _____	
	Place/date: _____		Stamp and signature _____	

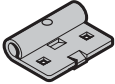
## 5. Fitting Parts for Door Sections

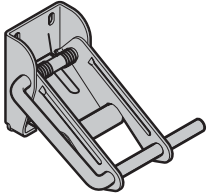
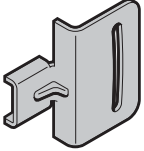
Article	Description	Production period	Art. no.	Qty.	€
	<b>Roller holders</b>			Units	
	Galvanized	09.07.2001 – 28.02.2013	3039948	_____	/each
	Reinforced, galvanized	09.07.2001 – 28.02.2013	3054772	_____	/each
	Depth 80, reinforced, galvanized	01.06.2006 – 28.02.2013	3062262	_____	/each
	Depth 80, wide version, galvanized	01.06.2006 – 28.02.2013	3065327	_____	/each
	Round-head screw M6 × 14, galvanized		3086084	_____	/each
	Hex nut M6, self-locking with flange, galvanized		3001660	_____	/each
	Stainless steel	09.07.2001 – 28.02.2013	3040124	_____	/each
	Reinforced, stainless steel	09.07.2001 – 28.02.2013	3054797	_____	/each
	Round-head screw M6 × 14, stainless steel		3073210	_____	/each
Hex nut M6, self-locking with flange, stainless steel		3054418	_____	/each	
	<b>Bottom roller holder, type S</b>			Units	
	Galvanized	01.07.2005 – 28.02.2013	3065277	_____	/each
	Self-tapping screw A 6.5 × 20, dacromet		3042487	_____	/each
	<b>Roller holder, type S</b>			Units	
	Galvanized	01.07.2005 – 28.02.2013	3065278	_____	/each
	Self-tapping screw A 6.5 × 20, dacromet		3042487	_____	/each
	<b>Top roller holder</b>			Units	
	<b>Track application N, ND, NS</b>				
	<b>Right</b> , galvanized	09.07.2001 – 28.02.2013	3094454	_____	/each
	<b>Left</b> , galvanized	09.07.2001 – 28.02.2013	3094453	_____	/each
	Self-tapping screw A 6.5 × 20, dacromet		3042487	_____	/each
	<b>Right</b> , stainless steel	09.07.2001 – 28.02.2013	3094456	_____	/each
<b>Left</b> , stainless steel	09.07.2001 – 28.02.2013	3094455	_____	/each	
	Self-tapping screw A 6.5 × 19, stainless steel		3091361	_____	/each
	<b>Buffer bracket</b>			Units	
	<b>Track application N, ND, NS</b>	09.07.2001 – 28.02.2013	3043209	_____	/each
	Flat-head screw M8 × 13		3043106	_____	/each
	Hex nut M8 with hollow flange		3018270	_____	/each

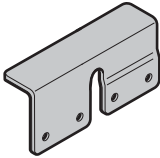
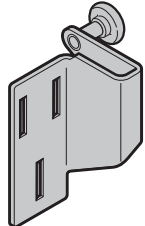
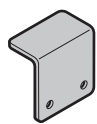
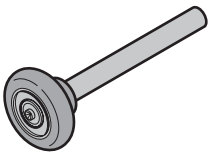
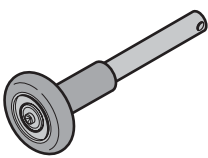
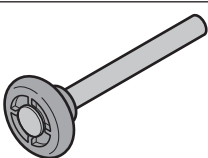

<b>ORDER</b>	Customer no.:	Order no./com.:	<b>*Please take information from the data label!</b>	
			Order no.:	Door no.:
	Customer name:		Product no.:	Type:
	Shipping address:		Year of manufacture:	
	Place/date:		Stamp and signature	

# 5. Fitting Parts for Door Sections

Article	Description	Production period	Art. no.	Qty.	€
	<b>Stop protection 63 x 32 x 122,5</b>			Units	
	<b>Right</b> , galvanized	09.07.2001 – 28.02.2013	3041159	_____	/each
	<b>Left</b> , galvanized	09.07.2001 – 28.02.2013	3041160	_____	/each
	Self-tapping screw A 6.5 x 16, dacromet		3040982	_____	/each
	<b>Right</b> , stainless steel	09.07.2001 – 28.02.2013	3072692	_____	/each
	<b>Left</b> , stainless steel	09.07.2001 – 28.02.2013	3072691	_____	/each
	<b>Top roller holder Track application L, LD</b>			Units	
	<b>Right</b> , galvanized	09.07.2001 – 28.02.2013	3054716	_____	/each
	<b>Left</b> , galvanized	09.07.2001 – 28.02.2013	3054715	_____	/each
	Self-tapping screw A 6.5 x 20, dacromet		3042487	_____	/each
	<b>Right</b> , stainless steel	09.07.2001 – 28.02.2013	3072456	_____	/each
	<b>Left</b> , stainless steel	09.07.2001 – 28.02.2013	3072457	_____	/each
	<b>Stop protection</b>			Units	
	Galvanized	09.07.2001 – 28.02.2013	3041158	_____	/each
	Stainless steel	09.07.2001 – 28.02.2013	3043321	_____	/each
	<b>Roller, type K</b>			Units	
	(ball-bearing)	09.07.2001 – 28.02.2013	3039964	_____	/each
	(ball-bearing), stainless steel	09.07.2001 – 28.02.2013	3053384	_____	/each
	<b>Roller (ball-bearing and cotter pin hole)</b>			Units	
	Type KS, galvanized	09.07.2001 – 28.02.2013	3040122	_____	/each
	Type KS, stainless steel	09.07.2001 – 28.02.2013	3053385	_____	/each
	Type KS-14 for depth 80 with direct drive operator	01.06.2006 – 28.02.2013	3065807	_____	/each
	Cotter pin 4 x 18, galvanized		3024784	_____	/each
	Cotter pin 4 x 18, stainless steel		3090233	_____	/each
	<b>Roller type G (sliding bearing)</b>	09.07.2001 – 28.02.2013	3041112	Units	/each

<b>ORDER</b>	Customer no.:	Order no./com.:	<b>*Please take information from the data label!</b>	
			Order no.:	Door no.:
	Customer name:		Product no.:	Type:
	Shipping address:	Year of manufacture:		
	Place/date:	Stamp and signature		

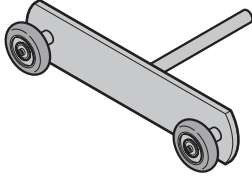
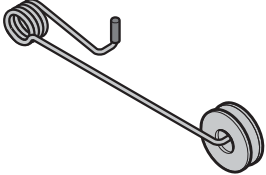
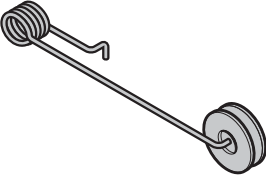
## 5. Fitting Parts for Door Sections

Article	Description	Production period	Art. no.	Qty.	€
	<b>Roller type GS (sliding bearing and cotter pin hole)</b> Cotter pin 4 x 18	09.07.2001 – 28.02.2013	3041113 3024784	Units _____ _____	/each /each
	<b>Spacer ring for roller</b>	09.07.2001 – 28.02.2013	3042465	Units _____	/each
	<b>Twin roller</b> Galvanized Stainless steel Galvanized for depth 80 with direct drive operator	09.07.2001 – 28.02.2013 09.07.2001 – 28.02.2013 01.06.2006 – 28.02.2013	3055174 3055326 3062261	Units _____ _____ _____	/each /each /each
	<b>Torsion spring for door section height TH &lt; 625 mm</b>	09.07.2001 – 28.02.2013	3055463	Units _____	/each
	<b>Torsion spring for door section height TH ≥ 625 mm</b>	09.07.2001 – 28.02.2013	3055462	Units _____	/each
	<b>Hinge type 4</b> Galvanized For wicket door with trip-free threshold from door widths of 5510 mm, galvanized Self-tapping screw A 6.5 x 16, dacromet Stainless steel For wicket door with trip-free threshold from door widths of 5510 mm, stainless steel Self-tapping screw A 6.5 x 16, stainless steel	09.07.2001 – 28.02.2013 02.11.2005 – 28.02.2013 09.07.2001 – 28.02.2013 02.11.2005 – 28.02.2013	3040030 3065446 3040982 3040033 3065920 3091360	Units _____ _____ _____ _____ _____ _____	/each /each /each /each /each /each

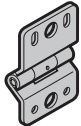
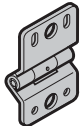
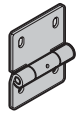
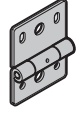

<b>ORDER</b>	Customer no.: _____	Order no./com.: _____	<b>*Please take information from the data label!</b>	
			Order no.:	Door no.:
	Customer name: _____		Product no.:	Type:
	Shipping address: _____		Year of manufacture:	
	Place/date: _____		Stamp and signature	

## 5. Fitting Parts for Door Sections

Article	Description	Production period	Art. no.	Qty.	€
	<b>Hinge type 6</b>			Units	
	Galvanized (with support)	09.07.2001 – 28.02.2013	3056279	_____	/each
	Galvanized (without support)	01.07.2005 – 28.02.2013	3038564	_____	/each
	Galvanized (without support), type 6-V, next to the wicket door	09.07.2001 – 28.02.2013	3042457	_____	/each
	Self-tapping screw A 6.5 × 16, dacromet		3040982	_____	/each
	Stainless steel (with support)	09.07.2001 – 28.02.2013	3091845	_____	/each
	Stainless steel (without support), type 6-V, next to the wicket door	09.07.2001 – 28.02.2013	3042460	_____	/each
	Self-tapping screw A 6.5 × 16, stainless steel		3091360	_____	/each
	<b>Support</b>	09.07.2001 – 28.02.2013	3038785	_____	/each
		<b>Hinge for wicket door</b>			Units
Galvanized (50 mm)		09.07.2001 – 28.02.2013	3040909	_____	/each
Self-tapping screw A 6.5 × 16, dacromet			3040982	_____	/each
Stainless steel (50 mm)		09.07.2001 – 28.02.2013	3040910	_____	/each
	<b>Centre hinge, depth 80</b>			Units	
	Galvanized	01.10.2005 – 28.02.2013	3062245	_____	/each
	Stainless steel	01.10.2005 – 28.02.2013	3089781	_____	/each
	<b>Side hinge, depth 80, type S, galvanized</b>			Units	
	Self-tapping screw A 6.5 × 75, dacromet	01.10.2005 – 28.02.2013	3065279	_____	/each
			3062892	_____	/each

<b>ORDER</b>	Customer no.: _____	Order no./com.: _____	<b>*Please take information from the data label!</b>	
	Customer name: _____	Product no.: _____	Order no.: _____	Door no.: _____
	Shipping address: _____	Year of manufacture: _____	Type: _____	
	Place/date: _____	Stamp and signature _____		



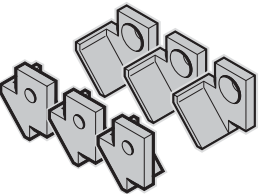
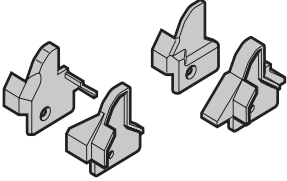

## 5. Fitting Parts for Door Sections

Article	Description	Production period	Art. no.	Qty.	€
	<b>Hinge type 4 FP</b>	01.02.2009 – 28.02.2013		Units	
	Galvanized		3076756	_____	/each
	Self-tapping screw A 6.5 × 16, dacromet		3040982	_____	/each
	Round-head screw M6 × 14, galvanized		3086084	_____	/each
	Hex nut M6, self-locking with flange, galvanized	3001660	_____	/each	
	Stainless steel	01.02.2009 – 28.02.2013	3076757	_____	/each
	Round-head screw M6 × 14, stainless steel		3073210	_____	/each
	Hex nut M6, self-locking with flange, stainless steel		3054418	_____	/each
Self-tapping screw A 6.5 × 16, stainless steel	3091360		_____	/each	
	<b>Hinge type 4 KR</b>	01.02.2009 – 28.02.2013		Units	
	Galvanized		3080732	_____	/each
	Self-tapping screw A 6.5 × 16, dacromet		3040982	_____	/each
	Round-head screw M6 × 14, galvanized		3086084	_____	/each
	Hex nut M6, self-locking with flange, galvanized	3001660	_____	/each	
	Stainless steel	01.02.2009 – 28.02.2013	3080733	_____	/each
	Round-head screw M6 × 14, stainless steel		3073210	_____	/each
	Hex nut M6, self-locking with flange, stainless steel		3054418	_____	/each
Self-tapping screw A 6.5 × 16, stainless steel	3091360		_____	/each	
	<b>Set: 3 wicket door hinge covers (with screws)</b>			Units	
	Without multiple-point locking	09.07.2001 – 28.02.2013	3091201	_____	/each
	With multiple-point locking	12.03.2012 – 28.02.2013	3090810	_____	/each
	<b>Set: Wicket door finger protection caps (with screws)</b>			Units	
	Hand hinged right	09.07.2001 – 28.02.2013	3090811	_____	/each
	Hand hinged left	09.07.2001 – 28.02.2013	3090812	_____	/each

<b>ORDER</b>	Customer no.: _____	Order no./com.: _____	<b>*Please take information from the data label!</b>	
			Order no.:	Door no.:
	Customer name: _____		Product no.:	Type:
	Shipping address: _____		Year of manufacture:	
	Place/date: _____		Stamp and signature	

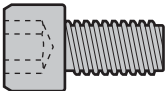

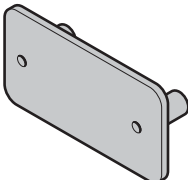
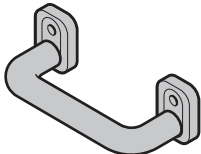
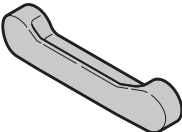
## 5. Fitting Parts for Door Sections

Article	Description	Production period	Art. no.	Qty.	€
	<b>Stop for doors with wicket doors</b>			Units	
	Without multiple-point locking	01.05.2005 – 11.03.2012	3063690	_____	/each
	Without / with multiple-point locking	12.03.2012 – 28.02.2013	3090617	_____	/each
	Flat-head screw M5 x 10		3064280	_____	/each
	<b>Cylinder screw M8 x 16, galvanized, with hexagon socket for stop</b>			Units	
	Washer 13 x 8 x 2, galvanized	01.03.2005 – 28.02.2013	3073756	_____	/each
		01.03.2005 – 28.02.2013	3073728	_____	/each
	<b>Section connecting strap</b>			Units	
	Self-tapping screw A 6.5 x 16, dacromet	09.07.2001 – 28.02.2013	3041428	_____	/each
			3040982	_____	/each
	<b>Handle plate</b>			Units	
	(0.75/1.5/3 mm) STE, ALR 40	09.07.2001 – 28.02.2013	3038378	_____	/each
	Tallow-drop screw M8 x 25		3041446	_____	/each
	(16 mm) ALR, TAR 40	09.07.2001 – 28.02.2013	3039973	_____	/each
	Tallow-drop screw M8 x 40		3041409	_____	/each
	(20 mm) TPU 40	09.07.2001 – 23.02.2006	3055022	_____	/each
	Tallow-drop screw M8 x 45		3055036	_____	/each
	(26 mm) ALR, TAR 40	09.07.2001 – 28.02.2013	3045653	_____	/each
Tallow-drop screw M8 x 50		3045689	_____	/each	
(42 mm) SPU, APU, TAP 40	09.07.2001 – 28.02.2013	3039974	_____	/each	
Tallow-drop screw M8 x 65		3041408	_____	/each	
	<b>Grip handle, interior</b>			Units	
		09.07.2001 – 28.02.2013	3013880	_____	/each
	<b>Exterior handle</b>			Units	
		09.07.2001 – 28.02.2013	3040840	_____	/each
	<b>T-handle, interior, with spacer</b>			Units	
	Tallow-drop screw M5 x 20 with cross recess	09.07.2001 – 28.02.2013	3053830	_____	/each
			3046324	_____	/each

<b>ORDER</b>	Customer no.:	Order no./com.:	<b>*Please take information from the data label!</b>	
			<b>Order no.:</b>	<b>Door no.:</b>
	Customer name:		<b>Product no.:</b>	<b>Type:</b>
	Shipping address:	<b>Year of manufacture:</b>		
	Place/date:	Stamp and signature		

## 5. Fitting Parts for Door Sections

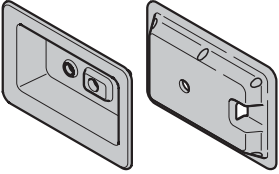
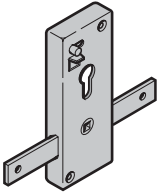
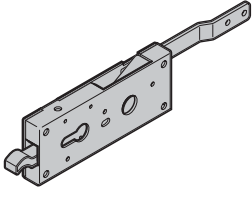
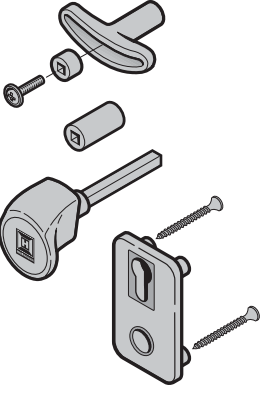
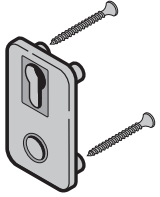
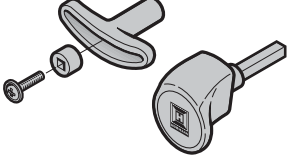
Article	Description	Production period	Art. no.	Qty.	€
	<b>Set: Shells, for recessed locking</b>			Units	
	PC version KABA version	01.06.2006 – 28.02.2013 01.06.2006 – 28.02.2013	3073867 3073868	_____ _____	/each /each
	<b>Lock</b>			Units	
	PC version KABA version	09.07.2001 – 28.02.2013 09.07.2001 – 28.02.2013	3039949 3039950	_____ _____	/each /each
	Wood screw 5 x 25, galvanized		3040064	_____	/each
	self-tapping screw B 6.3 x 16, dacromet		3021742	_____	/each
	<b>Lock, for recessed locking</b>			Units	
	PC version KABA version	01.06.2006 – 28.02.2013 01.06.2006 – 28.02.2013	3065942 3073518	_____ _____	/each /each
	<b>Door handle set TS, black plastic</b>			Units	
	1.5/3 mm, PC, ALR 40	09.07.2001 – 28.02.2013	3055146	_____	/each
	16 mm, PC, ALR, TAR 40	09.07.2001 – 28.02.2013	3055143	_____	/each
	26 mm, PC, ALR, TAR 40	09.07.2001 – 28.02.2013	3055140	_____	/each
	42 mm, PC, STE, TPU, SPU, APU, TAP 40	09.07.2001 – 28.02.2013	3055137	_____	/each
	80 mm, PZ, depth 80	01.10.2005 – 28.02.2013	3065300	_____	/each
	1.5/3 mm, KABA, ALR 40	09.07.2001 – 28.02.2013	3055147	_____	/each
	TS 16 mm, KABA, ALR, TAR 40	09.07.2001 – 28.02.2013	3055144	_____	/each
	TS 26 mm, KABA, ALR, TAR 40	09.07.2001 – 28.02.2013	3055141	_____	/each
	TS 42 mm, KABA, STE, TPU, SPU, APU, TAP 40	09.07.2001 – 28.02.2013	3055138	_____	/each
80 mm, KABA, depth 80	01.10.2005 – 28.02.2013	3065301	_____	/each	
	<b>Door handle base plate, black plastic, PC</b>	09.07.2001 – 28.02.2013	3039137	Units	/each
	<b>Set: Door handle, for recessed locking (with screws)</b>			Units	
	TS 42-V (SPU, APU) TS 80-V (depth 80)	01.06.2006 – 28.02.2013 01.06.2006 – 28.02.2013	3073616 3073619	_____ _____	/each /each

<b>ORDER</b>	Customer no.: _____	Order no./com.: _____	<b>*Please take information from the data label!</b>	
			Order no.:	Door no.:
	Customer name: _____		Product no.:	Type:
	Shipping address: _____		Year of manufacture:	
	Place/date: _____		Stamp and signature	

## 5. Fitting Parts for Door Sections

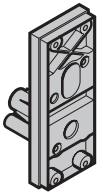
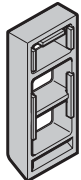
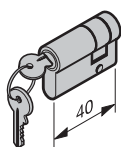
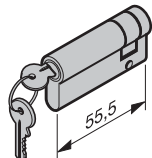
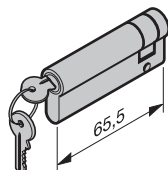
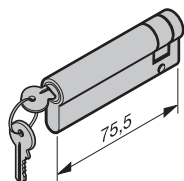
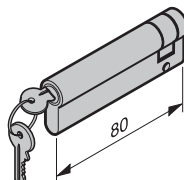
Article	Description	Production period	Art. no.	Qty.	€
	<b>Lock support</b>			Units	
	TS 1.5 - ALR 40	09.07.2001 – 28.02.2013	3039749	_____	/each
	TS 3 - ALR 40	09.07.2001 – 28.02.2013	3040387	_____	/each
	TS 16 - ALR, TAR 40	09.07.2001 – 28.02.2013	3039757	_____	/each
	TS 26 - ALR, TAR 40	09.07.2001 – 28.02.2013	3045662	_____	/each
	TS 42 - STE, TPU, SPU, APU, TAP 40, ASP	09.07.2001 – 28.02.2013	3039102	_____	/each
	<b>Lock support (TPU 40)</b>	09.07.2001 – 23.02.2006	3053612	Units	/each
	<b>Profile half cylinder, 30 + 10 mm, keys to differ, left closing lever, TS 1.5/3/42.5</b> 2 keys	09.07.2001 – 28.02.2013	3088642	Units	/each
	<b>Profile half cylinder, 45.5 + 10 mm, keys to differ, left closing lever, TS 16</b>	09.07.2001 – 28.02.2013	3014860	Units	/each
	<b>Profile half cylinder, 55.5 + 10 mm, keys to differ, left closing lever, TS 26</b>	09.07.2001 – 28.02.2013	3045692	Units	/each
	<b>Profile half cylinder, 65.5 + 10 mm, keys to differ with M5 x 35</b> For recessed locking, depth 80	01.07.2008 – 28.02.2013	3074400	Units	/each
	<b>Profile half cylinder, 70 + 10 mm, keys to differ, left closing lever, TS 42</b>	09.07.2001 – 28.02.2013	3091443	Units	/each

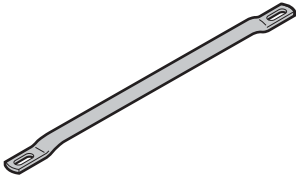
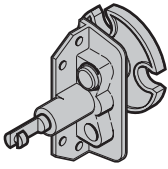
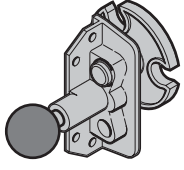
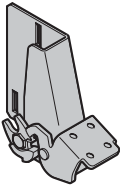
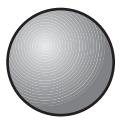
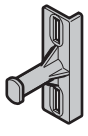
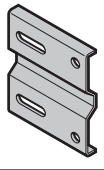
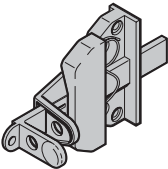

<b>ORDER</b>	Customer no.: _____	Order no./com.: _____	<b>*Please take information from the data label!</b>	
			<b>Order no.:</b> _____	<b>Door no.:</b> _____
	Customer name: _____		<b>Product no.:</b> _____	<b>Type:</b> _____
	Shipping address: _____		<b>Year of manufacture:</b> _____	
	Place/date: _____		Stamp and signature _____	

# 5. Fitting Parts for Door Sections

Article	Description	Production period	Art. no.	Qty.	€
	<b>Locking rod</b> L = 310 mm	09.07.2001 – 28.02.2013	3040329	Units	/each
	In special lengths, length _____ mm	09.07.2001 – 28.02.2013	3040280	_____	/each
	<b>Locking for exterior and interior operation</b>			Units	
	Right rotary latch	09.07.2001 – 28.02.2013	3041412	_____	/each
	Left rotary latch	09.07.2001 – 28.02.2013	3041413	_____	/each
	Self-tapping screw A 6.5 x 20, dacromet		3042487	_____	/each
	<b>Locking for interior operation</b>			Units	
	Right rotary latch	09.07.2001 – 28.02.2013	3035093	_____	/each
	Left rotary latch	09.07.2001 – 28.02.2013	3035107	_____	/each
	Self-tapping screw A 6.5 x 20, dacromet		3042487	_____	/each
	<b>Floor locking</b>			Units	
	Right	09.07.2001 – 28.02.2013	3054914	_____	/each
	Left	09.07.2001 – 28.02.2013	3054915	_____	/each
	Flat-head screw M8 x 13		3043106	_____	/each
	Flat-head screw M8 x 16		3043208	_____	/each
	Hex nut M8 with hollow flange		3018270	_____	/each
	<b>Ball knob M10</b>	09.07.2001 – 28.02.2013	3043186	Units	/each
	<b>Locking bolt</b>	09.07.2001 – 28.02.2013	3026264	Units	/each
	Flat-head screw M8 x 16		3043208	_____	/each
	Hex nut M8 with hollow flange		3018270	_____	/each
	<b>Locking plate</b>	09.07.2001 – 28.02.2013	3043207	Units	/each
	Flat-head screw M8 x 13		3043106	_____	/each
	Hex nut M8 with hollow flange		3018270	_____	/each
	<b>Shootbolt</b>	09.07.2001 – 28.02.2013	3060817	Units	/each
	Self-tapping screw A 6.5 x 20, dacromet		3042487	_____	/each

<b>ORDER</b>	Customer no.:	Order no./com.:	<b>*Please take information from the data label!</b>	
			Order no.:	Door no.:
	Customer name:		Product no.:	Type:
	Shipping address:	Year of manufacture:		
	Place/date:	Stamp and signature		

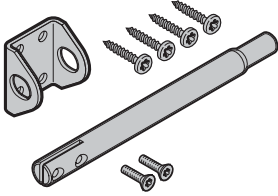
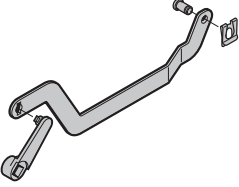
## 5. Fitting Parts for Door Sections

Article	Description	Production period	Art. no.	Qty.	€
	<b>Set: Shootbolt, for recessed locking</b>	01.06.2006 – 28.02.2013	3073864	Units _____	/each
	<b>Linkage for exterior and interior operation</b>			Units	
	Shootbolt, right Shootbolt, left	09.07.2001 – 28.02.2013 09.07.2001 – 28.02.2013	3055032 3055031	_____ _____	/each /each
	<b>Spring for shootbolt</b>	09.07.2001 – 28.02.2013	3073226	Units _____	/each



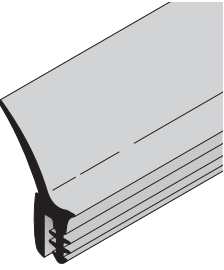

<b>ORDER</b>	Customer no.: _____ Order no./com.: _____	<b>*Please take information from the data label!</b>	
	Customer name: _____	Order no.: _____	Door no.: _____
	Shipping address: _____	Product no.: _____	Type: _____
	Place/date: _____	Year of manufacture: _____	
		Stamp and signature _____	

# 6. Frames

Article	Description	Production period	Art. no.	Qty.	€
	<p><b>* Angle frame side assembly</b></p> <p>Right Left</p> <p><b>Note:</b> Angle frame side assembly only available in the original length!</p>	<p>09.07.2001 – 28.02.2013 09.07.2001 – 28.02.2013</p>	<p>3086281 3086280</p>	<p>Units _____ _____</p>	<p>/m /m</p>
	<p><b>* Vertical track with square holes</b></p> <p>unperforated, Length _____ mm Right, with square holes Left, with square holes</p>	<p>09.07.2001 – 28.02.2013 09.07.2001 – 28.02.2013</p>	<p>3092887 3044801 3044800</p>	<p>Units _____ _____ _____</p>	<p>/m /m /m</p>
	<p><b>Side seal</b> Length _____ mm</p>	<p>09.07.2001 – 28.02.2013</p>	<p>3045687</p>	<p>Units _____</p>	<p>/m</p>

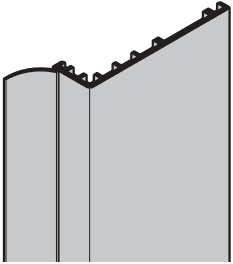
<b>ORDER</b>	Customer no.: _____	Order no./com.: _____	<b>*Please take information from the data label!</b>	
			Order no.:	Door no.:
	Customer name: _____		Product no.:	Type:
	Shipping address: _____		Year of manufacture:	
	Place/date: _____		Stamp and signature	

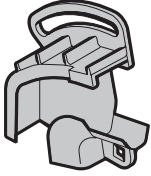
# 6. Frames

Article	Description	Production period	Art. no.	Qty.	€
	<b>Side seal ThermoFrame</b> Length _____ mm	01.05.2011 – 28.02.2013	3090367	Units _____	/m
*					
	<b>Horizontal track</b>			Units	
Right		09.07.2001 – 28.02.2013	3089361	_____	/m
Left		09.07.2001 – 28.02.2013	3089360	_____	/m
*					
	<b>Horizontal track, track application N3, ND3, NH3, H8, HD8</b>			Units	
Right		09.07.2001 – 28.02.2013	3043190	_____	/m
Left		09.07.2001 – 28.02.2013	3043189	_____	/m
	<b>Connecting piece for horizontal track, track application L, LD</b>			Units	
Right		09.07.2001 – 28.02.2013	3054709	_____	/each
Left		09.07.2001 – 28.02.2013	3054710	_____	/each
	Flat-head screw M8 x 16		3043208	_____	/each
	Hex nut M8 with hollow flange		3018270	_____	/each
*					
	<b>Connection rail</b>			Units	
	Flat-head screw M8 x 16	09.07.2001 – 28.02.2013	3038670	_____	/m
	Hex nut M8 with hollow flange		3043208	_____	/each
			3018270	_____	/each

<b>ORDER</b>	Customer no.: _____	Order no./com.: _____	<b>*Please take information from the data label!</b>	
			<b>Order no.:</b> _____	<b>Door no.:</b> _____
	Customer name: _____		<b>Product no.:</b> _____	<b>Type:</b> _____
	Shipping address: _____		<b>Year of manufacture:</b> _____	
	Place/date: _____		Stamp and signature _____	

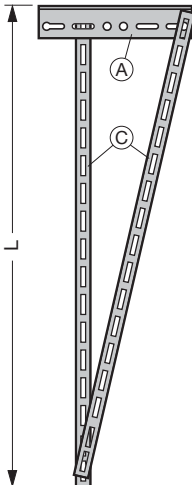
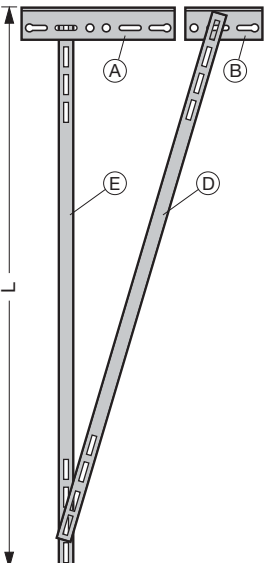
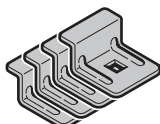

# 6. Frames

Article	Description	Production period	Art. no.	Qty.	€
	<b>Track suspension</b>			Units	
	Up to L = 469 mm	09.07.2001 – 28.02.2013	3042241	_____	/each
	Up to L = 833 mm	09.07.2001 – 28.02.2013	3042243	_____	/each
	Up to L = 1145 mm	09.07.2001 – 28.02.2013	3042245	_____	/each
	Up to L = 1499 mm	09.07.2001 – 28.02.2013	3042247	_____	/each
	(A) Grouting lug, long (323 mm)	09.07.2001 – 28.02.2013	3060743	_____	/each
	(C) C45 anchor				
	L = 469 mm	09.07.2001 – 28.02.2013	3044765	_____	/each
L = 833 mm	09.07.2001 – 28.02.2013	3044766	_____	/each	
L = 1145 mm	09.07.2001 – 28.02.2013	3044767	_____	/each	
L = 1499 mm	09.07.2001 – 28.02.2013	3044768	_____	/each	
	<b>Track suspension from L = 1500 mm to 2500 mm</b>			Units	
	(A) Grouting lug, long (323 mm)	09.07.2001 – 28.02.2013	3042249	_____	/each
	(B) Grouting lug, short (111 mm)	09.07.2001 – 28.02.2013	3060743	_____	/each
	(D) C45 anchor L = 1500 mm to 2500 mm	09.07.2001 – 28.02.2013	3060742	_____	/each
	(E) Track anchor, long	09.07.2001 – 28.02.2013	3044769	_____	/each
		09.07.2001 – 28.02.2013	3044761	_____	/each
	<b>Set: 2 track clips</b>	09.07.2001 – 28.02.2013	3085385	Units	/each

<b>ORDER</b>	Customer no.: _____	Order no./com.: _____	<b>*Please take information from the data label!</b>	
	Customer name: _____	Shipping address: _____	Order no.: _____	Door no.: _____
	Place/date: _____	Stamp and signature _____	Product no.: _____	Type: _____
			Year of manufacture: _____	

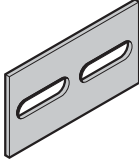
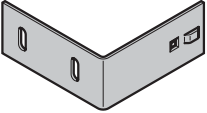
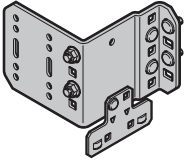
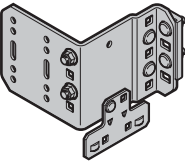
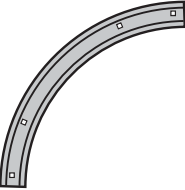

# 6. Frames

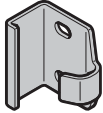
Article	Description	Production period	Art. no.	Qty.	€
	<b>Set: 2 fixing brackets for C-profile</b>	09.07.2001 – 28.02.2013	3085412	Units _____	/each
	<b>Gusset plate, track application not L/LD</b> Flat-head screw M8 x 16 Hex nut M8 with hollow flange	09.07.2001 – 28.02.2013	3043205 3043208 3018270	Units _____ _____ _____	/each /each /each
	<b>Gusset plate, track application L1, LD1 with connection angle</b> Left version Right version	09.07.2001 – 28.02.2013 09.07.2001 – 28.02.2013	3055260 3055261	Units _____ _____	/each /each
	<b>Gusset plate L2, LD2 with connection angle and spacer plate</b> Left version Right version	09.07.2001 – 28.02.2013 09.07.2001 – 28.02.2013	3055262 3055263	Units _____ _____	/each /each
	<b>Double radius 90°</b> Flat-head screw M8 x 13 Hex nut M8 with hollow flange	09.07.2001 – 28.02.2013	3094440 3043106 3018270	Units _____ _____ _____	/each /each /each
	* <b>Double radius segment for track application ND, NS, HD, HS, LD</b> Right Left Flat-head screw M8 x 13 Hex nut M8 with hollow flange	09.07.2001 – 28.02.2013 09.07.2001 – 28.02.2013	3044808 3044807 3043106 3018270	Units _____ _____ _____ _____	/each /each /each /each
	<b>Clip for vertical track</b> Flat-head screw M8 x 13 Hex nut M8 with hollow flange	09.07.2001 – 28.02.2013	3054696 3043106 3018270	Units _____ _____ _____	/each /each /each

<b>ORDER</b>	Customer no.: _____	Order no./com.: _____	<b>*Please take information from the data label!</b>	
			Order no.:	Door no.:
	Customer name: _____		Product no.:	Type:
	Shipping address: _____		Year of manufacture:	
	Place/date: _____		Stamp and signature _____	

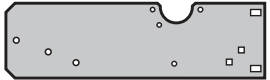
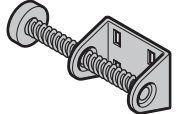
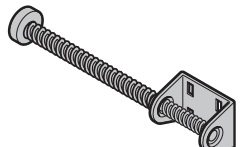
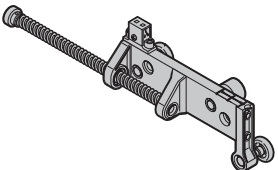
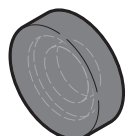

# 6. Frames

Article	Description	Production period	Art. no.	Qty.	€
	<b>Cantilever arm plate L</b>	09.07.2001 – 28.02.2013	3054859	Units	/each
	Flat-head screw M8 x 16		3043208	_____	/each
	Hex nut M8 with hollow flange		3018270	_____	/each
	<b>* Cantilever arm plate LD</b>	09.07.2001 – 28.02.2013		Units	
	2°		3088732	_____	/each
	4°		3082990	_____	/each
	6°		3088731	_____	/each
	8°		3082978	_____	/each
	10°		3082979	_____	/each
	12°		3082980	_____	/each
	14°		3082981	_____	/each
	16°		3082982	_____	/each
	18°		3082983	_____	/each
	20°		3082984	_____	/each
	22°		3082985	_____	/each
	24°		3082986	_____	/each
	26°		3082987	_____	/each
	28°		3082988	_____	/each
	30°		3082989	_____	/each
			Flat-head screw M8 x 16	3043208	_____
	Hex nut M8 with hollow flange	3018270	_____	/each	
	<b>Spring buffer, short</b>	09.07.2001 – 28.02.2013	3055175	Units	/each
	Flat-head screw M8 x 16		3043208	_____	/each
	Hex nut M8 with hollow flange		3018270	_____	/each
	<b>Spring buffer, long</b>	09.07.2001 – 28.02.2013	3044522	Units	/each
	Flat-head screw M8 x 16		3043208	_____	/each
	Hex nut M8 with hollow flange		3018270	_____	/each
	<b>Movable spring buffer</b>	09.07.2001 – 28.02.2013		Units	
	<b>Track application L, LD (only for doors with an operator)</b>				
	Right	09.07.2001 – 28.02.2013	3055244	_____	/each
	Left	09.07.2001 – 28.02.2013	3055240	_____	/each
	<b>Rubber buffer</b>	10.08.1992 – 06.07.2001	3005100	Units	/each

<b>ORDER</b>	Customer no.:	Order no./com.:	<b>*Please take information from the data label!</b>		
			Order no.:	Door no.:	
	Customer name:		Product no.:	Type:	
	Shipping address:	Year of manufacture:			
	Place/date:	Stamp and signature			

# 6. Frames

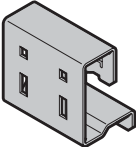
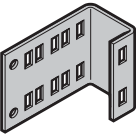
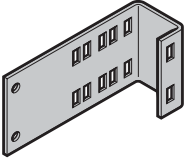
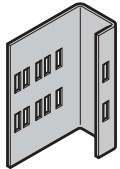
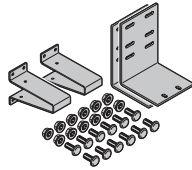
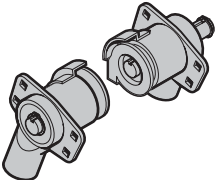
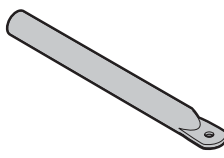
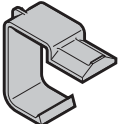
Article	Description	Production period	Art. no.	Qty.	€
	<b>Spring buffer bracket 6</b> <b>Track application N, H, HU</b> Round-head screw M8 x 22 Hex nut M8 with hollow flange	09.07.2001 – 28.02.2013	3073628 3035719 3018270	Units _____ _____ _____	/each /each /each
	<b>Spring buffer bracket 2</b> <b>Track application L, LD</b> Round-head screw M8 x 22 Hex nut M8 with hollow flange	09.07.2001 – 28.02.2013	3040746 3035719 3018270	Units _____ _____ _____	/each /each /each
	<b>Spring buffer bracket 1</b> <b>Track application V, VU</b> Round-head screw M8 x 22 Hex nut M8 with hollow flange	09.07.2001 – 28.02.2013	3040745 3035719 3018270	Units _____ _____ _____	/each /each /each
	<b>Spring buffer bracket 3</b> <b>Track application N3, H8, HS5</b> Flat-head screw M8 x 16 Hex nut M8 with hollow flange	09.07.2001 – 28.02.2013	3045008 3043208 3018270	Units _____ _____ _____	/each /each /each
	<b>Set: spring buffers</b> <b>below the track</b>	09.07.2001 – 28.02.2013	3088487	Units _____ _____	/each
	<b>Set: Ball-bearing, track application L, LD</b> Right (door operated on right side) Left (door operated on left side) for ITO 400 operators and SupraMatic	09.07.2001 – 28.02.2013 09.07.2001 – 28.02.2013 09.07.2001 – 28.02.2013	3060732 3060733 3091847	Units _____ _____ _____	/each /each /each
	<b>Torque support</b> <b>Track application L, LD</b> Flat-head screw M8 x 16 Hex nut M8 with hollow flange	09.07.2001 – 28.02.2013	3095342 3043208 3018270	Units _____ _____ _____	/each /each /each
	<b>Chain support</b> <b>Track application L, LD</b>	09.07.2001 – 28.02.2013	3054860	Units _____ _____	/each

<b>ORDER</b>	Customer no.: _____	Order no./com.: _____	<b>*Please take information from the data label!</b>	
			Order no.: _____	Door no.: _____
	Customer name: _____		Product no.: _____	Type: _____
	Shipping address: _____		Year of manufacture: _____	
	Place/date: _____		Stamp and signature _____	

# 6. Frames

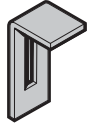
Article	Description	Production period	Art. no.	Qty.	€
	<b>Support profile for moveable spring buffer</b> <b>Track application L, LD</b>	09.07.2001 – 28.02.2013	3055245	Units _____	/each

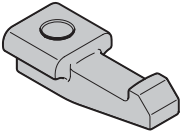
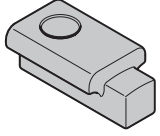
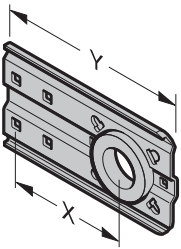

<b>ORDER</b>	Customer no.: _____ Order no./com.: _____	<b>*Please take information from the data label!</b>	
	Customer name: _____	Order no.: _____	Door no.: _____
	Shipping address: _____	Product no.: _____	Type: _____
	Place/date: _____	Year of manufacture: _____	
		Stamp and signature _____	

# 7. Torsion Spring Shafts

Article	Description	Production period	Art. no.	Qty.	€
	<b>Spring shaft 40 x 3, with groove</b> (max 6500 mm)	09.07.2001 – 28.02.2013	3045688	Units _____	/m
	<b>Set: Clamping wedge with chamfer and drilling screw 5.5 x 25-K</b>	09.07.2001 – 28.02.2013	3085682	Units _____	/each
	<b>Set: (2) fitting for ball-bearing and drilling screw 5.5 x 25-K</b>	09.07.2001 – 28.02.2013	3085683	Units _____	/each
	<b>Shaft support</b> (door leaf weight < 400 kg, number of springs ≤ 2, single spring shaft)			Units	
	x = 120, y = 192 Size 1	09.07.2001 – 28.02.2013	3015220	_____	/each
	Size 2 (for L and LD) x = 140, y = 212 Size 2	09.07.2001 – 28.02.2013	3011151	_____	/each
	Size 4 (not with low-mounted spring shaft) Size 6				
	x = 160, y = 232 Size 4 (with low-mounted spring shaft) Size 5 (not with low-mounted spring shaft) Size 7	09.07.2001 – 28.02.2013	3011160	_____	/each
	Hexagon screw M10 x 20, galvanized		3001555	_____	/each
	Hex nut M10 with flange and head teeth		3054148	_____	/each

<b>ORDER</b>	Customer no.: _____	Order no./com.: _____	<b>*Please take information from the data label!</b>	
			Order no.:	Door no.:
	Customer name: _____		Product no.:	Type:
	Shipping address: _____		Year of manufacture:	
	Place/date: _____		Stamp and signature	

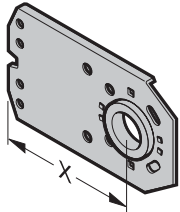
# 7. Torsion Spring Shafts

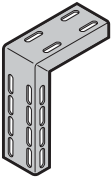
Article	Description	Production period	Art. no.	Qty.	€	
	<b>Shaft support 136</b> x = 120 Size 1 Size 2 (for L and LD)	09.07.2001 – 28.02.2013	3082509	Units	/each	
	x = 140 Size 2 Size 4 (not with low-mounted spring shaft) Size 6	09.07.2001 – 28.02.2013	3082510	_____	/each	
	x = 160 Size 3 Size 4 (with low-mounted spring shaft) Size 5 (not with low-mounted spring shaft) Size 7	09.07.2001 – 28.02.2013	3082511	_____	/each	
	x = 185 Size 5 (with low-mounted spring shaft) Size 8 Size 9 (except for VU)	09.07.2001 – 28.02.2013	3082512	_____	/each	
	x = 200, VU 9 Round-head screw M10 x 20, galvanized Hex nut M10 with flange and head teeth	09.07.2001 – 28.02.2013	3082513	_____	/each	
				3043210	_____	/each
				3054148	_____	/each
					Units	/each
					_____	/each
					_____	/each
	<b>Shaft support connection</b> Round-head screw M10 x 20, galvanized Hex nut M10 with flange and head teeth	09.07.2001 – 28.02.2013	3043121	Units	/each	
				_____	/each	
				3054148	_____	/each
	<b>Rear suspension Track application L, LD</b> 298 mm long, left 298 mm long, right 498 mm long, right 498 mm long, left Shortened, right Shortened, left Length _____ mm (max. 1500 mm) Round-head screw M10 x 20 Hex nut M10 with head teeth and flange	09.07.2001 – 28.02.2013	3095338	Units	/each	
		09.07.2001 – 28.02.2013	3095339	_____	/each	
		09.07.2001 – 28.02.2013	3095341	_____	/each	
		09.07.2001 – 28.02.2013	3095340	_____	/each	
		09.07.2001 – 28.02.2013	3087493	_____	/each	
		09.07.2001 – 28.02.2013	3087494	_____	/each	
				3043210	_____	/each
				3054148	_____	/each
					_____	/each
					_____	/each

<b>ORDER</b>	Customer no.: _____	Order no./com.: _____	<b>*Please take information from the data label!</b>	
			Order no.:	Door no.:
	Customer name: _____		Product no.:	Type:
	Shipping address: _____		Year of manufacture:	
	Place/date: _____		Stamp and signature _____	

# 7. Torsion Spring Shafts

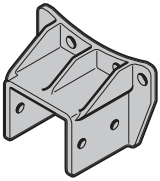
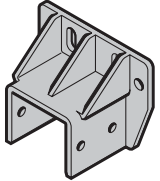
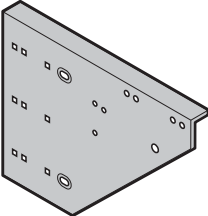
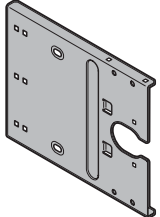
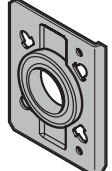
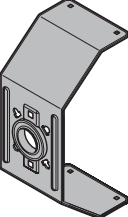
Article	Description	Production period	Art. no.	Qty.	€
	<b>Shaft support bracket for cable drum</b> <b>Track application VU, HU</b>  With tube 120 × 60 × 2 / 120 × 60 × 3 With tube 60 × 60 × 2 Hexagon head tapping screw B8 × 22, Geomet	09.07.2001 – 28.02.2013	3041353	Units	/each
		09.07.2001 – 28.02.2013	3042023	_____	/each
			3037010	_____	/each
	<b>Shaft support bracket</b> <b>Track application VU, HU</b>  With tube 120 × 60 × 2 / 120 × 60 × 3 With tube 60 × 60 × 2 Hexagon head tapping screw B8 × 22, Geomet	09.07.2001 – 28.02.2013	3041351	Units	/each
		09.07.2001 – 28.02.2013	3042022	_____	/each
			3037010	_____	/each
	<b>* Support bracket</b>  U1: HU 4+5, VU 6+7, right U1: HU 4+5, VU 6+7, left U2: RG 4+5, WG 6+7, right U2: RG 4+5, WG 6+7, left U3: VU 9, right U3: VU 9, left	09.07.2001 – 28.02.2013	3043198	Units	/each
		09.07.2001 – 28.02.2013	3043191	_____	/each
		09.07.2001 – 28.02.2013	3065320	_____	/each
		09.07.2001 – 28.02.2013	3065319	_____	/each
		09.07.2001 – 28.02.2013	3065322	_____	/each
		09.07.2001 – 28.02.2013	3065321	_____	/each
	<b>Support bracket U4</b>	03.07.2009 – 28.02.2013	3076583	Units	/each
	<b>Flange bearing</b> Round-head screw M6 × 14 Self-locking nut with serrated bearing M6	03.07.2009 – 28.02.2013	3076653	Units	/each
			3086084	_____	/each
			3001660	_____	/each
	<b>Torque support</b> Round-head screw M6 × 14 Self-locking nut with serrated bearing M6	03.07.2009 – 28.02.2013	3076654	Units	/each
			3086084	_____	/each
			3001660	_____	/each

<b>ORDER</b>	Customer no.:	Order no./com.:	<b>*Please take information from the data label!</b>	
			Order no.:	Door no.:
	Customer name:		Product no.:	Type:
	Shipping address:	Year of manufacture:		
	Place/date:	Stamp and signature		

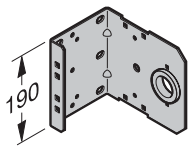
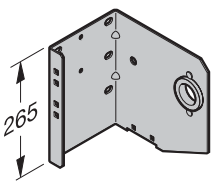
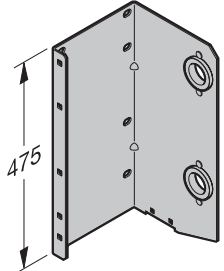
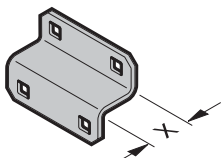

# 7. Torsion Spring Shafts

Article	Description	Production period	Art. no.	Qty.	€
	<b>Shaft support bracket 1, with ball-bearing</b> Right, size 2 Left, size 2	09.07.2001 – 28.02.2013 09.07.2001 – 28.02.2013	3044813 3044812	Units _____ _____	/each /each
	<b>Shaft support bracket 2, with ball-bearing</b> WE = 160, right, size 4 WE = 160, left, size 4 WE = 180, right, size 3, 5, 7 WE = 180, left, size 3, 5, 7	09.07.2001 – 28.02.2013 09.07.2001 – 28.02.2013 09.07.2001 – 28.02.2013 09.07.2001 – 28.02.2013	3044139 3044138 3044141 3044140	Units _____ _____ _____ _____	/each /each /each /each
	<b>Shaft support bracket 3, with ball-bearing</b> Right, size 8, 9 Left, size 8, 9	09.07.2001 – 28.02.2013 09.07.2001 – 28.02.2013	3044143 3044142	Units _____ _____	/each /each
	<b>Shaft support bracket 4, with ball-bearing</b> Right, size 3, 5, 7 Left, size 3, 5, 7	09.07.2001 – 28.02.2013 09.07.2001 – 28.02.2013	3044147 3044146	Units _____ _____	/each /each
	<b>Shaft support bracket 5, with ball-bearing</b> Right, size 3, 5, 7 Left, size 3, 5, 7	09.07.2001 – 28.02.2013 09.07.2001 – 28.02.2013	3044147 3044146	Units _____ _____	/each /each
	<b>Shaft support bracket 5, with ball-bearing</b> Right, size 8, 9 Left, size 8, 9	09.07.2001 – 28.02.2013 09.07.2001 – 28.02.2013	3044151 3044150	Units _____ _____	/each /each
	<b>Support angle for bracket</b> x = 19 mm x = 26 mm x = 33 mm x = 40 mm Flat-head screw M8 x 13 Hex nut M8 with hollow flange	09.07.2001 – 28.02.2013 09.07.2001 – 28.02.2013 09.07.2001 – 28.02.2013 09.07.2001 – 28.02.2013	3088620 3081990 3081991 3081992 3043106 3018270	Units _____ _____ _____ _____ _____ _____	/each /each /each /each /each /each

<b>ORDER</b>	Customer no.: _____	Order no./com.: _____	<b>*Please take information from the data label!</b>	
			Order no.: _____	Door no.: _____
	Customer name: _____		Product no.: _____	Type: _____
	Shipping address: _____		Year of manufacture: _____	
	Place/date: _____		Stamp and signature _____	

# 7. Torsion Spring Shafts

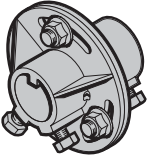
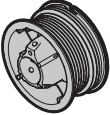
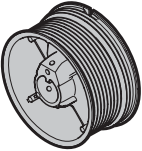
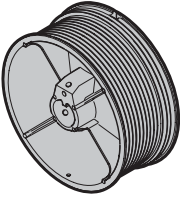
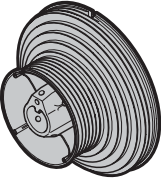
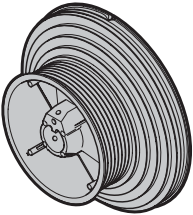
Article	Description	Production period	Art. no.	Qty.	€
	<b>Flexible coupling</b> (incl. 3 round-head screws M8 x 16 and nuts, and 4 hexagon screws M8 x 20)	09.07.2001 – 28.02.2013	3044205	Units _____	/each
	<b>* Cable drum size 1</b> <b>Track application N, ND, NS, NH, L, LD</b>			Units _____	
	Right	09.07.2001 – 28.02.2013	3072582	_____	/each
	Left	09.07.2001 – 28.02.2013	3072581	_____	/each
	<b>* Cable drum size 2</b> <b>Track application N, ND, NS, NH, L, LD</b>			Units _____	
	Right	09.07.2001 – 28.02.2013	3086200	_____	/each
	Left	09.07.2001 – 28.02.2013	3086199	_____	/each
	<b>* Cable drum size 3</b> <b>Track application N, ND, NS, NH</b>			Units _____	
	Right	09.07.2001 – 28.02.2013	3086194	_____	/each
	Left	09.07.2001 – 28.02.2013	3086193	_____	/each
	<b>* Cable drum size 4</b> <b>Track application H, HD, HS, HU</b>			Units _____	
	Right for cable Ø 5.5 mm	09.07.2001 – 28.02.2013	3044607	_____	/each
	Left for cable Ø 5.5 mm	09.07.2001 – 28.02.2013	3044608	_____	/each
	Right for cable Ø 4 mm	01.02.2008 – 28.02.2013	3086204	_____	/each
	Left for cable Ø 4 mm	01.02.2008 – 28.02.2013	3086203	_____	/each
	<b>Cable drum size 5</b> <b>Track application H, HD, HS, HU</b>			Units _____	
	Right	09.07.2001 – 28.02.2013	3086206	_____	/each
	Left	09.07.2001 – 28.02.2013	3086205	_____	/each

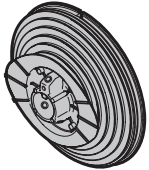
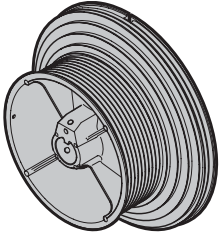
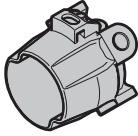
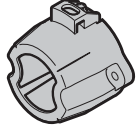

<b>ORDER</b>	Customer no.: _____	Order no./com.: _____	<b>*Please take information from the data label!</b>	
			Order no.: _____	Door no.: _____
	Customer name: _____		Product no.: _____	Type: _____
	Shipping address: _____		Year of manufacture: _____	
	Place/date: _____		Stamp and signature _____	

# 7. Torsion Spring Shafts

Article	Description	Production period	Art. no.	Qty.	€
	<b>* Cable drum size 6</b> <b>Track application V, VU</b>  Right Left	09.07.2001 – 28.02.2013 09.07.2001 – 28.02.2013	3086208 3086207	Units _____ _____	/each /each
	<b>* Cable drum size 7</b> <b>Track application V, VU</b>  Right Left	09.07.2001 – 28.02.2013 09.07.2001 – 28.02.2013	3086210 3086209	Units _____ _____	/each /each
	<b>* Cable drum size 8</b> <b>Track application H, HD, HS</b>  Right Left	09.07.2001 – 28.02.2013 09.07.2001 – 28.02.2013	3086196 3086195	Units _____ _____	/each /each
	<b>* Cable drum size 9</b> <b>Track application V, VU</b>  Right Left	09.07.2001 – 28.02.2013 09.07.2001 – 28.02.2013	3086198 3086197	Units _____ _____	/each /each
	<b>Tensioning cone size 2 with spring clips for inside spring diameter 95 mm</b>	09.07.2001 – 28.02.2013	3072886	Units _____	/each
	<b>Spring cone size 2 with spring clips for inside spring diameter 95 mm</b>	09.07.2001 – 28.02.2013	3072885	Units _____	/each

<b>ORDER</b>	Customer no.: _____	Order no./com.: _____	<b>*Please take information from the data label!</b>	
			Order no.: _____	Door no.: _____
	Customer name: _____		Product no.: _____	Type: _____
	Shipping address: _____		Year of manufacture: _____	
	Place/date: _____		Stamp and signature _____	

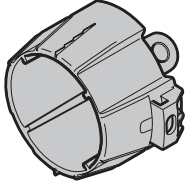
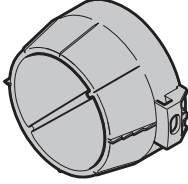
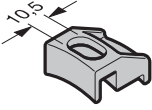
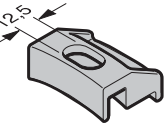
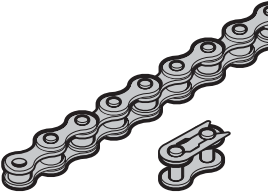
# 7. Torsion Spring Shafts

Article	Description	Production period	Art. no.	Qty.	€
	<b>Tensioning cone size 3 with spring clips for inside spring diameter 142 mm</b>	09.07.2001 – 28.02.2013	3072888	Units _____	/each
	<b>Spring cone size 3 with spring clips for inside spring diameter 142 mm</b>	09.07.2001 – 28.02.2013	3072887	Units _____	/each
	<b>Spring clip size 2</b>	09.07.2001 – 28.02.2013	3011100	Units _____	/each
	<b>Spring clip size 4</b>	09.07.2001 – 28.02.2013	3038602	Units _____	/each
	<b>Roller chain with clip master link</b>			Units	
	for double spring shaft				
	L = 889 mm	09.07.2001 – 28.02.2013	3044620	_____	/each
	L = 1245 mm	09.07.2001 – 28.02.2013	3044621	_____	/each
	L = 1321 mm	09.07.2001 – 28.02.2013	3044622	_____	/each
L = 1346 mm	09.07.2001 – 28.02.2013	3086078	_____	/each	
L = 1372 mm	09.07.2001 – 28.02.2013	3085665	_____	/each	
	<b>Spacer tube for double spring shaft</b>			Units	
	L = 28 mm L = 34 mm	09.07.2001 – 28.02.2013 09.07.2001 – 28.02.2013	3044113 3044114	_____ _____	/each /each
	<b>Chain tensioner for double spring shaft</b>			Units	
	Right Left	09.07.2001 – 28.02.2013 09.07.2001 – 28.02.2013	3044710 3044711	_____ _____	/each /each

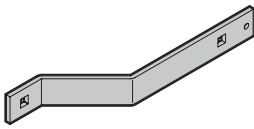
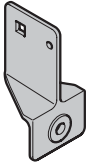
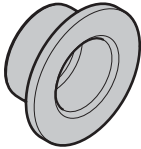
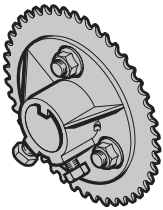

<b>ORDER</b>	Customer no.: _____	Order no./com.: _____	<b>*Please take information from the data label!</b>	
			Order no.:	Door no.:
	Customer name: _____		Product no.:	Type:
	Shipping address: _____		Year of manufacture:	
	Place/date: _____		Stamp and signature	

# 7. Torsion Spring Shafts

Article	Description	Production period	Art. no.	Qty.	€
	<b>Retaining angle for chain tensioner for double spring shaft</b>	01.03.2013 –	3043758	Units _____	/each
	<b>Chain tensioner holder</b>	16.10.2009 – 28.02.2013	3086479	Units _____	/each
	<b>Support sleeve for leg spring</b>	09.07.2001 – 28.02.2013	3002225	Units _____	/each
	<b>Chain sprocket for double spring shaft, cpl. with fixing material and operator connection</b>	09.07.2001 – 28.02.2013	3044739	Units _____	/each

<b>ORDER</b>	Customer no.: _____	Order no./com.: _____	<b>*Please take information from the data label!</b>	
			Order no.: _____	Door no.: _____
	Customer name: _____		Product no.: _____	Type: _____
	Shipping address: _____		Year of manufacture: _____	
	Place/date: _____		Stamp and signature _____	

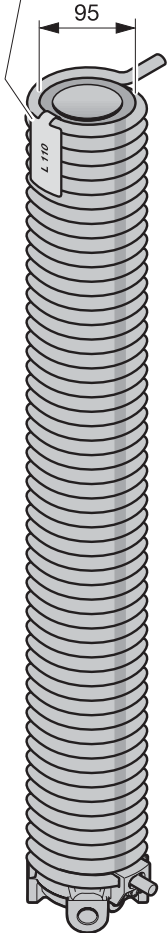
# 7. Torsion Spring Shafts



Article	Description	Production period	Art. no.	Qty.	€
Spring identification * (plastic label)	<b>Torsion spring with plastic tube and tensioning cone</b>			Units	
	R105	01.07.2011 – 28.02.2013	3090546	_____	/each
	L105	01.07.2011 – 28.02.2013	3090545	_____	/each
	R106	01.07.2011 – 28.02.2013	3090547	_____	/each
	R107	01.07.2011 – 28.02.2013	3090548	_____	/each
	R108	01.07.2011 – 28.02.2013	3090549	_____	/each
	R109	01.07.2011 – 28.02.2013	3090550	_____	/each
	R110	09.07.2001 – 28.02.2013	3074278	_____	/each
	L110	09.07.2001 – 28.02.2013	3074279	_____	/each
	R111	09.07.2001 – 28.02.2013	3074280	_____	/each
	R112	09.07.2001 – 28.02.2013	3074281	_____	/each
	R113	09.07.2001 – 28.02.2013	3074282	_____	/each
	R114	09.07.2001 – 28.02.2013	3074283	_____	/each
	R115	09.07.2001 – 28.02.2013	3074284	_____	/each
	R116	09.07.2001 – 28.02.2013	3074285	_____	/each
	R117	09.07.2001 – 28.02.2013	3074286	_____	/each
	L117	01.07.2011 – 28.02.2013	3090551	_____	/each
	R118	09.07.2001 – 28.02.2013	3074287	_____	/each
	R119	09.07.2001 – 28.02.2013	3074288	_____	/each
	R120	09.07.2001 – 28.02.2013	3074289	_____	/each
	R121	09.07.2001 – 28.02.2013	3074290	_____	/each
	R122	09.07.2001 – 28.02.2013	3074291	_____	/each
	R123	09.07.2001 – 28.02.2013	3074292	_____	/each
	R124	09.07.2001 – 28.02.2013	3074293	_____	/each
	R125	09.07.2001 – 28.02.2013	3074294	_____	/each
	R126	09.07.2001 – 28.02.2013	3074295	_____	/each
	R127	09.07.2001 – 28.02.2013	3074296	_____	/each
	R128	09.07.2001 – 28.02.2013	3074297	_____	/each
	R129	09.07.2001 – 28.02.2013	3074298	_____	/each
	R130	09.07.2001 – 28.02.2013	3074299	_____	/each
	R131	09.07.2001 – 28.02.2013	3074300	_____	/each
	R132	09.07.2001 – 28.02.2013	3074301	_____	/each
	L132	09.07.2001 – 28.02.2013	3074302	_____	/each
		Special spring, left (e.g. L95 – 8.0 – 1100) L _____ - _____ - _____	09.07.2001 – 28.02.2013	3054697 	_____
	Special spring, right (e.g. R95 – 8.0 – 1100) R _____ - _____ - _____	09.07.2001 – 28.02.2013	3058150 	_____	

**Safety instructions:**

Always replace all springs. Spring layout is based on a specified number of load cycles. If one spring in the door breaks, the other springs are also near to the breaking point and may soon break.

<b>ORDER</b>	Customer no.: _____	Order no./com.: _____	<b>*Please take information from the data label!</b>	
			Order no.: _____	Door no.: _____
	Customer name: _____		Product no.: _____	Type: _____
	Shipping address: _____		Year of manufacture: _____	
	Place/date: _____		Stamp and signature _____	

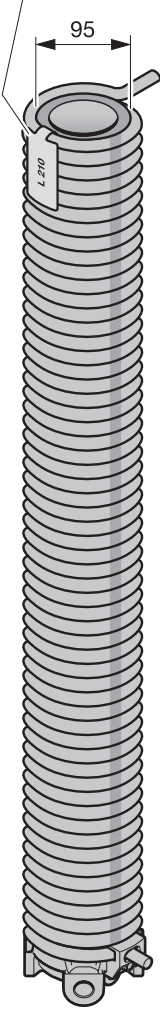
# 7. Torsion Spring Shafts

Article	Description	Production period	Art. no.	Qty.	€
Spring identification (plastic label) *	<b>Torsion spring with plastic tube and tensioning cone</b>			Units	
	R205	01.07.2011 – 28.02.2013	3090553	_____	/each
	L205	01.07.2011 – 28.02.2013	3090552	_____	/each
	R206	01.07.2011 – 28.02.2013	3090554	_____	/each
	R207	01.07.2011 – 28.02.2013	3090555	_____	/each
	R208	01.07.2011 – 28.02.2013	3090556	_____	/each
	R209	01.07.2011 – 28.02.2013	3090557	_____	/each
	R210	09.07.2001 – 28.02.2013	3074303	_____	/each
	L210	09.07.2001 – 28.02.2013	3074304	_____	/each
	R211	09.07.2001 – 28.02.2013	3074305	_____	/each
	R212	09.07.2001 – 28.02.2013	3074306	_____	/each
	R213	09.07.2001 – 28.02.2013	3074307	_____	/each
	R214	09.07.2001 – 28.02.2013	3074308	_____	/each
	R215	09.07.2001 – 28.02.2013	3074309	_____	/each
	R216	09.07.2001 – 28.02.2013	3074310	_____	/each
	R217	09.07.2001 – 28.02.2013	3074311	_____	/each
	L217	01.07.2011 – 28.02.2013	3090558	_____	/each
	R218	09.07.2001 – 28.02.2013	3074312	_____	/each
	R219	09.07.2001 – 28.02.2013	3074313	_____	/each
	R220	09.07.2001 – 28.02.2013	3074314	_____	/each
	R221	09.07.2001 – 28.02.2013	3074315	_____	/each
	R222	09.07.2001 – 28.02.2013	3074316	_____	/each
	L222	01.07.2011 – 28.02.2013	3090559	_____	/each
	R223	09.07.2001 – 28.02.2013	3074317	_____	/each
	R224	09.07.2001 – 28.02.2013	3074318	_____	/each
	R225	09.07.2001 – 28.02.2013	3074319	_____	/each
	R226	09.07.2001 – 28.02.2013	3074320	_____	/each
	R227	09.07.2001 – 28.02.2013	3074321	_____	/each
	L227	09.07.2001 – 28.02.2013	3074322	_____	/each
	Special spring, left (e.g. L95 – 8.0 – 1100) L _____ - _____ - _____	09.07.2001 – 28.02.2013	3054697 	_____	
	Special spring, right (e.g. R95 – 8.0 – 1100) R _____ - _____ - _____	09.07.2001 – 28.02.2013	3058150 	_____	



**Safety instructions:**  
Always replace all springs. Spring layout is based on a specified number of load cycles. If one spring in the door breaks, the other springs are also near to the breaking point and may soon break.

<b>ORDER</b>	Customer no.:	Order no./com.:	<b>*Please take information from the data label!</b>	
			Order no.:	Door no.:
	Customer name:		Product no.:	Type:
	Shipping address:	Year of manufacture:		
	Place/date:	Stamp and signature		



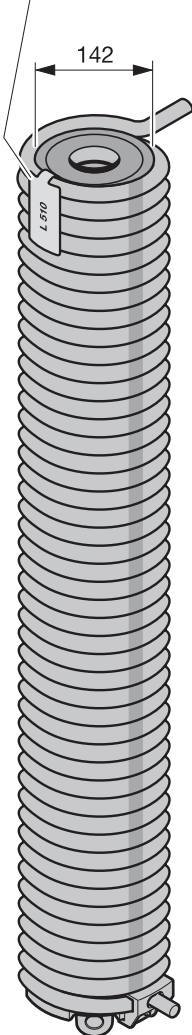

# 7. Torsion Spring Shafts

Article	Description	Production period	Art. no.	Qty.	€	
Spring identification (plastic label) *	<b>Torsion spring with plastic tube and tensioning cone</b>			Units		
	R510	09.07.2001 – 28.02.2013	3074351	_____	/each	
	L510	09.07.2001 – 28.02.2013	3074352	_____	/each	
	R511	09.07.2001 – 28.02.2013	3074353	_____	/each	
	R512	09.07.2001 – 28.02.2013	3074354	_____	/each	
	R513	09.07.2001 – 28.02.2013	3074355	_____	/each	
	R514	09.07.2001 – 28.02.2013	3074356	_____	/each	
	R515	09.07.2001 – 28.02.2013	3074357	_____	/each	
	R516	09.07.2001 – 28.02.2013	3074358	_____	/each	
	R517	09.07.2001 – 28.02.2013	3074359	_____	/each	
	R518	09.07.2001 – 28.02.2013	3074360	_____	/each	
	R519	09.07.2001 – 28.02.2013	3074361	_____	/each	
	R520	09.07.2001 – 28.02.2013	3074362	_____	/each	
	R521	09.07.2001 – 28.02.2013	3074363	_____	/each	
	R522	09.07.2001 – 28.02.2013	3074364	_____	/each	
	R523	09.07.2001 – 28.02.2013	3074365	_____	/each	
	R524	09.07.2001 – 28.02.2013	3074366	_____	/each	
	R525	09.07.2001 – 28.02.2013	3074367	_____	/each	
	R526	09.07.2001 – 28.02.2013	3074368	_____	/each	
	L526	09.07.2001 – 28.02.2013	3074369	_____	/each	
		Special spring, left (e.g. L142 – 11.0 – 1300) L _____ – _____ – _____	09.07.2001 – 28.02.2013	3054697 	_____	
		Special spring, right (e.g. R142 – 11.0 – 1300) R _____ – _____ – _____	09.07.2001 – 28.02.2013	3058150 	_____	

**Safety instructions:**  
Always replace all springs. Spring layout is based on a specified number of load cycles. If one spring in the door breaks, the other springs are also near to the breaking point and may soon break.

<b>ORDER</b>	Customer no.: _____	Order no./com.: _____	<b>*Please take information from the data label!</b>	
	Customer name: _____	Shipping address: _____	Order no.: _____	Door no.: _____
	Place/date: _____	Stamp and signature _____	Product no.: _____	Type: _____
			Year of manufacture: _____	

# 7. Torsion Spring Shafts

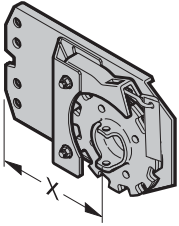
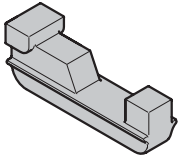
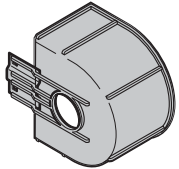
Article	Description	Production period	Art. no.	Qty.	€	
	<b>* Spring safety device</b> x = 120 mm, right, size 1 x = 120 mm, left, size 1 x = 140 mm, right, size 2, 4, 6 x = 140 mm, left, size 2, 4, 6 x = 160 mm, right, size 3, 5, 7 x = 160 mm, left, size 3, 5, 7 x = 185 mm, right, size 8, 9 x = 185 mm, left, size 8, 9 x = 200 mm, right, VU 9 x = 200 mm, left, VU 9	09.07.2001 – 28.02.2013 09.07.2001 – 28.02.2013 09.07.2001 – 28.02.2013 09.07.2001 – 28.02.2013 09.07.2001 – 28.02.2013 09.07.2001 – 28.02.2013 09.07.2001 – 28.02.2013 09.07.2001 – 28.02.2013 09.07.2001 – 28.02.2013 09.07.2001 – 28.02.2013	3044639 3044638 3044641 3044640 3044643 3044642 3044645 3044644 3044647 3044646	Units _____ _____ _____ _____ _____ _____ _____ _____ _____ _____	/each /each /each /each /each /each /each /each /each /each	
		<b>* Connecting wedge for spring safety device</b>	09.07.2001 – 28.02.2013	3090146	Units _____	/each
		<b>* Cable drum cover Track application L, complete with fastening</b> Size 1, plastic Size 2, galvanized	09.07.2001 – 28.02.2013 19.04.2012 – 28.02.2013	3055423 3090870	Units _____ _____	/each /each

<b>ORDER</b>	Customer no.: _____	Order no./com.: _____	<b>*Please take information from the data label!</b>	
			Order no.: _____	Door no.: _____
	Customer name: _____		Product no.: _____	Type: _____
	Shipping address: _____		Year of manufacture: _____	
Place/date: _____		Stamp and signature _____		

# 8. Fitting Parts for Doors

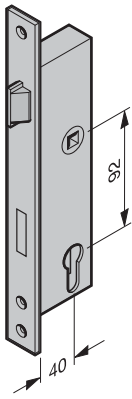
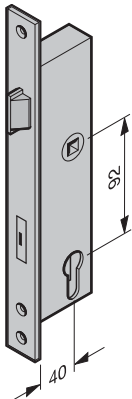
Article	Description	Production period	Art. no.	Qty.	€
	<b>Tubular profile mortice lock</b>			Units	
	1314 (40/92/9) PC, R/L, for side door and wicket door	09.07.2001 – 28.02.2013	3070038	_____	/each
	1212 (40/92/9) Kaba, R/L, for side door	09.07.2001 – 28.02.2003	3043327	_____	/each
	1314 (40/92/9) Kaba, R/L, for side door	01.03.2003 – 28.02.2013	3070063	_____	/each
	1314 (40/92/9) Kaba, R/L, for wicket door	09.07.2001 – 28.02.2013	3070063	_____	/each
	<b>Panic lock</b>			Units	
	1316 (40/92/9/24), PZ, for lever/knob handle set right-hand hinged/left-hand hinged, function E, with lock plate	09.07.2001 – 30.09.2012	3091711	_____	/each
	Without lock plate	09.07.2001 – 28.02.2013	3070273	_____	/each
	1316 (40/92/9/24), KABA, for lever/knob handle set right-hand hinged/left-hand hinged, function E, with lock plate	09.07.2001 – 30.09.2012	3091712	_____	/each
	Without lock plate	01.10.2012 – 28.02.2013	3070274	_____	/each
	1820 (40/92/9), for lever handle set, right-hand hinged, function D, with lock plate	09.07.2001 – 30.06.2012	3091187	_____	/each
	Without lock plate	01.07.2012 – 28.02.2013	3091181	_____	/each
	1820 (40/92/9), for lever handle set, left-hand hinged, function D, with lock plate	09.07.2001 – 30.06.2012	3091184	_____	/each
	Without lock plate	01.07.2012 – 28.02.2013	3091178	_____	/each
	1820 (40/92/9), for lever handle set, right-hand hinged, function B, inwards/outwards with lock plate	09.07.2001 – 30.06.2012	3091185	_____	/each
	Without lock plate	01.07.2012 – 28.02.2013	3091179	_____	/each
	1820 (40/92/9), for lever handle set, left-hand hinged, function B, inwards/outwards with lock plate	09.07.2001 – 30.06.2012	3091182	_____	/each
	Without lock plate	01.07.2012 – 28.02.2013	3091176	_____	/each

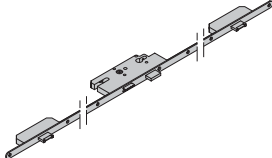
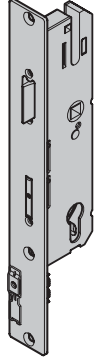
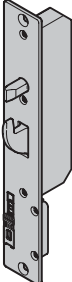

<b>ORDER</b>	Customer no.: _____	Order no./com.: _____	<b>*Please take information from the data label!</b>	
	Customer name: _____	Shipping address: _____	Order no.: _____	Door no.: _____
	Place/date: _____	Stamp and signature _____	Product no.: _____	Type: _____
			Year of manufacture: _____	

## 8. Fitting Parts for Doors

Article	Description	Production period	Art. no.	Qty.	€
	<b>Bolt lock 1308, right/left-hand hinged</b>	01.12.2006 – 28.02.2013	3073251	Units _____	/each
	<b>GU-Secury SH2 3-point locking for side door</b>			Units	
	PC version	03.03.2003 – 28.02.2013	3060386	_____	/each
	KABA version	03.03.2003 – 28.02.2013	3060427	_____	/each
	<b>Main lock multiple-point locking for wicket doors</b>			Units	
	40/92/9 PC, left-hand hinged	12.03.2012 – 28.02.2013	3090620	_____	/each
	40/92/9 PC, right-hand hinged	12.03.2012 – 28.02.2013	3090621	_____	/each
	40/92/9 KABA, left-hand hinged	12.03.2012 – 28.02.2013	3091165	_____	/each
	40/92/9 KABA, right-hand hinged	12.03.2012 – 28.02.2013	3091164	_____	/each
	Panic B, PC, left-hand hinged	12.03.2012 – 28.02.2013	3090622	_____	/each
	Panic B, PC, right-hand hinged	12.03.2012 – 28.02.2013	3090623	_____	/each
	Panic D, PC, left-hand hinged	12.03.2012 – 28.02.2013	3090624	_____	/each
	Panic D, PC, right-hand hinged	12.03.2012 – 28.02.2013	3090625	_____	/each
	Panic E, PC, left-hand hinged	12.03.2012 – 28.02.2013	3090626	_____	/each
	Panic E, PC, right-hand hinged	12.03.2012 – 28.02.2013	3090627	_____	/each
	Panic E, KABA, left-hand hinged	12.03.2012 – 28.02.2013	3091515	_____	/each
	Panic E, KABA, right-hand hinged	12.03.2012 – 28.02.2013	3091516	_____	/each
	Panic B, KABA, left-hand hinged	12.03.2012 – 28.02.2013	3091517	_____	/each
	Panic B, KABA,, right-hand hinged	12.03.2012 – 28.02.2013	3091518	_____	/each
	Panic D, KABA, left-hand hinged	12.03.2012 – 28.02.2013	3091519	_____	/each
Panic D, KABA, right-hand hinged	12.03.2012 – 28.02.2013	3091520	_____	/each	
	<b>Secondary latch multiple-point locking for wicket doors</b>			Units	
	left-hand hinged	12.03.2012 – 28.02.2013	3090628	_____	/each
	right-hand hinged	12.03.2012 – 28.02.2013	3090629	_____	/each



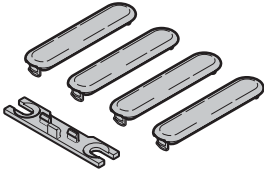
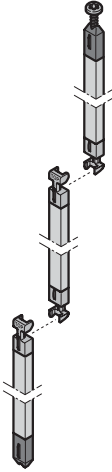
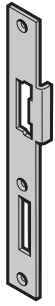

<b>ORDER</b>	Customer no.: _____	Order no./com.: _____	<b>*Please take information from the data label!</b>	
			Order no.: _____	Door no.: _____
	Customer name: _____		Product no.: _____	Type: _____
	Shipping address: _____		Year of manufacture: _____	
	Place/date: _____		Stamp and signature _____	

# 8. Fitting Parts for Doors

Article	Description	Production period	Art. no.	Qty.	€
	<b>Set cover/fitting multiple-point locking for wicket doors</b>	12.03.2012 – 28.02.2013	3090676	Units _____	/each
	<b>Linking rod multiple-point locking for wicket doors</b>  Top Centre Bottom	12.03.2012 – 28.02.2013 12.03.2012 – 28.02.2013 12.03.2012 – 28.02.2013	3091362 3091363 3091364	Units _____ _____ _____	/each /each /each
	<b>Lock plate 92 mm for side door</b>  Left version Right version Countersunk screw M5 x 12, Torx	01.03.2003 – 12.04.2006 01.03.2003 – 12.04.2006	3046873 3046872 4005211	Units _____ _____ _____	/each /each /each
	<b>Lock plate 92 mm for electric door strike model 17E and 27E, side door</b>  Left version Right version Countersunk screw M5 x 12, Torx	01.03.2003 – 12.04.2006 01.03.2003 – 12.04.2006	3050979 3050980 4005211	Units _____ _____ _____	/each /each /each



<b>ORDER</b>	Customer no.: _____	Order no./com.: _____	<b>*Please take information from the data label!</b>	
			Order no.: _____	Door no.: _____
	Customer name: _____		Product no.: _____	Type: _____
	Shipping address: _____		Year of manufacture: _____	
	Place/date: _____		Stamp and signature _____	

## 8. Fitting Parts for Doors

Article	Description	Production period	Art. no.	Qty.	€
	<b>Lock plate 92 mm</b> Wicket door Countersunk screw M5 × 12, Torx	09.07.2001 – 12.04.2006	3053826 4005211	Units _____ _____	/each /each
	<b>Lock plate 92 mm for electric door strike model 17E and 27E</b> Wicket door Countersunk screw M5 × 12, Torx	09.07.2001 – 12.04.2006	3053828 4005211	Units _____ _____	/each /each
	<b>Lock plate 92 mm for wicket door and side door</b> Countersunk screw M4 × 16, Torx	13.04.2006 – 28.02.2013	3070051 3092600	Units _____ _____	/each /each
	<b>Lock plate 92 mm for electric door strike, wicket door and side door</b> Countersunk screw M4 × 16, Torx	01.07.2009 – 28.02.2013	3085995 3092600	Units _____ _____	/each /each

<b>ORDER</b>	Customer no.: _____	Order no./com.: _____	<b>*Please take information from the data label!</b>	
			Order no.:	Door no.:
	Customer name: _____		Product no.:	Type:
	Shipping address: _____		Year of manufacture:	
	Place/date: _____		Stamp and signature	

# 8. Fitting Parts for Doors

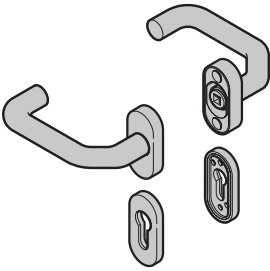
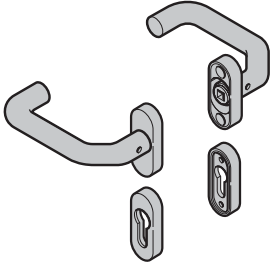
Article	Description	Production period	Art. no.	Qty.	€
	<b>Lock plate for GU-Secury for side door</b> Countersunk screw M4 x 16, Torx	03.03.2003 – 28.02.2013	3059598 3092600	Units _____ _____	/each /each
	<b>Lock plate for bolt lock 1308</b> Countersunk screw M4 x 16, Torx	01.12.2006 – 28.02.2013	3073522 3092600	Units _____ _____	/each /each
	<b>Lock plate for secondary latch</b> Flat-head screw M5 x 10, Torx	12.03.2012 – 28.02.2013	3090619 3064280	Units _____ _____	/each /each
	<b>Lever handle set (92) Offset / offset, black plastic</b> The set does not include a square lever pin, lever / knob pin or panic spindle.  PC KABA	09.07.2001 – 28.02.2013 09.07.2001 – 28.02.2013	3050905 3050906	Units _____ _____	/each /each
	<b>Lever handle set (92) Offset / offset</b> The set does not include a square lever pin, lever / knob pin or panic spindle.  Natural finish cast aluminium F1, PC Natural finish cast aluminium F1, KABA Brushed stainless steel, PC Brushed stainless steel, KABA Polished stainless steel, PC Polished stainless steel, KABA	09.07.2001 – 28.02.2013 09.07.2001 – 28.02.2013 01.03.2003 – 28.02.2013 01.03.2003 – 28.02.2013 09.07.2001 – 28.02.2013 09.07.2001 – 28.02.2013	3053789 3053793 3059622 3059625 3053579 3053554	Units _____ _____ _____ _____ _____ _____	/each /each /each /each /each /each

<b>ORDER</b>	Customer no.: _____	Order no./com.: _____	<b>*Please take information from the data label!</b>	
			Order no.:	Door no.:
	Customer name: _____		Product no.:	Type:
	Shipping address: _____		Year of manufacture: _____	
	Place/date: _____		Stamp and signature _____	

## 8. Fitting Parts for Doors

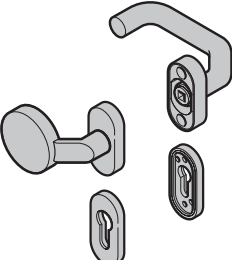
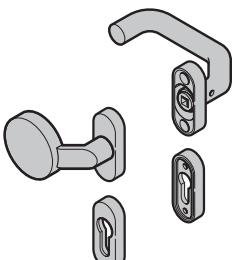
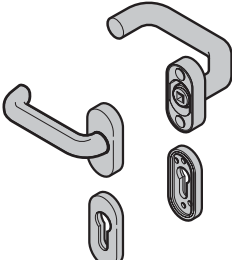
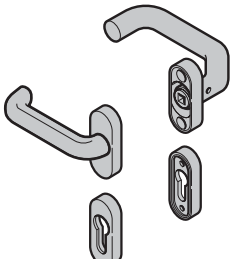
Article	Description	Production period	Art. no.	Qty.	€
	<b>Lever / knob handle set (92) Offset / offset, black plastic</b> The set does not include a square lever pin, lever/knob pin or panic spindle.  PC KABA	09.07.2001 – 28.02.2013	3050745	Units	/each
		09.07.2001 – 28.02.2013	3050909		/each
	<b>Lever / knob handle set (92) Offset / offset</b> The set does not include a square lever pin, lever / knob pin or panic spindle.  Natural finish cast aluminium F1, PC Natural finish cast aluminium F1, KABA Brushed stainless steel, PC Brushed stainless steel, KABA Polished stainless steel, PC Polished stainless steel, KABA	09.07.2001 – 28.02.2013	3053791	Units	/each
		09.07.2001 – 28.02.2013	3053795		/each
		01.03.2003 – 28.02.2013	3059624		/each
		01.03.2003 – 28.02.2013	3059627		/each
		09.07.2001 – 28.02.2013	3053583		/each
		09.07.2001 – 28.02.2013	3053558		/each
	<b>Lever handle set (92) Offset / flat, black plastic</b> The set does not include a square lever pin, lever / knob pin or panic spindle.  PC KABA	09.07.2001 – 28.02.2013	3050966	Units	/each
		09.07.2001 – 28.02.2013	3050972		/each
	<b>Lever handle set (92) Offset / flat</b> The set does not include a square lever pin, lever / knob pin or panic spindle.  Natural finish cast aluminium F1, PC Natural finish cast aluminium F1, KABA Brushed stainless steel, PC Brushed stainless steel, KABA Polished stainless steel, PC Polished stainless steel, KABA	09.07.2001 – 28.02.2013	3053790	Units	/each
		09.07.2001 – 28.02.2013	3053794		/each
		01.03.2003 – 28.02.2013	3059640		/each
		01.03.2003 – 28.02.2013	3059642		/each
		09.07.2001 – 28.02.2013	3053571		/each
		09.07.2001 – 28.02.2013	3053546		/each

<b>ORDER</b>	Customer no.:	Order no./com.:	<b>*Please take information from the data label!</b>	
			Order no.:	Door no.:
	Customer name:		Product no.:	Type:
	Shipping address:		Year of manufacture:	
	Place/date:		Stamp and signature	

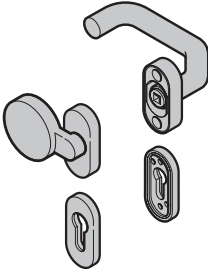
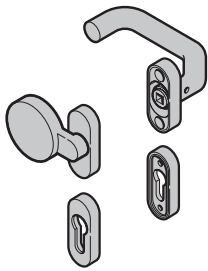
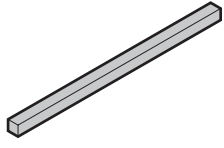
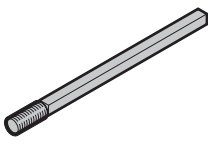
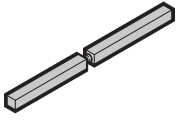

# 8. Fitting Parts for Doors

Article	Description	Production period	Art. no.	Qty.	€
	<b>Lever / knob handle set (92) Offset / flat, black plastic</b> The set does not include a square lever pin, lever / knob pin or panic spindle.			Units	
	PC KABA	09.07.2001 – 28.02.2013 09.07.2001 – 28.02.2013	3050969 3050975	_____ _____	/each /each
	<b>Lever / knob handle set (92) Offset / flat</b> The set does not include a square lever pin, lever / knob pin or panic spindle.			Units	
	Natural finish cast aluminium F1, PC Natural finish cast aluminium F1, KABA	09.07.2001 – 28.02.2013 09.07.2001 – 28.02.2013	3053792 3053796	_____ _____	/each /each
	Brushed stainless steel, PC Brushed stainless steel, KABA	01.03.2003 – 28.02.2013 01.03.2003 – 28.02.2013	3059641 3059643	_____ _____	/each /each
	Polished stainless steel, PC Polished stainless steel, KABA	09.07.2001 – 28.02.2013 09.07.2001 – 28.02.2013	3053575 3053550	_____ _____	/each /each
	<b>Square pin for lever handle, lever / knob handle set</b>			Units	
	L = 110 TS 60, side door / ever handle L = 95 TS 45, wicket door / ever handle	09.07.2001 – 28.02.2013 09.07.2001 – 28.02.2013	3053779 3053786	_____ _____	/each /each
	L = 78 TS 60, side door / lever/knob L = 70 TS 42 - 51 wicket door / lever/knob	23.05.2005 – 28.02.2013 23.05.2005 – 28.02.2013	3065079 3065074	_____ _____	/each /each
	<b>Square lever / knob pin for lever / knob handle set</b>			Units	
	L = 90 TS 45 - 51, wicket door L = 100 TS 60, side door	09.07.2001 – 20.05.2005 09.07.2001 – 20.05.2005	3053780 3053781	_____ _____	/each /each
	<b>Square panic spindle for lever handle set</b>			Units	
	L = 45 - 45, wicket door L = 40 - 65, side door	09.07.2001 – 28.02.2013 09.07.2001 – 28.02.2003	3053333 3053669	_____ _____	/each /each
	L = 45 - 60, side door	01.03.2003 – 28.02.2013	3059750	_____	/each

<b>ORDER</b>	Customer no.:	Order no./com.:	<b>*Please take information from the data label!</b>	
			Order no.:	Door no.:
	Customer name:		Product no.:	Type:
	Shipping address:	Year of manufacture:		
	Place/date:	Stamp and signature		

## 8. Fitting Parts for Doors

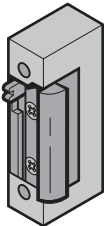
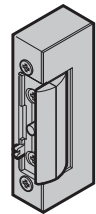
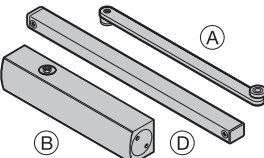
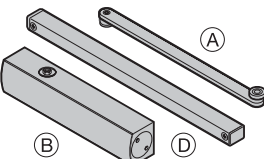
Article	Description	Production period	Art. no.	Qty.	€
	<b>Electric door strike</b> 17E, 6-12 V Only opens with an impulse, i.e. as long as the button is pressed	09.07.2001 – 12.04.2006	3050919	Units	/each
	17E, 24 V Only opens with an impulse, i.e. as long as the button is pressed	01.03.2004 – 12.04.2006	3060435	_____	/each
	27E, 6-12 V Remains open after impulse until the door is actuated	01.03.2004 – 12.04.2006	3060436	_____	/each
	27E, 24 V Remains open after impulse until the door is actuated	01.03.2004 – 12.04.2006	3060437	_____	/each
	<b>Electric door strike</b> 118E, 10-24 V, operating current Only opens with an impulse, i.e. as long as the button is pressed With lock plate (if LT611E is being used)	13.04.2006 – 30.06.2009	3085996	Units	/each
	Without lock plate	01.07.2009 –	3085993	_____	/each
	128E, 10-24 V, lock Remains open after impulse until the door is actuated With lock plate (if LT611E is being used)	13.04.2006 – 30.06.2009	3085997	_____	/each
	Without lock plate	01.07.2009 –	3085994	_____	/each
	<b>Door closer</b> TS 5000 cpl. with slide rail for side door	01.03.2003 – 31.01.2007	3053242	Units	/each
	TS 5000 without linkage (B)	01.03.2003 – 31.01.2007	3053244	_____	/each
	Lever with slide rail (A)+(D) for side door	01.03.2003 – 31.01.2007	3053245	_____	/each
	<b>Door closer</b> TS 5000S with cpl. closing delay with slide rail for side door	01.03.2003 – 31.01.2007	3059745	Units	/each
	TS 5000S without linkage (B)	01.03.2003 – 31.01.2007	3059677	_____	/each
	Lever with slide rail (A)+(D) for side door	01.03.2003 – 31.01.2007	3053245	_____	/each
	Hebel mit Rolle (A) für Schlupftür	01.03.2003 – 31.01.2007	3059676	_____	/each

<b>ORDER</b>	Customer no.:	Order no./com.:	<b>*Please take information from the data label!</b>	
			Order no.:	Door no.:
	Customer name:		Product no.:	Type:
	Shipping address:		Year of manufacture:	
	Place/date:		Stamp and signature	

# 8. Fitting Parts for Doors

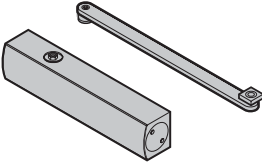
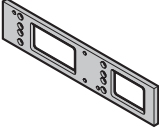
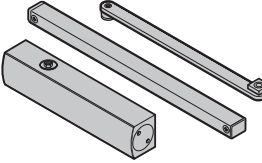
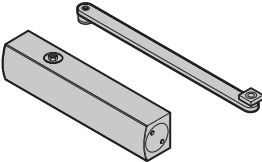
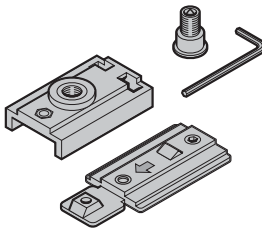
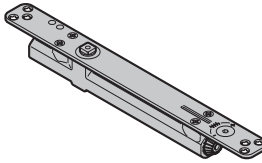
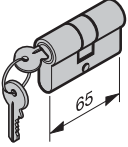
Article	Description	Production period	Art. no.	Qty.	€
	<b>Door closer</b>			Units	
	TS 4000 without linkage	07.05.2004 – 31.01.2007	3064286	_____	/each
	Lever with roller for wicket door	01.05.2000 – 06.05.2004	3044982	_____	/each
	Lever with roller for wicket door	07.05.2004 – 31.01.2007	3064287	_____	/each
	<b>Door closer base plate for TS 4000/5000 with fixing set for side door and wicket door</b>	09.07.2001 – 28.02.2013	3021165	Units	/each
	<b>Cpl. door closer for side door</b>			Units	
	TS 33	01.02.2007 – 28.02.2013	3093392	_____	/each
	TS 41	01.02.2007 – 28.02.2013	3093393	_____	/each
	<b>Door closer TS 33-G, incl. opening limiter for wicket door</b>	01.02.2007 – 28.02.2013	3093394	Units	/each
	<b>Hold-open device for TSO 400/500</b>	01.02.2007 – 28.02.2013	3073400	Units	/each
	<b>Integrated door closer</b>			Units	
	ITS 96	01.03.2012 – 28.02.2013	3090749	_____	/each
	Fitting element	01.03.2012 – 28.02.2013	3090752	_____	/each
	Grid hold-open unit	01.03.2012 – 28.02.2013	3090753	_____	/each
	Slide rail left	01.03.2012 – 28.02.2013	3090750	_____	/each
	Slide rail right	01.03.2012 – 28.02.2013	3090751	_____	/each
	<b>Profile cylinder for wicket door, keys to differ 35 + 30 mm</b>	09.07.2001 – 28.02.2013	3091446	Units	/each

<b>ORDER</b>	Customer no.: _____	Order no./com.: _____	<b>*Please take information from the data label!</b>	
			Order no.: _____	Door no.: _____
	Customer name: _____		Product no.: _____	Type: _____
	Shipping address: _____		Year of manufacture: _____	
	Place/date: _____		Stamp and signature _____	

## 8. Fitting Parts for Doors

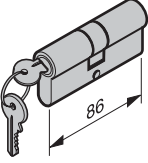
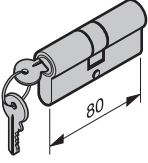
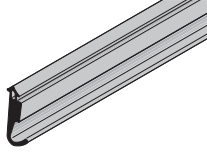
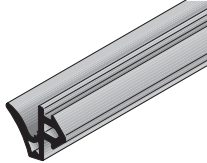
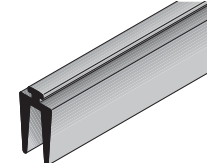
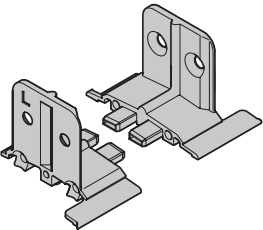
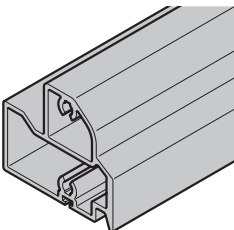
Article	Description	Production period	Art. no.	Qty.	€
	<b>Profile cylinder for side door, keys to differ, 55.5 + 31.5 mm</b>	09.07.2001 – 28.02.2003	3043300	Units _____	/each
	<b>Profile cylinder for side door, keys to differ 45 + 35 mm</b>	01.03.2003 – 28.02.2013	3059751	Units _____	/each
	<b>Door seal, side</b> Length _____ mm	09.07.2001 – 28.02.2003	3046482	Units _____	/m
	<b>Door seal, side</b> Length _____ mm	01.03.2003 – 28.02.2013	3055166	Units _____	/m
	<b>Door seal, bottom</b> Length _____ mm	09.07.2001 – 28.02.2013	3046470	Units _____	/m
	<b>Threshold connector for side door</b> Left Right	03.03.2003 – 28.02.2013 03.03.2003 – 28.02.2013	3059565 3059566	Units _____ _____	/each /each
	<b>Bottom profile for side door</b> Length _____ mm	03.03.2003 – 28.02.2013	3085751	Units _____	/m

<b>ORDER</b>	Customer no.: _____	Order no./com.: _____	<b>*Please take information from the data label!</b>	
	Customer name: _____	Shipping address: _____	Order no.: _____	Door no.: _____
	Place/date: _____	Stamp and signature _____	Product no.: _____	Type: _____
			Year of manufacture: _____	

# 8. Fitting Parts for Doors

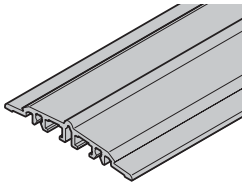
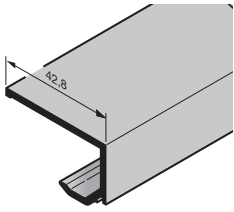
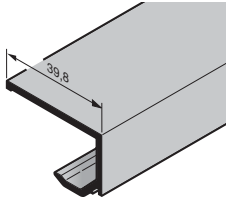
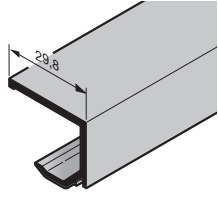
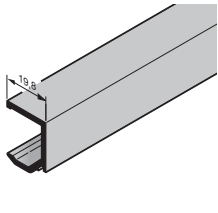
Article	Description	Production period	Art. no.	Qty.	€
	<b>Threshold profile for side door</b> Length _____ mm	03.03.2003 – 28.02.2013	3072422	Units _____	/m
	<b>Aluminium glazing bead for side door NTP040, Infill thickness 3 mm, anodised (max 6000 mm)</b> E6/EV1, length _____ mm Surcharge for painted glazing bead based on RAL _____ E6/C35, length _____ mm	03.03.2003 – 28.02.2013  02.02.2009 – 28.02.2013	3085558  3089802 3085559	Units _____ _____ _____	/m  /m /m
	<b>Aluminium glazing bead for side door NTP039, Infill thickness 6 mm, anodised (max 6000 mm)</b> E6/EV1, length _____ mm Surcharge for painted glazing bead based on RAL _____ E6/C35, length _____ mm	03.03.2003 – 28.02.2013  02.02.2009 – 28.02.2013	3085556  3089802 3085557	Units _____ _____ _____	/m  /m /m
	<b>Aluminium glazing bead for side door NTP038, Infill thickness 16 mm, anodised (max 6000 mm)</b> E6/C35, length _____ mm	02.02.2009 – 28.02.2013	3085555	Units _____	/m
	<b>Aluminium glazing bead for side door NTP037, Infill thickness 26 mm, anodised (max 6000 mm)</b> E6/EV1, length _____ mm Surcharge for painted glazing bead based on RAL _____ E6/C35, length _____ mm	03.03.2003 – 28.02.2013  02.02.2009 – 28.02.2013	3085553  3089802 3085554	Units _____ _____ _____	/m  /m /m

<b>ORDER</b>	Customer no.: _____	Order no./com.: _____	<b>*Please take information from the data label!</b>	
	Customer name: _____	Shipping address: _____	Order no.: _____	Door no.: _____
	Place/date: _____	Stamp and signature _____	Product no.: _____	Type: _____
			Year of manufacture: _____	

# 8. Fitting Parts for Doors

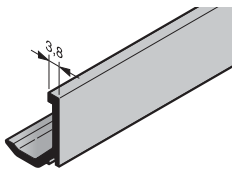
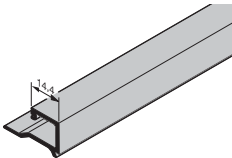
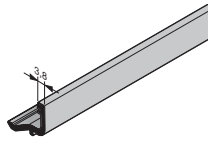
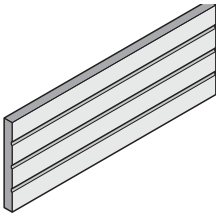
Article	Description	Production period	Art. no.	Qty.	€
	<b>Aluminium glazing bead for side door NTP036, Infill thickness 42 mm, anodised (max 6000 mm)</b> E6/EV1, length _____ mm Surcharge for painted glazing bead based on RAL _____ E6/C35, length _____ mm	03.03.2003 – 28.02.2013	3065926	Units _____	/m
			3089802	_____	/m
			02.02.2009 – 28.02.2013	3085552	_____
	<b>Aluminium glazing bead for side door ASP40 / ASR40 / NTP079, Infill thickness 26 mm, anodised (max 6000 mm)</b> E6/EV1, length _____ mm Surcharge for painted glazing bead based on RAL _____ E6/C35, length _____ mm	01.07.2009 – 28.02.2013	3086469	Units _____	/m
			3089802	_____	/m
			01.07.2009 – 28.02.2013	3086470	_____
	<b>Aluminium glazing bead for side door ASP40 / NTP076, Infill thickness 42 mm, anodised (max 6000 mm)</b> E6/EV1, length _____ mm Surcharge for painted glazing bead based on RAL _____ E6/C35, length _____ mm	01.07.2009 – 28.02.2013	3086471	Units _____	/m
			3089802	_____	/m
			01.07.2009 – 28.02.2013	3086472	_____
	<b>Section infill</b>	09.07.2001 – 28.02.2013	3090648	Units _____	/m <sup>2</sup>

<b>ORDER</b>	Customer no.: _____	Order no./com.: _____	<b>*Please take information from the data label!</b>	
	Customer name: _____	Shipping address: _____	Order no.: _____	Door no.: _____
	Place/date: _____	Stamp and signature _____	Product no.: _____	Type: _____
			Year of manufacture: _____	

# 9. General Accessories

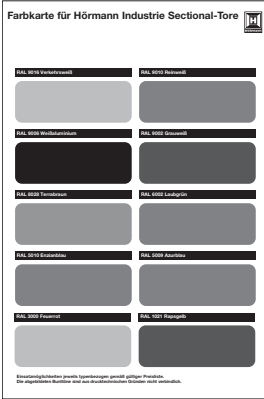
Article	Description	Production period	Art. no.	Qty.	€
	<b>Polyester-primer coating in preferred colours</b> (coil coating)  Exterior in preferred colour, interior in Grey white based on RAL 9002 for: <ul style="list-style-type: none"> <li>• Door sections SPU 40</li> <li>• Bottom section APU 40/TAP 40</li> </ul>			Units	
					
	Based on RAL 3000 Flame red	09.07.2001 – 28.02.2013	3054340	_____	+0
	Based on RAL 5010 Gentian blue	09.07.2001 – 28.02.2013	3054342	_____	+0
	Based on RAL 6005 Moss green	01.06.2005 – 28.02.2013	3065023	_____	+0
	Based on RAL 7016 Anthracite grey	01.06.2005 – 28.02.2013	3065024	_____	+0
	Based on RAL 8028 Terra brown	09.07.2001 – 28.02.2013	3054344	_____	+0
	Based on RAL 9002 Grey white	09.07.2001 – 28.02.2013	3054345	_____	+0
	Based on RAL 9006 White aluminium	09.07.2001 – 28.02.2013	3054346	_____	+0
	Based on RAL 9007 Grey aluminium	01.06.2006 – 28.02.2013	3072878	_____	+0
	Based on RAL 9010 Pure white	09.07.2001 – 28.02.2013	3054347	_____	+0
	Based on RAL 9016 Traffic white	09.07.2001 – 28.02.2013	3054348	_____	+0

+<sup>0</sup> No surcharge

+<sup>3</sup> Surcharges for fascias in Color and RAL to choose, see page 136 / indicate colour article number.

+<sup>4</sup> Surcharge for infill colour, see page 136

F = per field

**Note:** The minimum order quantities in brackets must be taken into account for screws, nuts etc.!

<b>ORDER</b>	Customer no.: _____	Order no./com.: _____	<b>*Please take information from the data label!</b>	
			Order no.:	Door no.:
	Customer name: _____		Product no.:	Type:
	Shipping address: _____		Year of manufacture:	
	Place/date: _____		Stamp and signature	

# 9. General Accessories

Article	Description	Production period	Art. no.	Qty.	€
	<p><b>Polyester-primer coating based on the RAL colour chart</b> (wet coating)</p> <p>Exterior based on the RAL colour chart, interior Grey white, based on RAL 9002 for:</p> <ul style="list-style-type: none"> <li>• PU-foamed door sections</li> </ul>	09.07.2001 – 28.02.2013	3056218	Units	/m <sup>2</sup>
	<p><b>Polyester-primer coating in preferred colours</b> (wet coating)</p> <p>Exterior and interior in preferred colour for:</p> <ul style="list-style-type: none"> <li>• Single-skinned door sections or PU-foamed door sections</li> <li>• Door sections as an aluminium frame (with exception of clamping profile)</li> <li>• Bottom infill with ALR 40 and TAR 40</li> <li>• Expanded mesh</li> </ul>				
	Based on RAL 1021 Rape yellow	09.07.2001 – 28.02.2013	3054349	_____	/m <sup>2</sup>
	Based on RAL 3000 Flame red	09.07.2001 – 28.02.2013	3054350	_____	/m <sup>2</sup>
	Based on RAL 5002 Ultramarine blue	01.06.2006 – 28.02.2013	3072879	_____	/m <sup>2</sup>
	Based on RAL 5009 Azure blue	09.07.2001 – 28.02.2013	3054351	_____	/m <sup>2</sup>
	Based on RAL 5010 Gentian blue	09.07.2001 – 28.02.2013	3054352	_____	/m <sup>2</sup>
	Based on RAL 6002 Leaf green	09.07.2001 – 28.02.2013	3054353	_____	/m <sup>2</sup>
	Based on RAL 6005 Moss green	01.06.2005 – 28.02.2013	3065025	_____	/m <sup>2</sup>
	Based on RAL 7016 Anthracite grey	01.06.2005 – 28.02.2013	3065026	_____	/m <sup>2</sup>
	Based on RAL 8028 Terra brown	09.07.2001 – 28.02.2013	3056238	_____	/m <sup>2</sup>
	Based on RAL 9002 Grey white	09.07.2001 – 28.02.2013	3054354	_____	/m <sup>2</sup>
	Based on RAL 9006 White aluminium	09.07.2001 – 28.02.2013	3054355	_____	/m <sup>2</sup>
	Based on RAL 9007 Grey aluminium	01.06.2006 – 28.02.2013	3072880	_____	/m <sup>2</sup>
	Based on RAL 9010 Pure white	09.07.2001 – 28.02.2013	3054356	_____	/m <sup>2</sup>
	Based on RAL 9016 Traffic white	09.07.2001 – 28.02.2013	3056239	_____	/m <sup>2</sup>
	Polyester-primer coating in RAL to choose	09.07.2001 – 28.02.2013	3045134	_____	/m <sup>2</sup>

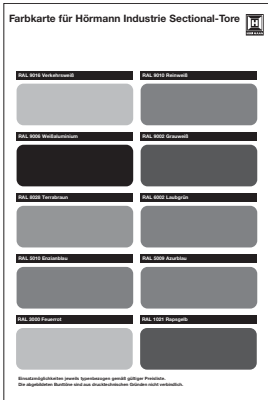

+<sup>0</sup> No surcharge

+<sup>3</sup> Surcharges for fascias in Color and RAL to choose, see page 136 / indicate colour article number.

+<sup>4</sup> Surcharge for infill colour, see page 136



F = per field

**Note:** The minimum order quantities in brackets must be taken into account for screws, nuts etc.!

<b>ORDER</b>	Customer no.:	Order no./com.:	<b>*Please take information from the data label!</b>	
	Customer name:		Order no.:	Door no.:
	Shipping address:		Product no.:	Type:
			Year of manufacture:	
	Place/date:		Stamp and signature	



# 9. General Accessories

Article	Description	Production period	Art. no.	Qty.	€	
	<b>Touch-up pen</b> Based on RAL 1021 Rape yellow Based on RAL 3000 Flame red Based on RAL 5002 Ultramarine blue Based on RAL 5009 Azure blue Based on RAL 5010 Gentian blue Based on RAL 6002 Leaf green Based on RAL 6005 Moss green Based on RAL 7016 Anthracite grey Based on RAL 8028 Terra brown Based on RAL 9002 Grey white Based on RAL 9006 White aluminium Based on RAL 9007 Grey aluminium Based on RAL 9010 Pure white Based on RAL 9016 Traffic white RAL to choose		3083713 3083732 3083764 3083770 3083771 3083787 3083790 3083831 3083873 3083877 3083881 3083882 3083883 3083885 3080067	Units _____ _____ _____ _____ _____ _____ _____ _____ _____ _____ _____ _____ _____ _____	/each /each /each /each /each /each /each /each /each /each /each /each /each /each /each	
		<b>Polyester-primer coating in a tin (1 kg)</b> Based on preferred colour _____ RAL to choose _____		3094155 3061835	Units _____ _____	/each /each
		<b>Single-skinned steel fascia with fitting accessories to make up for insufficient headroom: 31 – 125 mm</b> Stucco Smooth Based on RAL _____	09.07.2007 – 28.02.2013 01.02.2009 – 28.02.2013	3045553 3085362 _____	Units _____ _____ _____	/m /m + <sup>3</sup>

+<sup>0</sup> No surcharge

+<sup>3</sup> Surcharges for fascias in Color and RAL to choose, see page 136 / indicate colour article number.

+<sup>4</sup> Surcharge for infill colour, see page 136

F = per field

**Note:** The minimum order quantities in brackets must be taken into account for screws, nuts etc.!

<b>ORDER</b>	Customer no.: _____	Order no./com.: _____	<b>*Please take information from the data label!</b>	
	Customer name: _____	Shipping address: _____	Order no.: _____	Door no.: _____
	Place/date: _____	Stamp and signature _____	Product no.: _____	Type: _____
			Year of manufacture: _____	

# 9. General Accessories

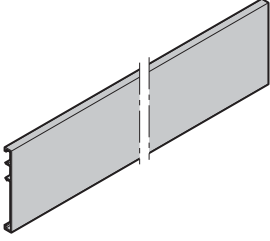
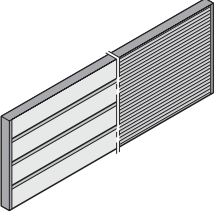
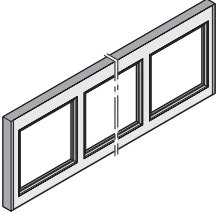
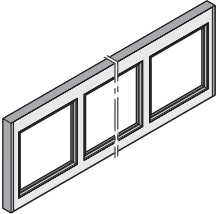
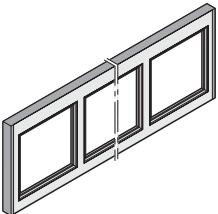
Article	Description	Production period	Art. no.	Qty.	€
	<b>Smooth aluminium panel, anodised, to make up for insufficient headroom: 31 – 190 mm</b>  Height: 200 mm Based on RAL _____	09.07.2007 – 28.02.2013	3046548	Units _____	/m + <sup>3</sup>
	<b>Double-skinned fascia panel</b>  S-ribbed, Stucco, ≤ 250 mm S-ribbed, Stucco, > 250 mm L-ribbed, Micrograin, ≤ 250 mm L-ribbed, Micrograin, > 250 mm Based on RAL _____	09.07.2007 – 28.02.2013 09.07.2007 – 28.02.2013 01.02.2009 – 28.02.2013 01.02.2009 – 28.02.2013	3091651 3091652 3091653 3091654	Units _____ _____ _____ _____	/m <sup>2</sup> /m <sup>2</sup> /m <sup>2</sup> /m <sup>2</sup> + <sup>3</sup>
	<b>Aluminium fascia panel NF type N, anodised</b>  Based on RAL _____ Infill _____ Infill based on RAL _____ Surcharge for aluminium glazing beads Surcharge for painted glazing beads	09.07.2007 – 28.02.2013	3080043   3087577 3087576	Units _____ _____ _____ _____ _____	/m <sup>2</sup> + <sup>3</sup> + <sup>3</sup> + <sup>4</sup> /F /F
	<b>Aluminium fascia panel NF type B, anodised</b>  Based on RAL _____ Infill _____ Infill based on RAL _____ Surcharge for aluminium glazing beads Surcharge for painted glazing beads	09.07.2007 – 28.02.2013	3080044   3087577 3087576	Units _____ _____ _____ _____ _____	/m <sup>2</sup> + <sup>3</sup> + <sup>3</sup> + <sup>4</sup> /F /F
	<b>Aluminium fascia profile WF, anodised</b>  Based on RAL _____ Infill _____ Infill based on RAL _____ Surcharge for aluminium glazing beads Surcharge for painted glazing beads	09.07.2007 – 28.02.2013	3080045   3087577 3087576	Units _____ _____ _____ _____ _____	/m <sup>2</sup> + <sup>3</sup> + <sup>3</sup> + <sup>4</sup> /F /F

+<sup>0</sup> No surcharge

+<sup>3</sup> Surcharges for fascias in Color and RAL to choose, see page 136/indicate colour article number.





+<sup>4</sup> Surcharge for infill colour, see page 136

F = per field

**Note:** The minimum order quantities in brackets must be taken into account for screws, nuts etc.!

<b>ORDER</b>	Customer no.: _____	Order no./com.: _____	<b>*Please take information from the data label!</b>	
			Order no.:	Door no.:
	Customer name: _____		Product no.:	Type:
	Shipping address: _____		Year of manufacture:	
	Place/date: _____		Stamp and signature	

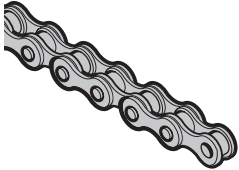
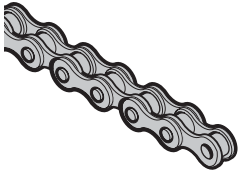
# 9. General Accessories

Article	Description	Production period	Art. no.	Qty.	€
	<b>* Cable, Ø 4 mm, for cable drums</b> Size 1, 6 incl. eyelet and ferrule Track application N, V incl. terminal Track application L, LD	09.07.2001 – 28.02.2013	3094620	Units _____	/m
		09.07.2001 – 28.02.2013	3094621	Units _____	/m
	<b>* Cable, Ø 5.5 mm for cable drums</b> Size 2, 3, 4, 5, 7, 8 incl. eyelet and ferrule Track applications N, H, V incl. terminal Track application L, LD	09.07.2001 – 28.02.2013	3094622	Units _____	/m
		09.07.2001 – 28.02.2013	3094623	Units _____	/m
	<b>* Cable Ø 7 mm with eyelet for depth 80 with direct drive operator</b>	01.06.2006 – 28.02.2013	3072407	Units _____	/m
	<b>* Single roller chain, ISO 83, for cable, Ø 4 mm, track application L, LD</b> Connecting link with spring clip	09.07.2001 – 28.02.2013	3076908	Units _____	/m
		14.03.2008 – 28.02.2013	3076617	Units _____	/each
	<b>* Single roller chain, ISO 84, for cable, Ø 5.5 mm, track application L, LD</b> Connecting link with spring clip for roller chain ISO 84	09.07.2001 – 28.02.2013	3056035	Units _____	/m
		09.07.2001 – 28.02.2013	3055170	Units _____	/each
	<b>Cable slack device type N</b>	09.07.2001 – 28.02.2013	3040918	Units _____	/each

+<sup>0</sup> No surcharge

+<sup>3</sup> Surcharges for fascias in Color and RAL to choose, see page 136 / indicate colour article number.



+<sup>4</sup> Surcharge for infill colour, see page 136

F = per field

**Note:** The minimum order quantities in brackets must be taken into account for screws, nuts etc.!

<b>ORDER</b>	Customer no.: _____	Order no./com.: _____	<b>*Please take information from the data label!</b>	
			Order no.: _____	Door no.: _____
	Customer name: _____		Product no.: _____	Type: _____
	Shipping address: _____		Year of manufacture: _____	
	Place/date: _____		Stamp and signature _____	

# 9. General Accessories

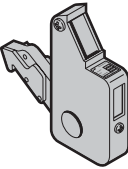
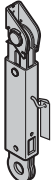
Article	Description	Production period	Art. no.	Qty.	€
	<b>Cable slack device type H, V</b>	09.07.2001 – 28.02.2013	3040919	Units _____	/each
	<b>Catch safety device type N</b>	09.07.2001 – 28.02.2013	3040916	Units _____	/each
	<b>Catch safety device type H, V</b>	09.07.2001 – 28.02.2013	3040917	Units _____	/each
	<b>Catch safety device, cable slack device type L</b>	09.07.2001 – 28.02.2013	3054778	Units _____	/each
	<b>Anti-lift kit type N cpl.</b>	01.07.2001 – 28.02.2013	3054891	Units _____	/each
	<b>Anti-lift kit type H, V cpl.</b>	01.07.2001 – 28.02.2013	3054892	Units _____	/each

+<sup>0</sup> No surcharge

+<sup>3</sup> Surcharges for fascias in Color and RAL to choose, see page 136/indicate colour article number.





+<sup>4</sup> Surcharge for infill colour, see page 136

F = per field

**Note:** The minimum order quantities in brackets must be taken into account for screws, nuts etc.!

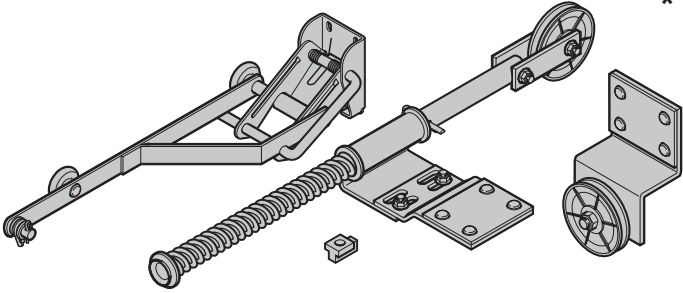
<b>ORDER</b>	Customer no.: _____	Order no./com.: _____	<b>*Please take information from the data label!</b>	
			Order no.:	Door no.:
	Customer name: _____		Product no.:	Type:
	Shipping address: _____		Year of manufacture:	
	Place/date: _____		Stamp and signature	

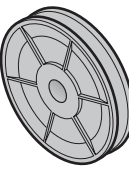
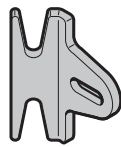
# 9. General Accessories

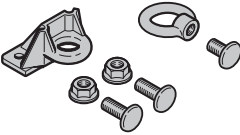
Article	Description	Production period	Art. no.	Qty.	€
	<b>Cable safety device accessories</b> Track application N3	09.07.2001 – 28.02.2013	3094707	Units	/each
	* <b>Cable, Ø 3 mm for cable safety device</b>	09.07.2001 – 28.02.2013	3042454	Units	/m
	<b>Cable return pulley, Ø 78 mm</b> Tallow-drop screw M10 x 30 with hexagon socket and locking paint Hex nut M10 with flange and head teeth	09.07.2001 – 28.02.2013	3047251 3054147 3054148	Units	/each /each /each
	<b>Rope and chain holder</b> Round-head screw M8 x 16 Hex nut M8 with hollow flange	09.07.2001 –	3025357 3043208 3018270	Units	/each /each /each
	<b>Pull rope Ø 12 mm</b> Length _____ mm	09.07.2001 –	3045659	Units	/m
	<b>Pull rope accessories</b>	09.07.2001 –	3056437	Units	/each

+<sup>0</sup> No surcharge

+<sup>3</sup> Surcharges for fascias in Color and RAL to choose, see page 136 / indicate colour article number.



+<sup>4</sup> Surcharge for infill colour, see page 136

F = per field

**Note:** The minimum order quantities in brackets must be taken into account for screws, nuts etc.!

<b>ORDER</b>	Customer no.: _____	Order no./com.: _____	<b>*Please take information from the data label!</b>	
			Order no.:	Door no.:
	Customer name: _____		Product no.:	Type:
	Shipping address: _____		Year of manufacture:	
	Place/date: _____		Stamp and signature	

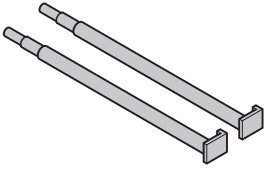
# 9. General Accessories

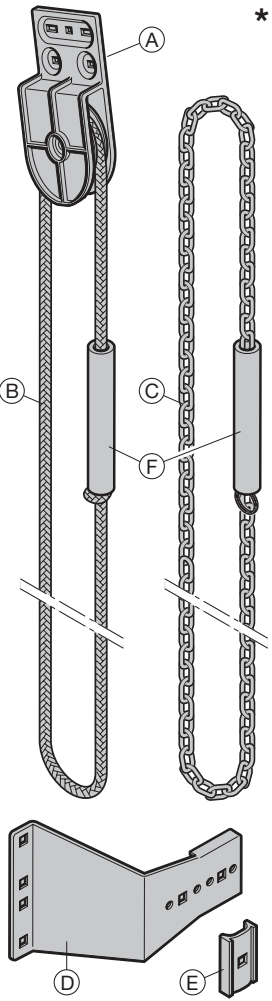
Article	Description	Production period	Art. no.	Qty.	€
	<b>Tensioning and adjustment lever for profile tube (2 x)</b>	09.07.2001 –	3043385	Units _____	/each
	<b>Company sign, blue / orange 260 x 50 x 3 mm</b>	09.07.2001 –	3055436	Units _____	/each
	<b>* Complete hand pulley</b>			Units	
	With pull rope (track application N, H)	09.07.2001 – 28.02.2013	3044775	_____	/each
	With pull rope (track application V, VU)	09.07.2001 – 28.02.2013	3044460	_____	/each
	With link steel chain (track application N, H)	09.07.2001 – 28.02.2013	3045172	_____	/each
	With link steel chain (track application V, VU)	09.07.2001 – 28.02.2013	3045171	_____	/each
	(A) Hand pulley housing	09.07.2001 – 28.02.2013	3024474	_____	/each
	Flat-head screw M8 x 22		3035719	_____	/each
	Hex nut M8 with hollow flange		3018270	_____	/each
	(B) Pull rope Ø 12 mm Length _____ mm	09.07.2001 – 28.02.2013	3045659	_____	/m
	(C) Link steel chain A5 – DIN 766 Length _____ mm	09.07.2001 – 28.02.2013	3045668	_____	/m
(D) Retaining angle N, H, V, VU Galvanized Stainless steel	09.07.2001 – 28.02.2013 01.10.2007 – 28.02.2013	3043232 3074727	_____ _____	/each /each	
(E) Clamp for pull rope Round-head screw M6 x 25 Hex nut M6	09.07.2001 – 28.02.2013	3024814 3024954 3001660	_____ _____ _____	/each /each /each	
(F) Galvanized hand pulley weight	09.07.2001 – 28.02.2013	3024466	_____	/each	

+<sup>0</sup> No surcharge

+<sup>3</sup> Surcharges for fascias in Color and RAL to choose, see page 136 / indicate colour article number.

+<sup>4</sup> Surcharge for infill colour, see page 136

F = per field

**Note:** The minimum order quantities in brackets must be taken into account for screws, nuts etc.!

<b>ORDER</b>	Customer no.:	Order no./com.:	<b>*Please take information from the data label!</b>	
	Customer name:	Shipping address:	Order no.:	Door no.:
	Place/date:		Product no.:	Type:
			Year of manufacture:	
			Stamp and signature	

# 9. General Accessories

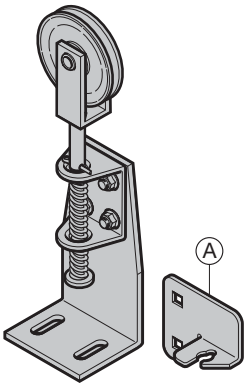
Article	Description	Production period	Art. no.	Qty.	€
	<b>Complete chain tensioner for link steel chain HKZ</b>			Units	
	Left	01.03.2003 – 28.02.2013	3059683	_____	/each
	Right	01.03.2003 – 28.02.2013	3059684	_____	/each
	(A) Chain holder, left	01.03.2003 – 28.02.2013	3053856	_____	/each
	(A) Chain holder, right	01.03.2003 – 28.02.2013	3053857	_____	/each

+<sup>0</sup> No surcharge

+<sup>3</sup> Surcharges for fascias in Color and RAL to choose, see page 136 / indicate colour article number.

+<sup>4</sup> Surcharge for infill colour, see page 136

F = per field

**Note:** The minimum order quantities in brackets must be taken into account for screws, nuts etc.!

<b>ORDER</b>	Customer no.: _____ Order no./com.: _____	<b>*Please take information from the data label!</b>	
	Customer name: _____	Order no.: _____	Door no.: _____
	Shipping address: _____	Product no.: _____	Type: _____
	Place/date: _____	Year of manufacture: _____	
		Stamp and signature _____	



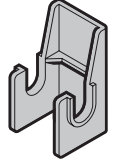
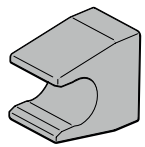
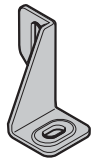
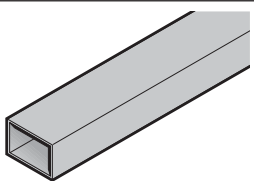
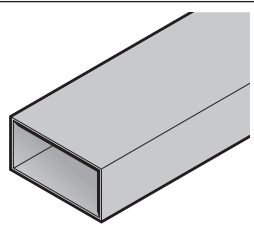

# 9. General Accessories

Article	Description	Production period	Art. no.	Qty.	€
	<b>Pull rod</b> Length depending on door height	09.07.2001 – 28.02.2013	3021246	Units _____	/m
	<b>Holder for pull rod</b>	09.07.2001 – 28.02.2013	3005321	Units _____	/each
	<b>Retaining clip linking bar for operator doors emergency operation</b>	09.07.2001 – 28.02.2013	3072230	Units _____	/each
	<b>Screw-on anchor set</b> (10 right, 10 left)	01.07.2001 – 28.02.2013	3043776	Units _____	/each
	<b>Tube 40 x 60 x 2 mm, hot-galvanized</b> Length _____ mm unfinished, 6980 mm long		3046488 3088560	Units _____ _____	/m /each
	<b>Tube 120 x 60 x 2 mm, hot-galvanized</b> Length _____ mm unfinished, 6980 mm long		3046490 3082307	Units _____ _____	/m /each

+<sup>0</sup> No surcharge

+<sup>3</sup> Surcharges for fascias in Color and RAL to choose, see page 136 / indicate colour article number.

+<sup>4</sup> Surcharge for infill colour, see page 136

F = per field

**Note:** The minimum order quantities in brackets must be taken into account for screws, nuts etc.!

<b>ORDER</b>	Customer no.: _____	Order no./com.: _____	<b>*Please take information from the data label!</b>	
	Customer name: _____	Shipping address: _____	Order no.: _____	Door no.: _____
	Place/date: _____	Stamp and signature _____	Product no.: _____	Type: _____
			Year of manufacture: _____	

# 9. General Accessories

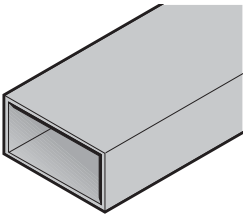
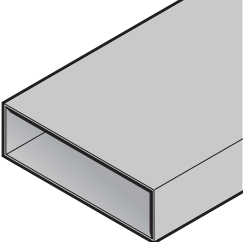
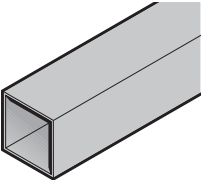
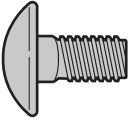
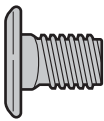
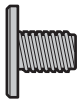
Article	Description	Production period	Art. no.	Qty.	€
	<b>Tube 120 x 60 x 3 mm, hot-galvanized</b> Length _____ mm unfinished, 8000 mm long		3042358 3082388	Units _____ _____	/m /each
	<b>Tube 200 x 60 x 2.5 mm, hot-galvanized</b> Length _____ mm unfinished, 6980 mm long		3046681 3081993	Units _____ _____	/m /each
	<b>Tube 60 x 60 x 2 mm, hot-galvanized</b> Length _____ mm unfinished, 8000 mm long		3042021 3094115	Units _____ _____	/m /each
	<b>Round-head screw (20 screws)</b> M6 x 14 M6 x 14, stainless steel M6 x 16 M6 x 19.5 M6 x 25 M8 x 16 M8 x 22 M8 x 25 M10 x 20		3086084 3073210 3001431 3001440 3024954 3006980 3035719 3043236 3043210	Units _____ _____ _____ _____ _____ _____ _____ _____ _____	/each /each /each /each /each /each /each /each /each
	<b>Flat-head screw (50)</b> M8 x 13 M8 x 16		3043106 3043208	Units _____ _____	/each /each
	<b>Torx flat-head screw (20)</b> M5 x 10, Geomet		3064280	Units _____	/each

+<sup>0</sup> No surcharge

+<sup>3</sup> Surcharges for fascias in Color and RAL to choose, see page 136/indicate colour article number.



+<sup>4</sup> Surcharge for infill colour, see page 136

F = per field

**Note:** The minimum order quantities in brackets must be taken into account for screws, nuts etc.!

<b>ORDER</b>	Customer no.:	Order no./com.:	<b>*Please take information from the data label!</b>	
			Order no.:	Door no.:
	Customer name:		Product no.:	Type:
	Shipping address:		Year of manufacture:	
	Place/date:		Stamp and signature	

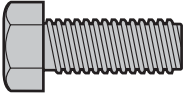
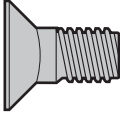
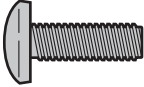
# 9. General Accessories

Article	Description	Production period	Art. no.	Qty.	€
	<b>Hexagon screw</b> (20)			Units	
	M8 × 20		3001512	_____	/each
	M8 × 25		3016153	_____	/each
	M8 × 30		3001520	_____	/each
	M8 × 75		3030539	_____	/each
	M10 × 20		3001555	_____	/each
	M10 × 20 with cup point		3011224	_____	/each
	<b>Countersunk screw</b> (20)			Units	
	M5 × 12, Torx		4005211	_____	/each
	M5 × 45, with cross recess		3060480	_____	/each
	M8 × 17, with square neck		3001717	_____	/each
	<b>Tallow-drop screw</b> (10)			Units	
	3 × 18 with cross recess		3063037	_____	/each
	4 × 12 with Torx, stainless steel		3064279	_____	/each
	M8 × 25		3041446	_____	/each
	M8 × 40		3041409	_____	/each
	M8 × 45		3055036	_____	/each
	M8 × 50		3045689	_____	/each
	M8 × 65		3041408	_____	/each
	<b>Split pin</b> (10)			Units	
	4 × 18, galvanized		3024784	_____	/each
	4 × 18, stainless steel		3090233	_____	/each
	4 × 28, galvanized		3001865	_____	/each
	4 × 28, stainless steel		3090263	_____	/each
	<b>Hex nut</b>			Units	
	M6, self-locking with flange (20 units)		3001660	_____	/each
	M6 with flange, stainless steel (10)		3054418	_____	/each
	M8 with hollow flange (50)		3018270	_____	/each
	M10 with flange and head teeth (10)		3054148	_____	/each
	M12 with locking paint and flange (10)		3042379	_____	/each

+<sup>0</sup> No surcharge

+<sup>3</sup> Surcharges for fascias in Color and RAL to choose, see page 136/indicate colour article number.





+<sup>4</sup> Surcharge for infill colour, see page 136

F = per field

**Note:** The minimum order quantities in brackets must be taken into account for screws, nuts etc.!

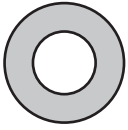
<b>ORDER</b>	Customer no.: _____	Order no./com.: _____	<b>*Please take information from the data label!</b>	
			Order no.: _____	Door no.: _____
	Customer name: _____		Product no.: _____	Type: _____
	Shipping address: _____		Year of manufacture: _____	
	Place/date: _____		Stamp and signature _____	

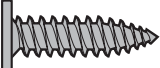
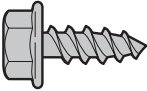
# 9. General Accessories

Article	Description	Production period	Art. no.	Qty.	€
	<b>Washer (20)</b>			Units	
	3.7		3039924	_____	/each
	A 10.5		3001784	_____	/each
	B 6.4		3014770	_____	/each
	9 × 20 × 2		3001849	_____	/each
	11		3001792	_____	/each
14 × 1.5		3040071	_____	/each	
	<b>Blank STS 12 (20)</b>		3063457	Units _____	/each
	<b>Grub screw (20)</b> With hexagon socket M12 × 16		3038890	Units _____	/each
	<b>Self-tapping screw with flat head and Torx</b> 3.9 × 15		3093920	Units _____	/each
	<b>Hexagon head tapping screw (50)</b>			Units	
	Self-tapping screw A 6,5 × 16, stainless steel		3091360	_____	/each
	A 6.5 × 16, Geomet		3040982	_____	/each
	Self-tapping screw A 6,5 × 19, stainless steel		3091361	_____	/each
	A 6.5 × 20, Geomet		3042487	_____	/each
	B 6.3 × 16, Geomet		3021742	_____	/each
	B 8 × 22, Geomet		3037010	_____	/each
	A 6.5 × 25, Geomet		3047034	_____	/each
A 6.5 × 75, Geomet		3062892	_____	/each	
	<b>Drilling screw (50)</b> 3.5 × 9.5 galvanized		3041298	Units _____	/each
	<b>Tallow-drop self-tapping screw (20)</b>			Units	
	B 2.9 × 9.5		3014673	_____	/each
	B 4.2 × 19		3017320	_____	/each
	B 4.2 × 49		3092448	_____	/each

+<sup>0</sup> No surcharge

+<sup>3</sup> Surcharges for fascias in Color and RAL to choose, see page 136 / indicate colour article number.





+<sup>4</sup> Surcharge for infill colour, see page 136

F = per field

**Note:** The minimum order quantities in brackets must be taken into account for screws, nuts etc.!

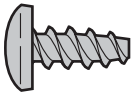
<b>ORDER</b>	Customer no.: _____	Order no./com.: _____	<b>*Please take information from the data label!</b>	
			Order no.:	Door no.:
	Customer name: _____		Product no.:	Type:
	Shipping address: _____		Year of manufacture:	
	Place/date: _____		Stamp and signature	

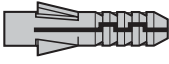
# 9. General Accessories

Article	Description	Production period	Art. no.	Qty.	€
	<b>Self-tapping screw (20)</b> 4.2 × 13, with tallow-drop Torx head, stainless steel		3065933	Units _____	/each
	<b>Hexagon wood screw (20)</b> 10 × 70		3047356	Units _____	/each
	<b>Drilling screw (50)</b> 5.5 × 25 K		3085579	Units _____	/each
	<b>Plastic plug 12 (20)</b>		3001946	Units _____	/each
	<b>Set: 4 frame plugs for side doors</b> 10 × 112		3088694	Units _____	/each

+<sup>0</sup> No surcharge

+<sup>3</sup> Surcharges for fascias in Color and RAL to choose, see page 136 / indicate colour article number.

+<sup>4</sup> Surcharge for infill colour, see page 136

F = per field

**Note:** The minimum order quantities in brackets must be taken into account for screws, nuts etc.!

<b>ORDER</b>	Customer no.: _____ Order no./com.: _____	<b>*Please take information from the data label!</b>	
	Customer name: _____	Order no.: _____	Door no.: _____
	Shipping address: _____	Product no.: _____	Type: _____
	Place/date: _____	Year of manufacture: _____	
		Stamp and signature _____	



# General Terms and Conditions of Sale and Delivery (Issue 01.03.2016)

## § 1 General

1. Our General Terms and Conditions of Sale and Delivery apply to all deliveries and services in accordance with the contract concluded between us and the Customer.
2. Our General Terms and Conditions of Sale and Delivery are exclusively applicable; Customers' conditions which conflict with or deviate from our conditions are not recognised unless we have agreed to them expressly in writing.
3. Our General Terms and Conditions of Sale and Delivery apply only to transactions with business entities as per § 14 of the German Civil Code [BGB].

## § 2 Entry into Contract

1. Our offers are without engagement and non-binding, unless otherwise agreed. Decisive for nature and scope is our order confirmation. We reserve the right to make technical changes as well as changes in form, colour and/or weight insofar as is reasonable.
2. The offer shall be regarded as accepted only when an order confirmation is issued or the goods are dispatched. The issue of a confirmation of receipt or the receipt of a telephone order do not constitute a binding acceptance. In the case of goods that have to be made to order, following our written confirmation the contract shall be regarded as having been entered into even if details of its execution which may affect price and delivery remain to be clarified. The right to make design and form changes during the delivery period is reserved, provided that the subject of delivery and its function and appearance are not fundamentally altered thereby. There will be no resulting change in price.
3. In respect of figures, drawings, calculations and similar documents, we reserve ownership and copyright. This likewise applies to such documents designated as "confidential". These documents may not be made available to third parties without our express prior approval.

## § 3 Prices and Terms of Payment

1. Unless otherwise specified in the order confirmation, our prices apply "ex works", excluding transport and assembly, which shall be invoiced separately. Costs for packaging, with the exception of small and spare parts, are included. The value added tax as required by law is not included in our prices; this tax will be shown separately on the invoice at the legal rate applicable on the date of invoicing.
2. Our invoices shall be due to be paid net (without deduction) within 30 days. The deduction of discounts requires a special agreement in writing.
3. Should the price of materials increase taxes or levies be increased after the contract has been concluded, we shall be entitled to adjust our prices accordingly if there are at least 4 months between entry into contract and intended delivery.
4. Should the Customer commission not only delivery but also assembly or similar services, these shall be invoiced by the hour unless a fixed rate has been agreed expressly. Our valid Terms and Conditions of Installation shall apply to all assembly services.
5. We are entitled, even in the case of conflicting Customer conditions, to set off payments against the Customer's previous debts. If costs and interest have already incurred, we are entitled to set off the payment against the costs, then to the interest and finally to the main service.
6. We are also entitled to make our remaining claims immediately payable and render the execution of all further services subject to an advance payment or provision of security, if we become aware of circumstances that call the solvency and the credit standing of the Customer into question, in particular in the event of default in payment. The right to claim further damages will remain unaffected.
7. During the delay, the Customer cannot invoke the right to possession. Any claim for return on our side during a delay on the Customer's side shall only be considered as withdrawal from the contract if we have specified this expressly in writing.
8. The Customer shall only have the right to offsetting if the Customer's counterclaims have been determined without further legal recourse, beyond dispute or if the counterclaims have been recognised by us. The Customer can only exert a right of retention if and when the counterclaim rests on the same contractual relationship.

## § 4 Place of Fulfilment, Transfer of Risk

1. Unless otherwise specified in the order confirmation, a delivery "ex works" (INCOTERMS 2010) has been agreed. The risk of accidental loss or deterioration of the goods purchased passes to the Customer upon hand-over of the goods to the shipping agent, the freight forwarder or the person or establishment otherwise appointed to execute the shipment. This shall likewise apply in case of partial delivery or if we have taken over other services (e.g. shipping or assembly).
2. Should the Customer be in default of acceptance, the risk of accidental loss or deterioration of the goods purchased shall pass to the Customer. Any storage costs incurred shall comply with § 5 No. 3.
3. If carriage paid delivery of the goods has been agreed, the means of transport must be unloaded immediately by the Customer. Waiting times will always be at the Customer's expense. Direct delivery to site shall always be regarded as on truck on an even, drivable road. Unloading including transportation to the place of use or storage is the responsibility of the Customer who in the event of delay must bear the cost and risk of unloading, stacking, storage or return transport. The recipient acting on behalf of the Customer at the place of unloading shall be regarded as authorised to accept the load with binding effect.

## § 5 Period of Delivery

1. The period of delivery specified by us shall only begin after clarification of all technical questions.
2. Information on delivery dates shall be considered the expected periods of delivery and are always subject to correct and timely delivery by suppliers and/or other manufacturers to us. The Customer may only set a time limit for the supply/performance if the expected delivery date has been exceeded by more than three weeks. This time limit must be reasonable and must amount to a minimum of three weeks. Claims for damages due to non-compliance with an expected delivery date are excluded. Delays in supply and performance as a result of force majeure or as a result of events which materially impede or prevent us from making delivery – including in particular subsequent material sourcing difficulties for which we are not responsible, interruption of operations, strikes, lockouts, official directives, etc., even if these affect our suppliers or sub-suppliers – will be notified to the Customer immediately. Events of this type entitle us to withdraw from the contract either in whole or in part if the order is not yet completed. In the event of withdrawal, any compensating measures already performed by the Customer shall be reimbursed immediately.
3. Should the Customer be in delay of acceptance, we are entitled to store the goods at the Customer's risk and expense. For the corresponding storage costs, we can optionally demand reimbursement of the actually incurred costs or of a fixed rate of 5% of the invoice sum for each commenced month. This also applies to storage by us. The Customer has the right to prove less damage in the event of a claim to flat-rate damage reimbursement.
4. Should, after the time limit set by us has expired, the Customer refuse to accept the goods or declare to no longer want to accept the goods without entitlement to do so, we can also demand damage compensation due to non-fulfilment.
5. Partial deliveries are permissible to a reasonable extent.

## § 6 Reservation of Title

1. We reserve ownership of the goods until complete payment of all claims from the ongoing business relationship with the Customer. Should the value of the reserved goods exceed the claims to be secured from the ongoing business relationship with the Customer by more than 20%, we are obligated to release the reserved goods on Customer request. The selection of the securities to be released is at our discretion.
2. While retention of title is in effect, the Customer is obligated to treat the goods purchased with care and sufficiently insure them against fire, water and theft at their value when new and at the Customer's expense. Any claims asserted for damages by the Customer against the insurer or other third parties due to deterioration of the reserved goods are right now signed over to us at the amount of the invoice sum. Should maintenance and inspection work be required, the Customer shall perform said work regularly at the Customer's own expense. The Customer must inform us immediately and in writing of all access of third parties to the goods, in particular of all foreclosure and any damage to or destruction of the goods. The Customer must inform us of a change in possession of the goods as well as a change in the Customer's address immediately. The Customer must reimburse us of all damage and costs caused by a violation of this obligation and resulting necessary intervention measures to prevent access of third parties to the goods. In the event of access by third parties, the Customer must also provide us with the necessary help to exercise our rights.
3. The Customer is not permitted to pledge reserved goods nor assign them as security.
4. Processing or transformation of goods supplied subject to the reservation of title is always undertaken by the Customer on our behalf. Should the reserved goods be combined or processed with other items, the reservation of title shall continue for the processed or combined goods. If the reserved goods are processed or combined inextricably with items which are not our property, we shall acquire ownership of the new object in the ratio of the invoice value of the reserved goods to the invoice value of the other goods used at the time of processing or combination. The resulting co-ownership rights shall be deemed to be reserved goods in accordance with these terms and conditions. If our goods are joined or combined inextricably with other movable items into a single object and the other object is to be considered the main object, the Customer shall concede proportionate joint ownership to us should the main object belong to the Customer. In the aforementioned cases, the Customer here and now assigns all ownership rights to the processed, joined, or combined goods to us. Instead of a transfer, the Customer shall hold the processed, joined, or combined object in safe custody on our behalf. For the object resulting from processing, use, or combination, the same applies in all other respects as for reserved goods.
5. The Customer is entitled to resell goods supplied subject to reservation of title by way of due and proper business transactions. The Customer here and now assigns all claims with all rights arising from the resale of the reserved goods to us in full. We accept this assignment. Should the Customer sell the reserved goods – after processing/combination – together with goods not belonging to the Customer, the Customer here and now assigns to us the claims resulting from resale at the value at new of the reserved goods along with all ancillary rights. We accept this assignment right now. The Customer is entitled to collect this claim even after assignment. However, we reserve the right to collect the claim ourselves as soon as the Customer fails to properly meet payment obligations and enters into default, or reasonable doubt about the Customer's solvency and credit standing exists. On our request, the amount of the assigned claim, the person of the debtor and all other information required for collection must be provided, the corresponding documents be handed over and the debtor be notified of the assignment.
6. The right to further processing and resale ends with withdrawal from the contract.
7. During the Customer's standard business hours, we are at all times entitled to enter the offices and operating premises to check the reserved goods and to take possession of the reserved goods insofar as the Customer is unable to invoke rights to possession.

## § 7 Defect Claims

1. The Customer shall be entitled to claims for defect only if the Customer's duties to inspect and report pursuant to § 377 of the German Commercial Code [HGB] have been duly complied with. In the event that complaints are not reported in due time and/or in due form, the goods shall be regarded as accepted.
2. For the delivery of objects, we are free to decide to affect supplementary performance either by repair or replacement. If supplementary performance fails, the Customer can at his choice demand a reduction, withdrawal or compensation. In the event of only minor defects the Customer has no right to withdrawal.
3. As a matter of principle, the nature of the goods purchased shall be defined solely by the manufacturer's product description/order confirmation. Public statements, recommendations or advertisements by the manufacturer do not constitute contractual statements as to the nature of the goods.
4. The period of limitation for defect claims is based on § 438, Para. 1, No. 2 of the German Civil Code [BGB] as long as no deviating time limits have been expressly agreed.
5. The Customer is not entitled to assign claims for material defects.

## § 8 Liability

1. We accept liability within legal provisions, provided the Customer asserts claims for damages that are based on intent or gross negligence. In the event of minor negligence, our liability is limited to predictable, typically occurring damage. We are not liable in the event of minor negligence of non-essential contractual obligations whose violation does not threaten the performance of the contract. This also applies to breach of duty by our legal representatives or vicarious agents.
2. Liability for negligent injury to life or limb or the impairment of a person's health remains unaffected from the above limitations of liability; this also applies to Customer claims according to the German Product Liability Act [Produkthaftungsgesetz].

## § 9 Concluding Provisions

1. The law of the Federal Republic of Germany shall apply. The UN Convention on the International Sale of Goods shall not be applicable.
2. To take legal effect, subsidiary agreements and amendments must be confirmed in writing. This likewise applies to any modification of the clause stipulating the written form.
3. Unless otherwise specified in the order confirmation, our headquarters are the place of fulfilment. The exclusive place of jurisdiction for all disputes arising from this contract shall be Bielefeld, Germany.
4. Insofar as individual terms of the contract including these General Terms and Conditions should be or become ineffective either in whole or in part, this shall not affect the validity of the remaining provisions.

# Hörmann: Quality without Compromise



Hörmann KG Amshausen, Germany



Hörmann KG Antriebstechnik, Germany



Hörmann KG Brandis, Germany



Hörmann KG Brockhagen, Germany



Hörmann KG Dissen, Germany



Hörmann KG Eckelhausen, Germany



Hörmann KG Freisen, Germany



Hörmann KG Ichttershausen, Germany



Hörmann KG Werne, Germany



Hörmann Alkmaar B.V., Netherlands



Hörmann Legnica Sp. z o.o., Poland



Hörmann Beijing, China



Hörmann Tianjin, China



Hörmann LLC, Montgomery IL, USA



Hörmann Flexon LLC, Burgettstown PA, USA



Shakti Hörmann Ltd., India

Hörmann is the only manufacturer worldwide that offers you a complete range of all major building products from one source. We manufacture in highly-specialised factories using the latest production technologies. The close-meshed network of sales and service companies throughout Europe, and activities in the USA and Asia, make Hörmann your strong partner for first-class building products, offering "Quality without Compromise".

**GARAGE DOORS**

**OPERATORS**

**INDUSTRIAL DOORS**

**LOADING EQUIPMENT**

**HINGED DOORS**

**DOOR FRAMES**

**HÖRMANN**