

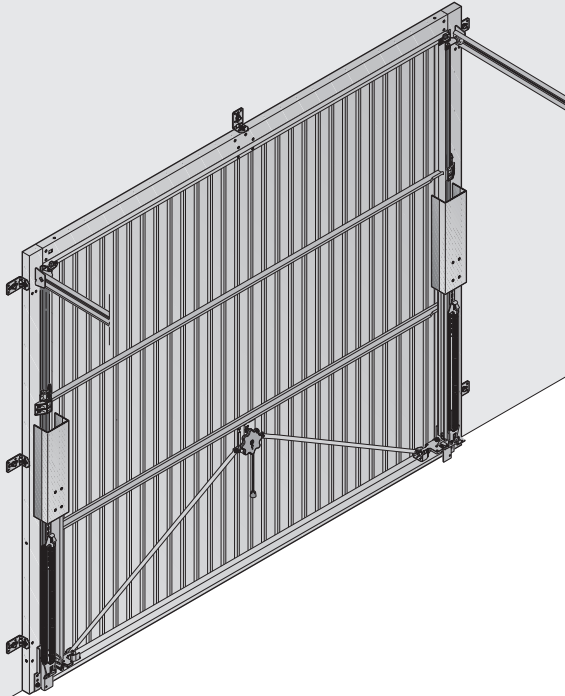

Installation, Operating and Maintenance Instructions

Retractable Door



CONTENTS	PAGE		
1 SAFETY REQUIREMENTS	3	4.3	Checking the tension of the springs 9
1.1 Symbols and key words used	3	4.4	Replacing the door's tension springs 9
1.2 Designated use	3	4.5	Checking the tracks and track rollers 10
1.3 General safety advice	4	4.6	Checking the lock and rotary latches 10
		4.6.1	Adjusting the latch assembly 10
		4.7	Accessories 10
2 FITTING AND INITIAL OPERATION	4	5 SURFACE PROTECTION	10
2.1 Safety advice	4	5.1	Door with steel infill 10
2.2 Fitting	5	5.2	Door with timber or GRP infill 11
2.2.1 Doors with centre profile/horizontal rib	6	6 CLEANING AND CARE	11
2.2.2 Fitting the handle	6	6.1	Steel door surfaces 11
2.2.3 Fitting to ceiling	7	6.2	Synthetic panes 11
2.2.4 Checking the door action and door stop	7	6.3	Type plate 11
2.3 Initial operation	7	7 TROUBLESHOOTING	11
2.3.1 Checking the tension of the springs	7	8 DISMANTLING	11
3 OPERATION	8		
3.1 Safety advice	8		
3.2 Opening and closing	8		
3.3 Opening the door with the handle	8		
3.4 Locking and unlocking the door	8		
4 CHECKS AND MAINTENANCE	9		
4.1 Safety advice	9	Illustrations steel frame	12/36
4.2 Checking the condition of the door	9	Illustrations timber frame	37/57

Make sure that these instructions are retained by the operator of the garage door!

Keep these instructions together with the warranty booklet and declaration of conformity in a safe place for later reference.

Enter the serial no (see type plate).

Serial no.:

1 SAFETY REQUIREMENTS

Read and follow these instructions carefully!

They provide you with important information on the safe fitting, operation as well as proper care and maintenance of the garage door.

Installation, putting into operation and maintenance must be carried out by a qualified specialist (competent person as defined in the European Standard EN 12635) in accordance with these instructions. In doing so, the requirements of the European Standards EN 12604 and EN 12635 must be complied with. Damage incurred as a result of failing to comply with these instructions and safety advice shall exempt the manufacturer from all liability.

1.1 Symbols and key words used

Special safety advice and/or instructions are provided at the respectively relevant sections. They are denoted by the following symbols and key words.



RISK OF INJURY!

Wear protective goggles and gloves.



CAUTION!

Warns about the risk of physical injury.



NOTE!

Warns about the risk of damage to property or malfunctions.

1.2 Designated use

- The garage door is designed and intended for domestic use only. If you intend using the garage door in the commercial sector, check beforehand as to whether the applicable national and international regulations permit such use.
- The garage door is suitable for outdoor applications and opens outwards with an up-and-over action.
- The garage door can be operated manually or be equipped for power operation.

1.3 General safety advice



RISK OF INJURY!

When fitting, always wear protective goggles and gloves.



CAUTION!

- Always allow sufficient clearance for the swing-out action of the door! When operating the door, always make sure that there are no objects or persons, especially children, within the door's range of movement!
- Do not alter or remove any structural components! You otherwise risk putting important safety components out of operation. Only ever use genuine spare parts specifically designed for the garage door.
- Do not attach any additional structural components of another make! The tension springs are matched to the door leaf weight. Additional structural components can overload the springs.
- Functional parts, in particular safety-related components, should only be replaced by a specialist.
- Operating the door under wind pressure can be dangerous.



NOTE!

- Attach all the supplied fixings and fastenings in accordance with the fitting instructions! Failure to do so could otherwise impair the functional safety of the door.
- During fitting, protect the door frame with bearing block and door leaf against drillin dust.



RISK OF CORROSION!

- Protect the door from caustic, aggressive substances, e.g. nitrous reactions from stones or mortar, acids, alkali solutions, de-icing salt, aggressive paints or sealants.
- Ensure adequate drainage and ventilation (drying) in the bottom region of the side frames.

2 FITTING AND INITIAL OPERATION

2.1 Safety advice



RISK OF INJURY!

Wear protective goggles and gloves.



CAUTION!

- Safeguard the door against falling over!
- Support the track safely and securely!

- Safeguard the door leaf against crashing to the floor!
- Only ever fit the timber infill door to garages that are dry!

**NOTE!**

Make sure that the connection to the building structure is sound. Check that the fixing materials supplied are suitable for the given structural conditions. Do not fasten the door system to supporting structural members unless you have obtained the prior approval of the structural engineer.



Note the written information to be read in conjunction with the figure (e.g. point 2.2.1). It provides you with important pointers on how to safely fit and operate the garage door.

2.2 Fitting

Fitting to steel frame

The garage door can be installed from inside the garage, either behind the opening or in the opening.

Fitting to timber frame

**NOTE!**

- Before fitting the door, check carefully the opening size and squareness of the timber frame (the door is manufactured slightly smaller to give the correct clearance between door leaf and timber frame).
- The timber frame should be of the "Goalpost" type, with a minimum nominal size of 70 mm x 70 mm (2 2/3" x 2 2/3") once erected it should provide an inside frame dimension as detailed.

Door size	Inside frame dimension in Imperial	Inside frame dimension in Metric
6'6" x 6'6"	6'6" x 6'6"	1981 x 1981
6'6" x 7'0"	6'6" x 7'0"	1981 x 2134
6'10" x 6'4"	6'10" x 6'4"	2083 x 1931
7'0" x 6'4"	7'0" x 6'4"	2134 x 1931
7'0" x 6'6"	7'0" x 6'6"	2134 x 1981
7'0" x 7'0"	7'0" x 7'0"	2134 x 2134
7'3" x 6'4"	7'3" x 6'4"	2210 x 1931
7'5" x 6'6"	7'5" x 6'6"	2261 x 1981
7'5" x 7'0"	7'5" x 7'0"	2261 x 2134

7'6" x 6'4"	7'6" x 6'4"	2286 x 1931
7'6" x 6'6"	7'6" x 6'6"	2286 x 1981
7'6" x 7'0"	7'6" x 7'0"	2286 x 2134
7'8" x 6'4"	7'8" x 6'4"	2337 x 1931
8'0" x 6'4"	8'0" x 6'4"	2438 x 1931
8'0" x 6'6"	8'0" x 6'6"	2438 x 1981
8'0" x 7'0"	8'0" x 7'0"	2438 x 2134
9'0" x 6'6"	9'0" x 6'6"	2743 x 1981
9'0" x 7'0"	9'0" x 7'0"	2743 x 2134

All the dimensions stated in the illustrated section are in mm.

Door open for on-site infill



CAUTION!

- Without the weight of the infill, the door swings upwards extremely quickly.
- Maximum infill weight 7kg/m² for doors with integral wicket door.

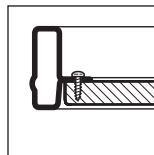

Infill in the frame

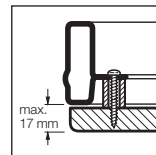

Infill overlapping the frame

Maximum permissible infill weight for an on-site infill:

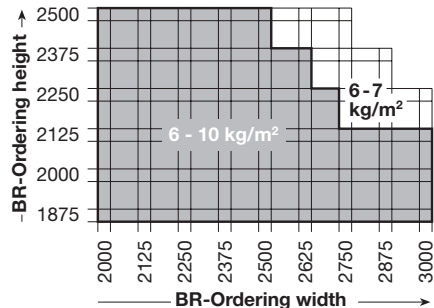

2.2.1 Doors with centre profile/horizontal rib

The spacer bush with square hole is only used on doors with a centre profile or horizontal rib.

2.2.2 Fitting the handle



NOTE!

- Select the pin setting (a, b or c) with the largest possible guide for the internal handle.
- If measurement A is below 36 mm, shorten the pin of part (C).

2.2.3 Fitting to ceiling



CAUTION!

When fitting to the ceiling, make sure that you have sufficient headroom. If necessary, shorten the universal anchor flush with the bottom edge of the track.

2.2.4 Checking the door action and door stop



NOTE!

Check the door action and door stop. To ensure a smooth-running door, the diagonal dimensions a and b must be equal and in the end-of-travel position the rubber buffers on both sides must contact the rear spacer.

To install the door simply and safely, carefully carry out the work stages according to figures 1 to 9.3 (10 to 18.3)!

2.3 Initial operation

2.3.1 Checking the tension of the springs (fig. 6.4/16.5)

Half open the door. The door should hold this position.



CAUTION!

- The door's tension springs must be adjusted by a specialist only with the door open and secured, as shown in figure 6.4/16.5 (1-4)!
- After setting the tension of the springs, secure the spring holders with the spring plugs.

If the door drops down significantly, increase the tension of the springs.

If the door pulls upwards significantly, decrease the tension of the springs.

Make a test run and check the door in accordance with section 4 "Checks and Maintenance".

When the garage door is properly fitted and checked, it runs smoothly, functions safely and is easy to operate.

3 OPERATION

3.1 Safety advice



CAUTION!

Always allow sufficient clearance for the swing-out action of the door! When operating the door, always make sure that there are no objects or persons, especially children, within the door's range of movement!

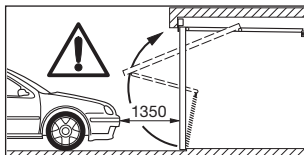

Maintain a safety distance of 1350 mm in front of the door.

3.2 Opening and closing



CAUTION!

- Manual opening only using the external or internal handle, on no account using the lifting arm or the pull cord with knob!
- Manual closing only using the external or internal handle, or the pull cord with knob to start. On no account using the lifting arm!

- When opening the door, always push it back to the end-of-travel position and wait for it to come to a complete standstill!
- When closing the door, always make sure that the rotary latches has engaged.

3.3 Opening the door with the handle

When the garage door is closed with the handle, it is not locked. To lock the door, use the key or looking snib.

Opening from the outside

Rotate the handle a quarter turn clockwise.

Opening from the inside

Rotate the handle a quarter turn anti-clockwise.

3.4 Locking and unlocking the door

From the outside using the key and from the inside using the looking snib.

Unlocking from the outside

Rotate the key a full turn clockwise and then withdraw it.

Locking from the outside

Rotate the key a full turn anti-clockwise and then withdraw it.

Locking from the outside - self-latching
 Rotate the key a half turn clockwise, slightly open the door, turn the key back to the starting position and then withdraw it. Once the door has closed, the lock is engaged again.

Unlocking from the inside
 Push the looking snib to the left.
 After unlocking the door in this way, you can then open it without a key.
 Locking from the inside
 Push the looking snib to the right.

- For doors fitted with an operator, follow the manufacturer's operating instructions.
- For steel doors with ventilation slots the latching is horizontal, with non-resilient rods and the looking snib is concealed for security reasons.

4 CHECKS AND MAINTENANCE

4.1 Safety advice



CAUTION!

- Have the door inspected and maintained at least once a year by a specialist in accordance with these instructions!

- Always allow sufficient clearance for the swing-out action of the door! When operating the door, always make sure that there are no objects or persons, especially children, within the door's range of movement!

4.2 Checking the condition of the door

- Make a visual check of the general condition of the door, all the structural components and safety devices to ensure that these are still complete, effective and in good working order.
- Check that all the fixing points are firmly seated, and if necessary, tighten the screws!
- Lubricate all the pivots with a commercially available penetrating/lubricating oil, do not apply grease, see fig. 8.1/17.1.

4.3 Checking the tension of the springs

See section 2 "FITTING AND INITIAL OPERATION".

4.4 Replacing the door's tension springs

After approx. 25,000 door cycles have the tension springs replaced by a specialist.

This is necessary as follows:

- | | | |
|-------|-----------------------------|----------------|
| up to | 5 door cycles per day: | every 15 years |
| up to | 6 - 10 door cycles per day: | every 8 years |

up to 11 -20 door cycles per day: every 4 years
 up to 21 -40 door cycles per day: every 2 years
 more than 40 door cycles per day: once a year

4.5 Checking the tracks and track rollers

- Clean the tracks but do not apply grease.
- Check the track rollers for wear. If these appear to be worn, have them replaced by a specialist.

4.6 Checking the lock and rotary latches



NOTE!

- Only use specialised maintenance products for the profile cylinder. Do not use oil or graphite!
- Lubricate the rotary latches with a commercially available penetrating/lubricating oil, do not apply grease!

Check the rotary latches in accordance with fig. 1.2/14.1 and if necessary, adjust.

4.6.1 Adjusting the latch assembly (fig. 9.1/18.1)

The latch assembly is already set for the standard case. If there are inaccuracies in the building structure, loosen the nuts, push the latch assembly in the direction of the arrow and then retighten the nuts.

4.7 Accessories

- In order to ensure the high performance standard of quality, safety, reliability and durability, only ever use genuine spare parts specifically designed for the garage door.
- Only use an operator approved for the garage door in accordance with the European Standard EN 13241-1. In doing so, observe the separate fitting and operating instructions provided by the manufacturer of the operator. Immobilize both rotary latches.
- Should you wish to retain the function of the rotary latches even when using an electric operator, use the de-latching set for up-and-over garage doors.

5 SURFACE PROTECTION

5.1 Door with steel infill

The door leaf is made of galvanized steel and has been finished with a polyester powder-coating. Scratches or minor damage do not constitute grounds for complaint. If you chose to paint the door then:

1. Slightly sand down the door surface with fine emery paper (at least 180-size grain)
2. Clean the door surface with water and dry.

3. Treat the door surface with a solvent-based 2-component epoxy adhesive primer and a commercially available resin paint for outdoor applications. Both coats must be compatible. In the process, follow the manufacturer's directions for use.

Renew the final coat as and when necessary, depending on the local climatic conditions.

5.2 Door with timber or GRP infill

See separate instruction label on inside face of door panel.

6 CLEANING AND CARE

6.1 Steel door surfaces

Clean the door surfaces with clear water and a soft sponge or with commercially available paint cleaners.

6.2 Synthetic panes



NOTE!

Do not use any abrasive cleaning agents, sharp tools or glass cleaners containing alcohol! They can cause stress cracking and damage the panes.

Clean synthetic panes with clear water and a soft cloth or sponge. In the case of heavier soiling, use a mild,

acrylic-compatible plastics cleaner. Please also follow the manufacturer's directions for use.

6.3 Type plate

Clean the type plate - it should be clearly legible at all times.

7 TROUBLESHOOTING

In the event of a sluggish door action or other malfunctions, check all the functional components. For further instructions, refer to section 4 "CHECKS AND MAINTENANCE".

If any points are unclear, consult a specialist.

8 DISMANTLING

Have the door dismantled and properly disposed of by a specialist.

Protected by copyright! No part of these instructions may be reproduced without our permission. Subject to changes.

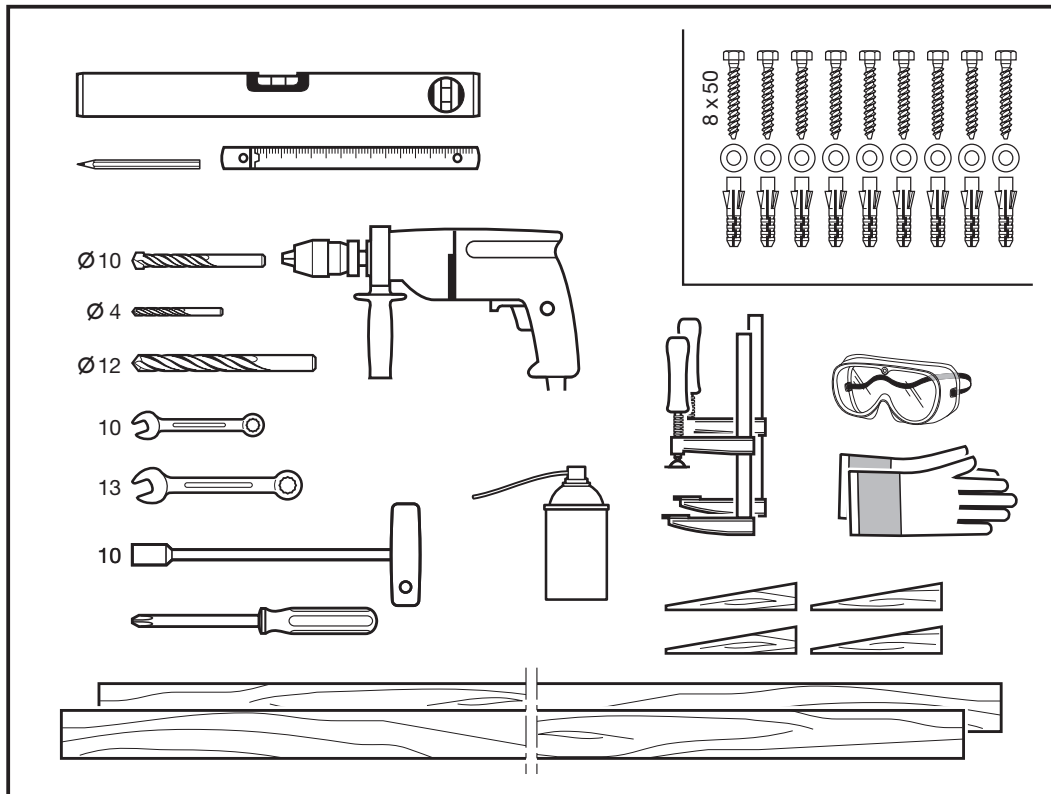

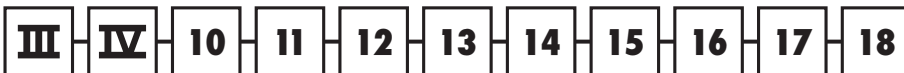
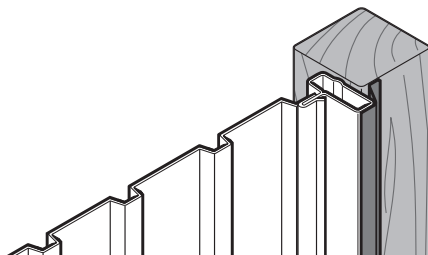
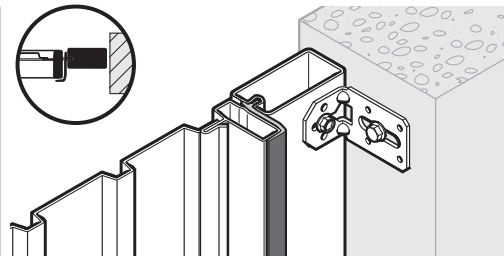
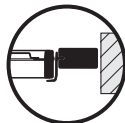
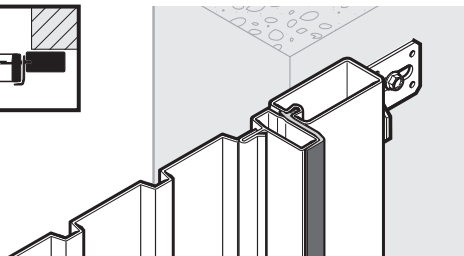
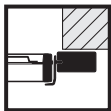

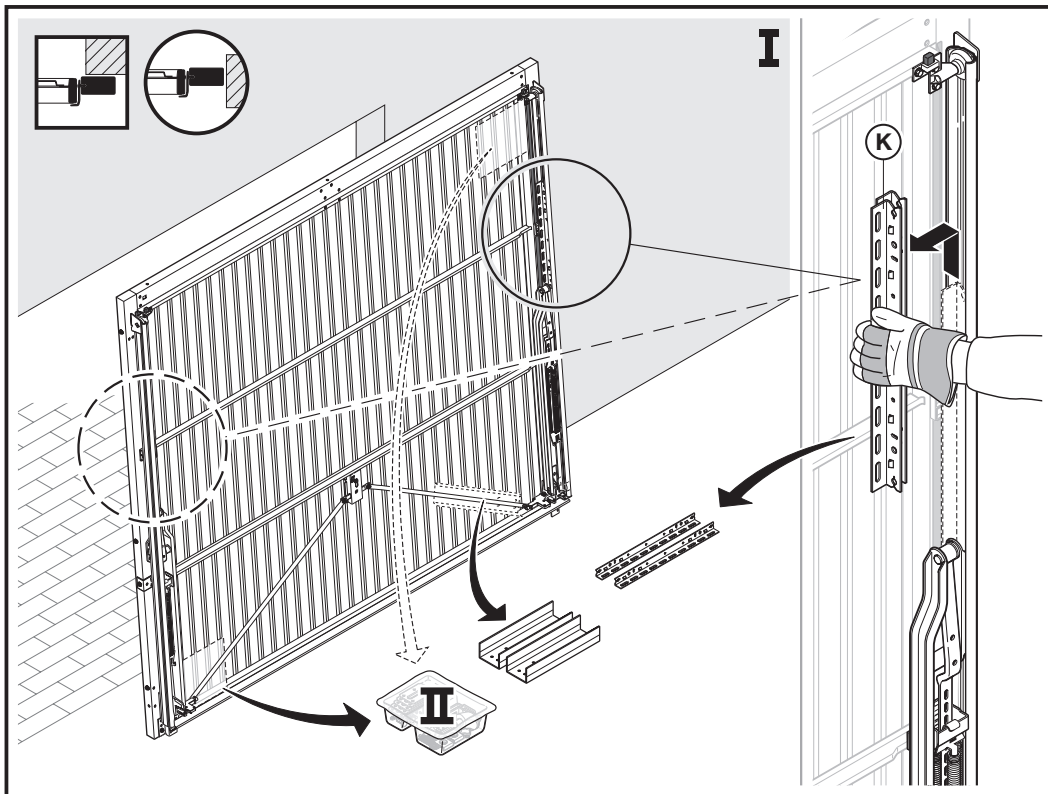

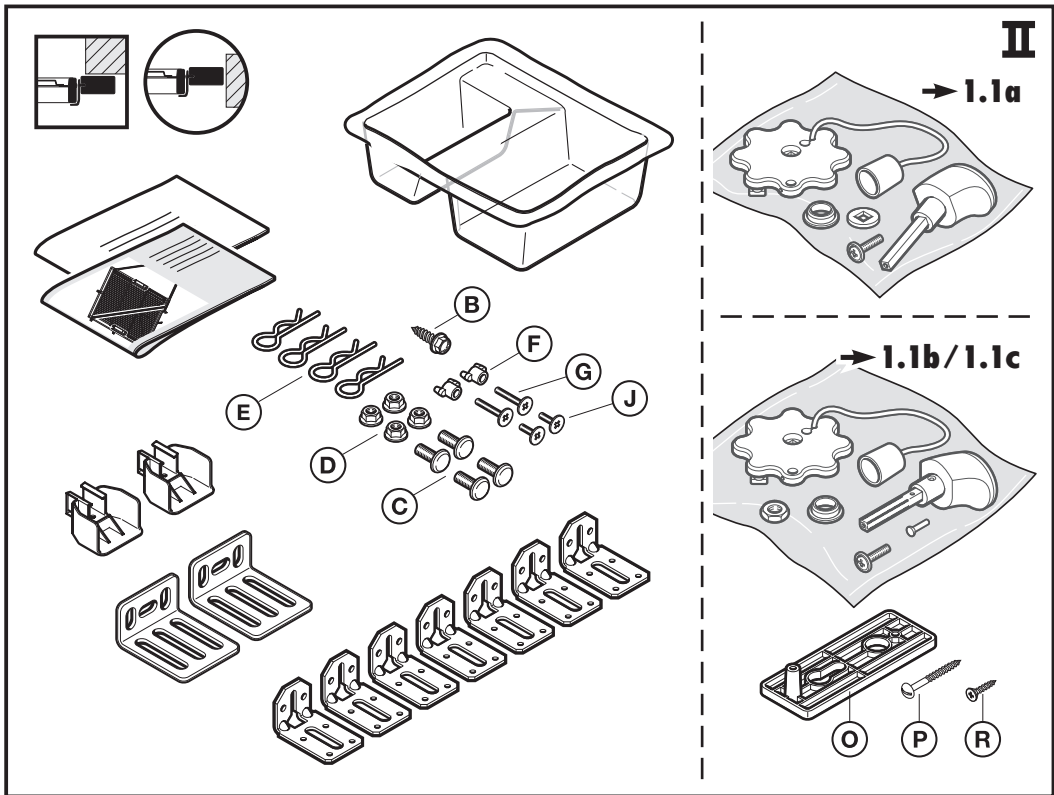

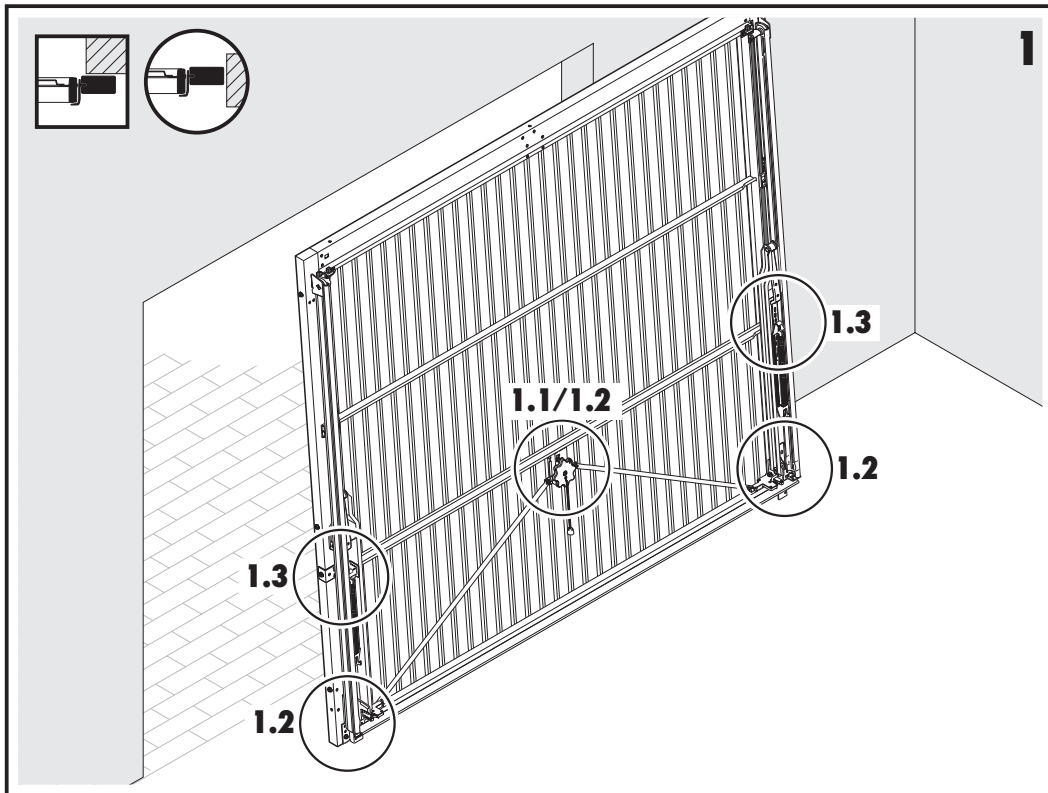

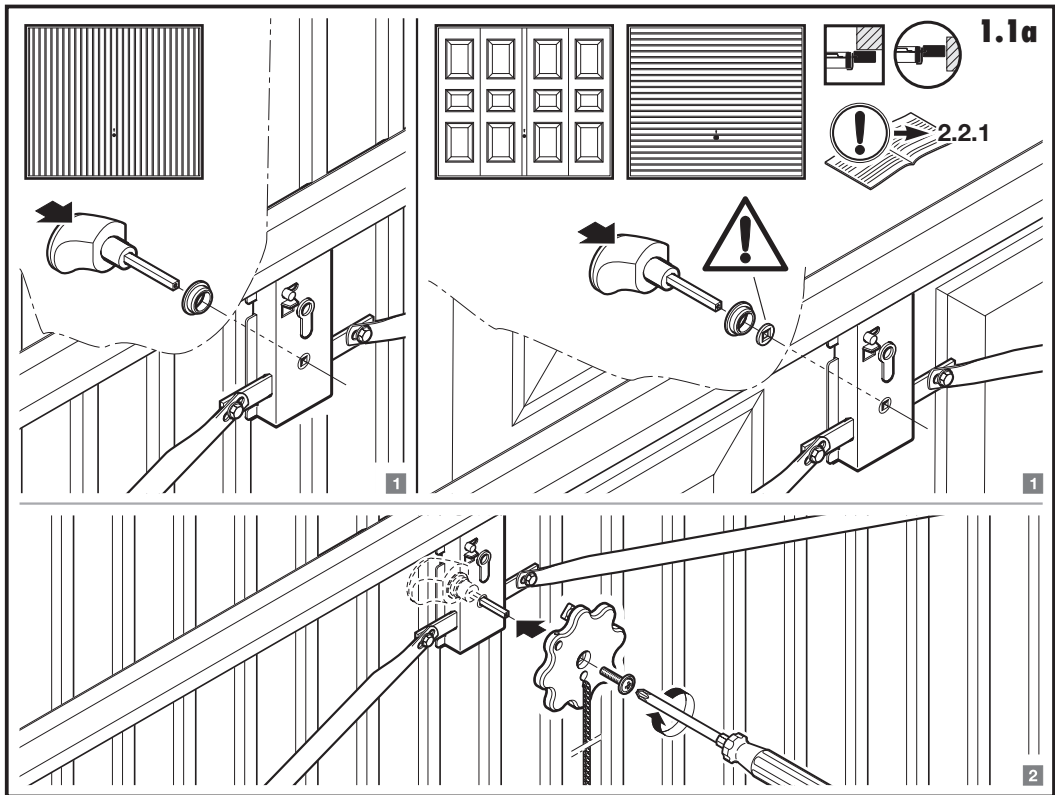

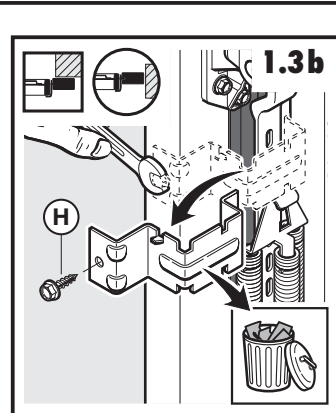
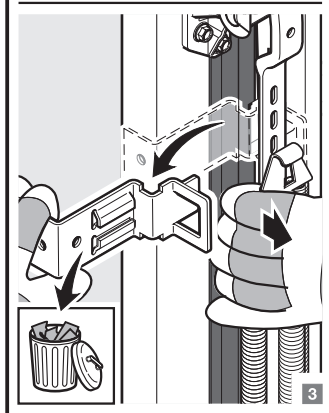
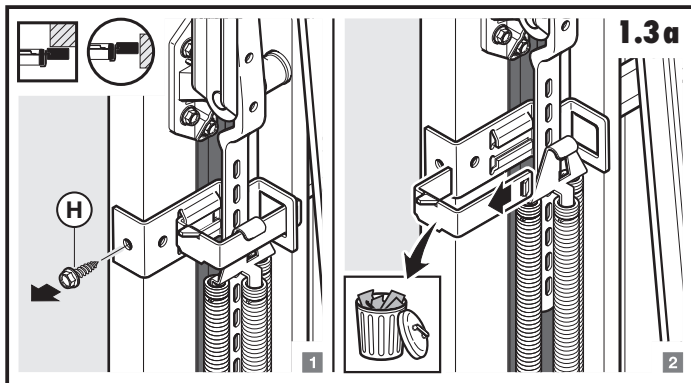
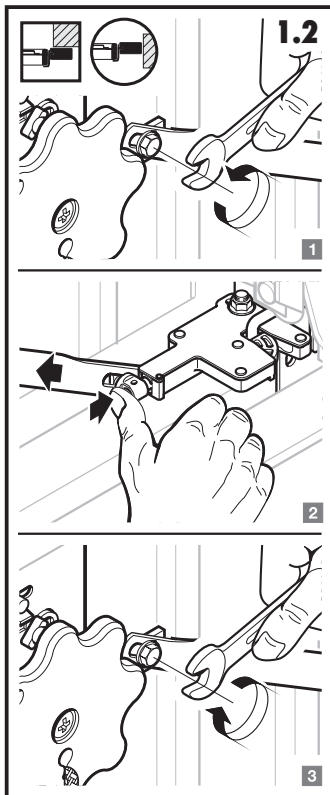

2

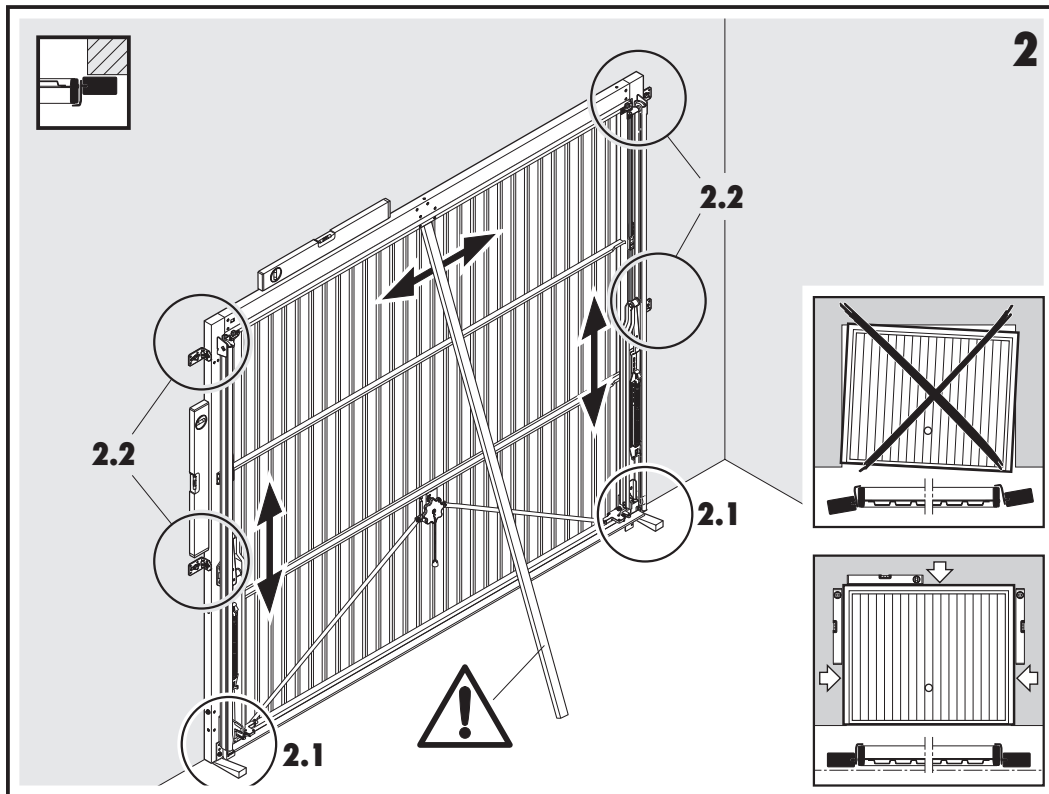

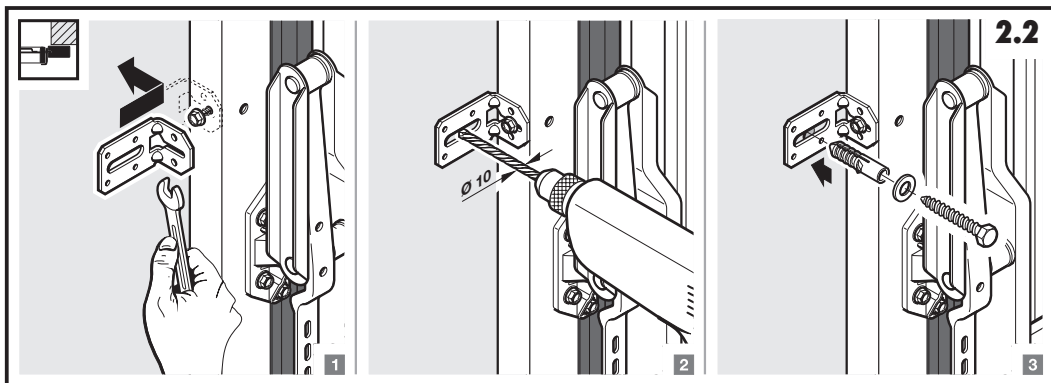
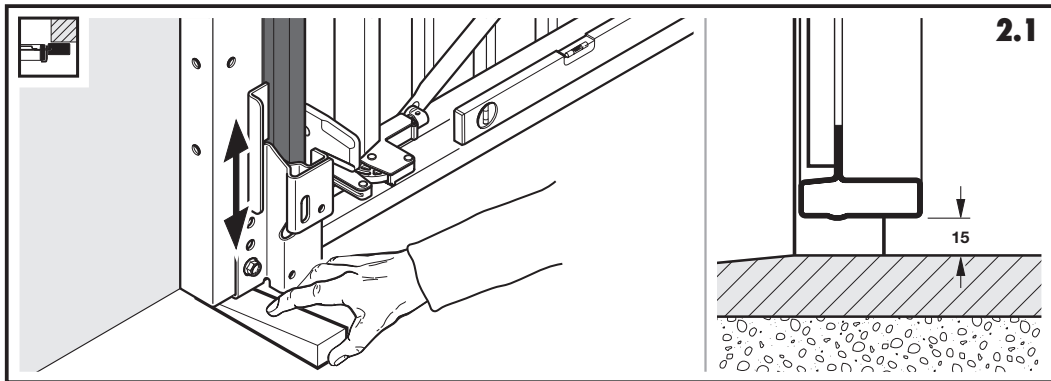

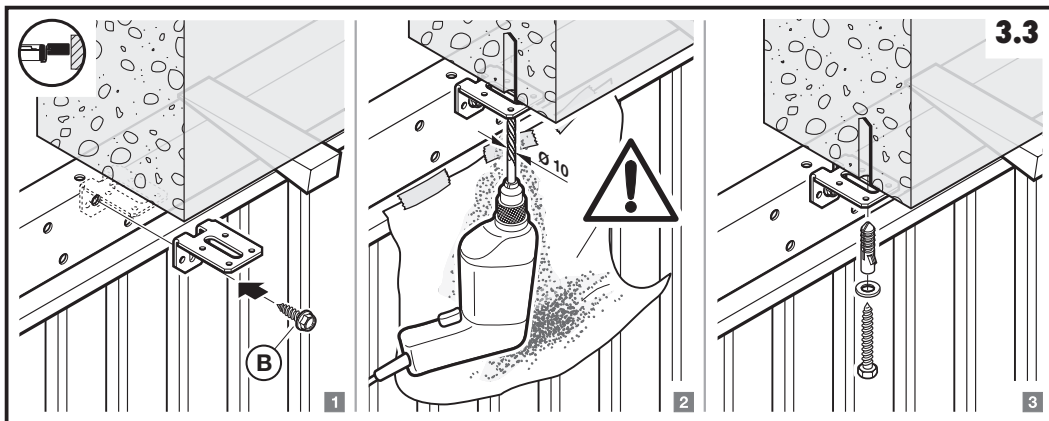
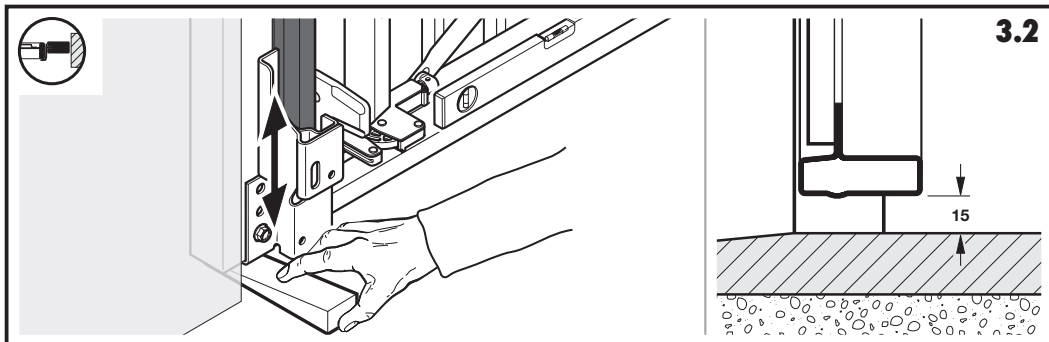

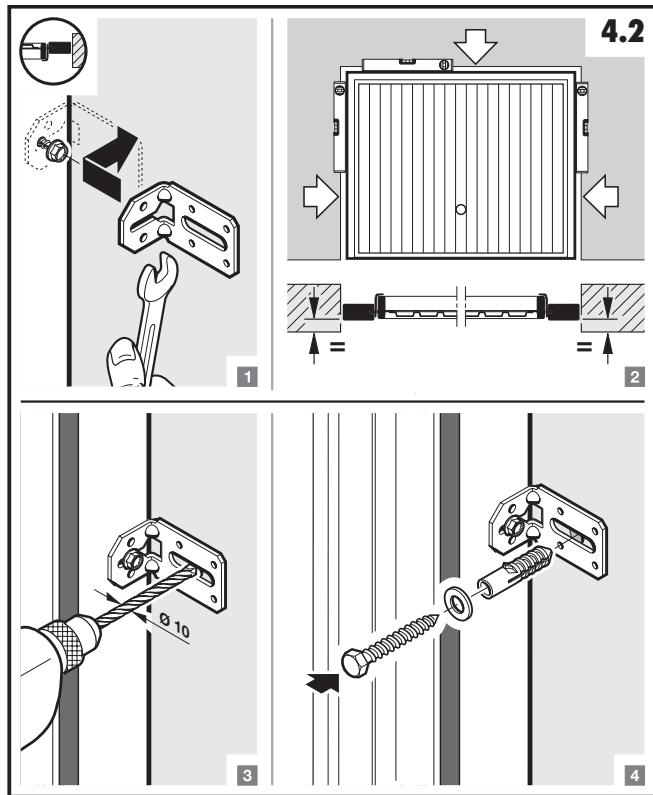
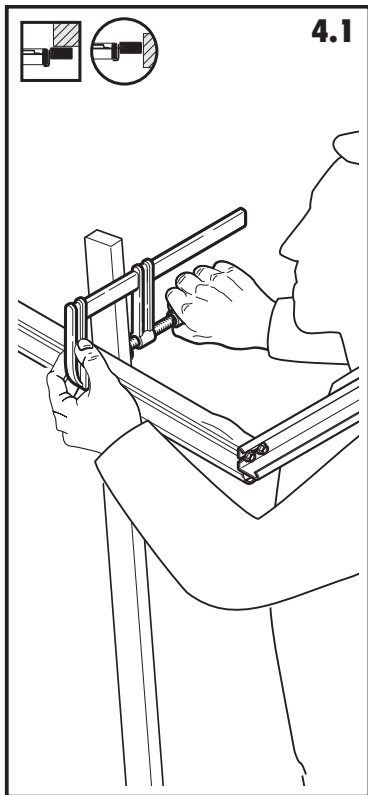

5

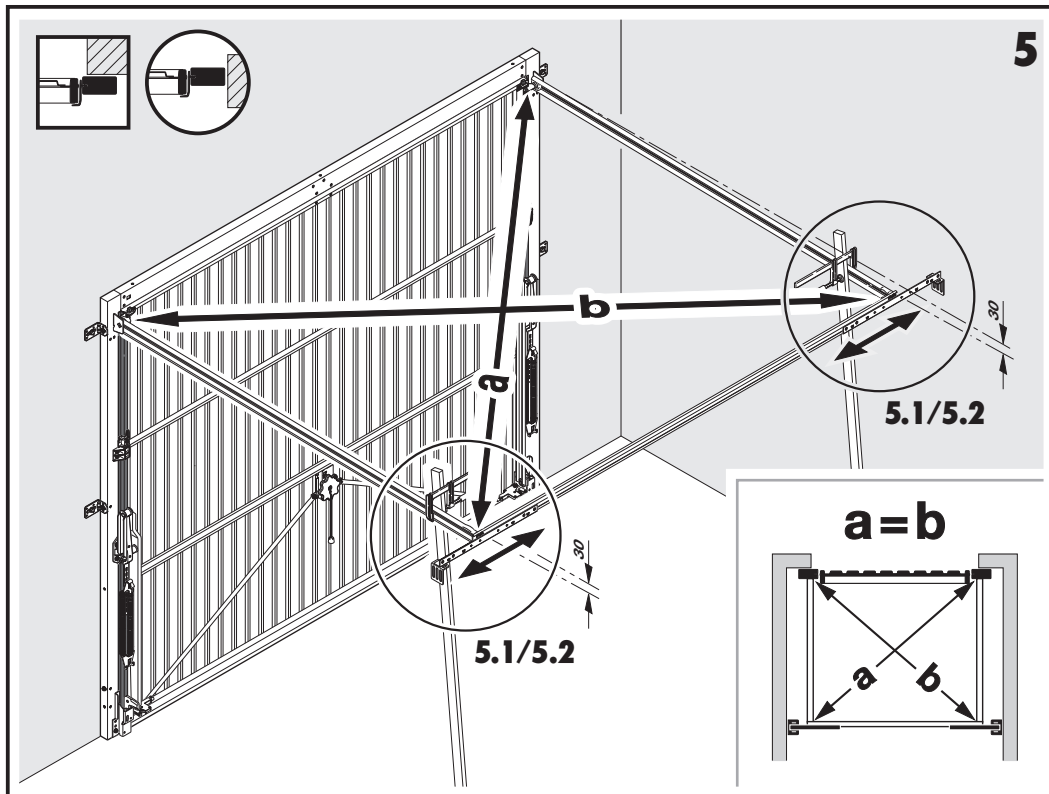

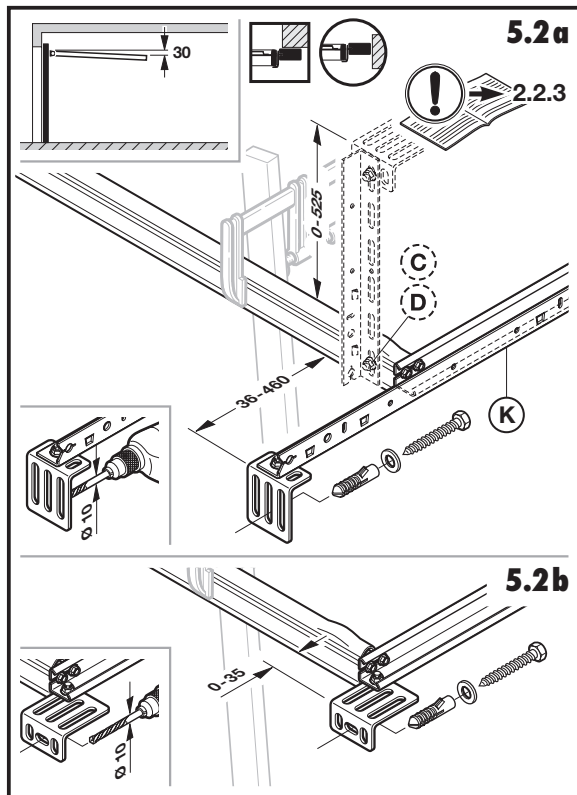
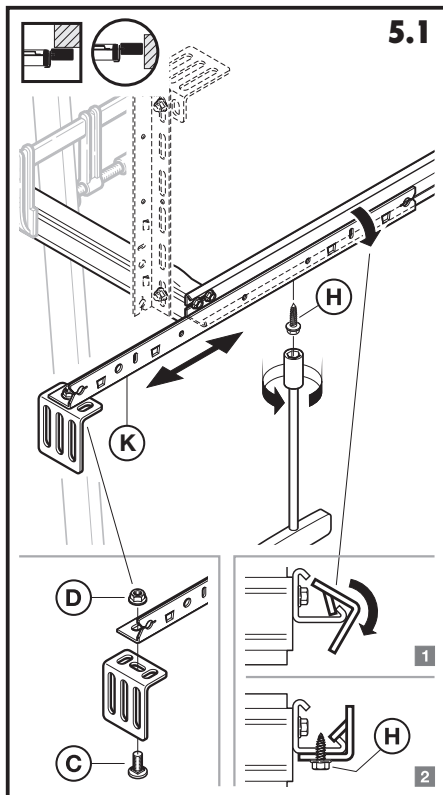

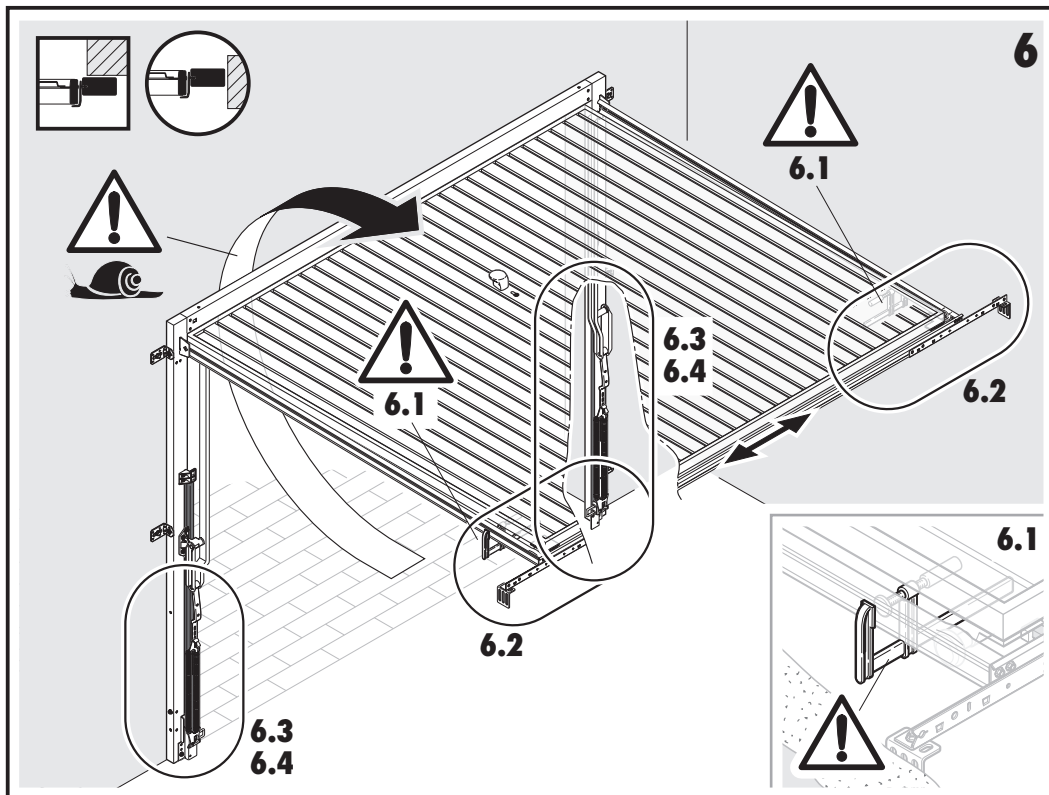

6.2

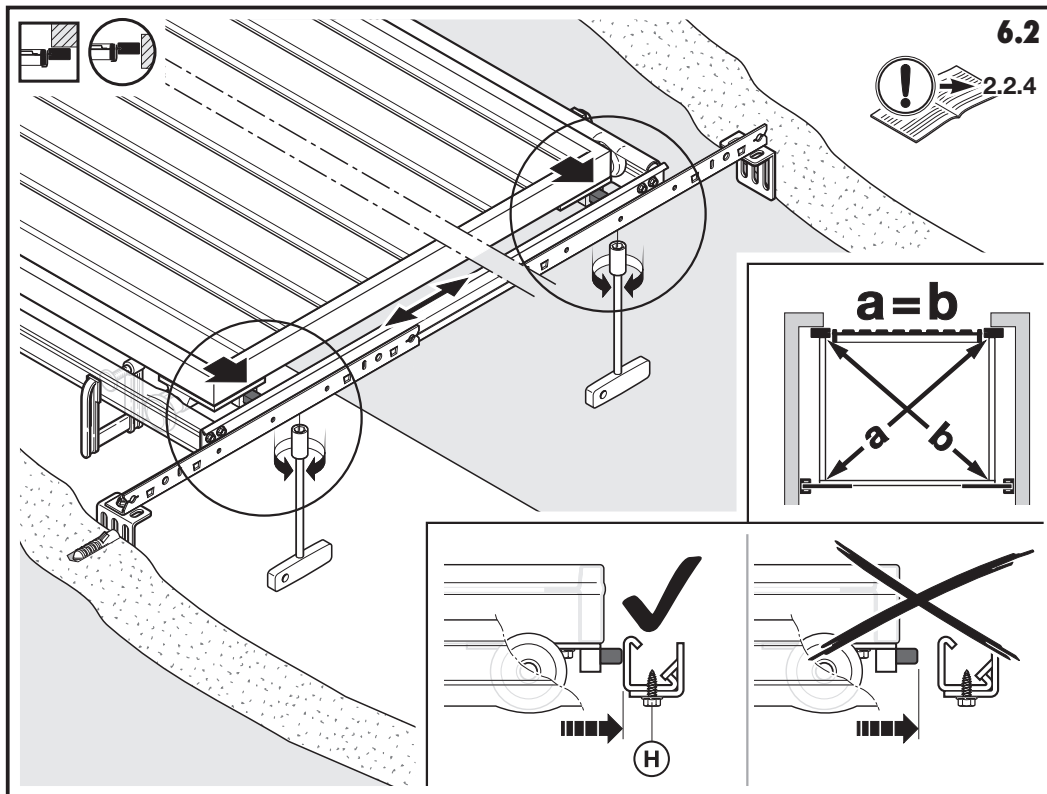

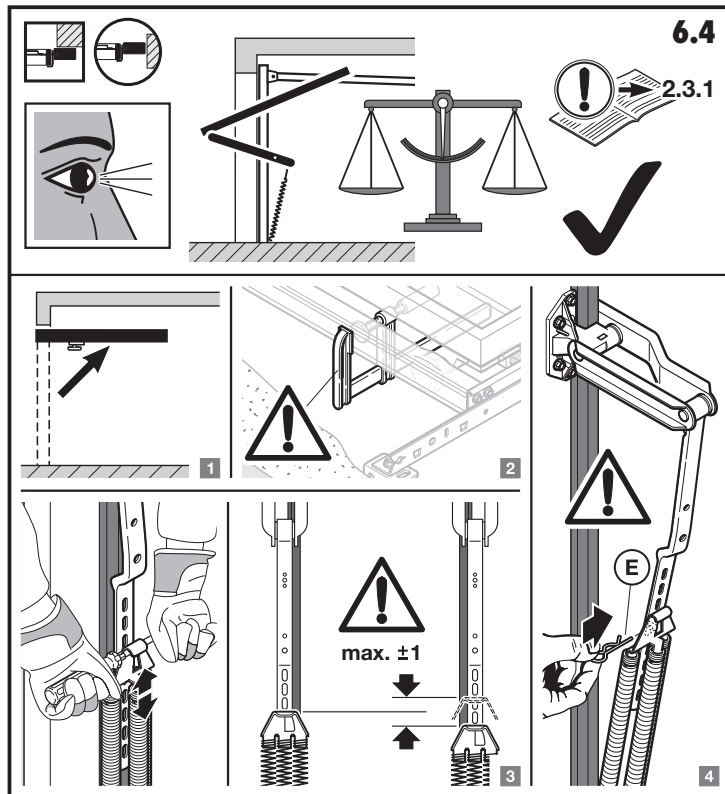
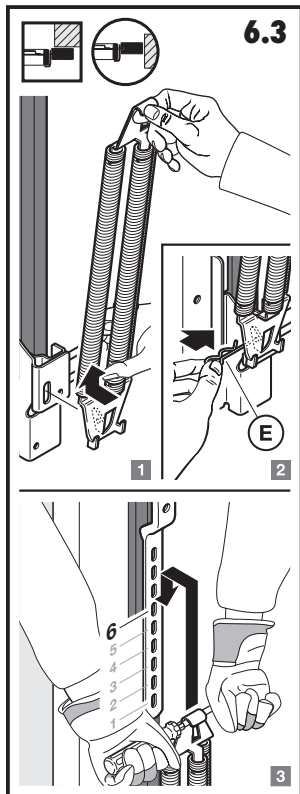

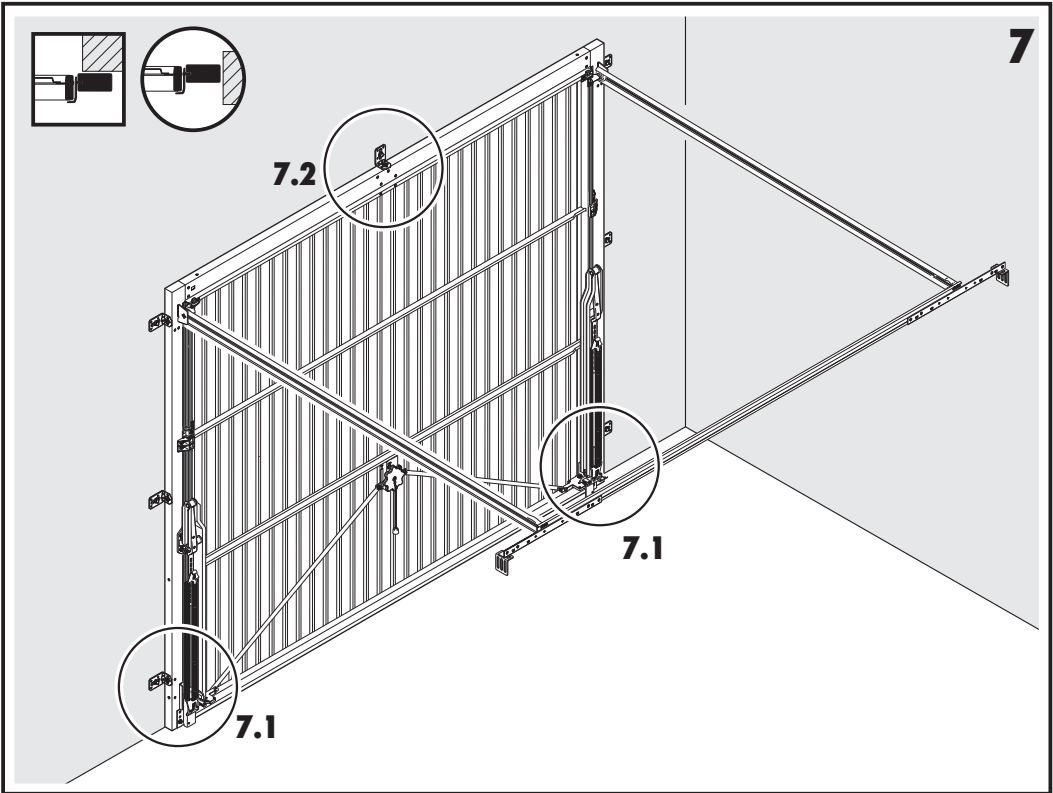

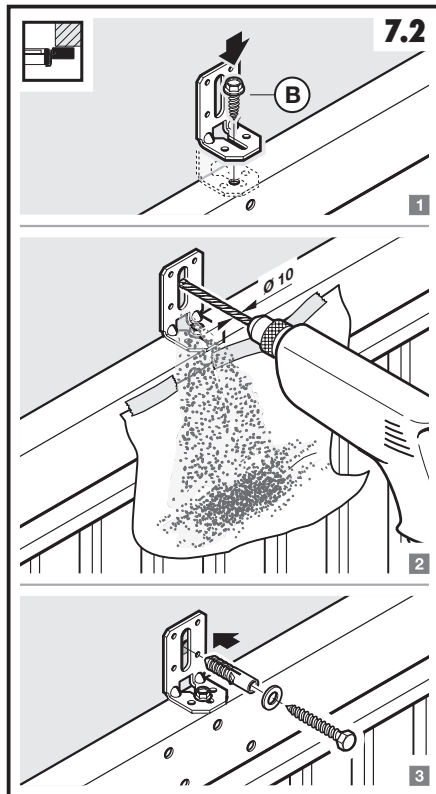
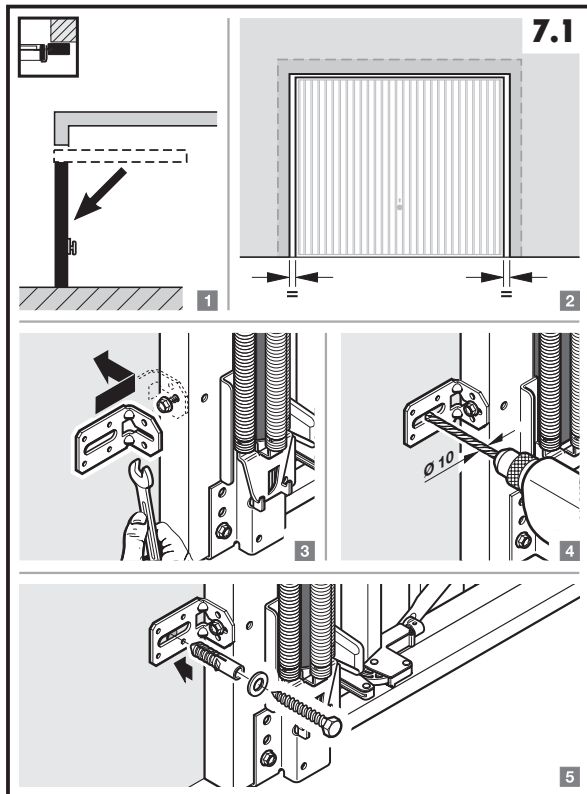

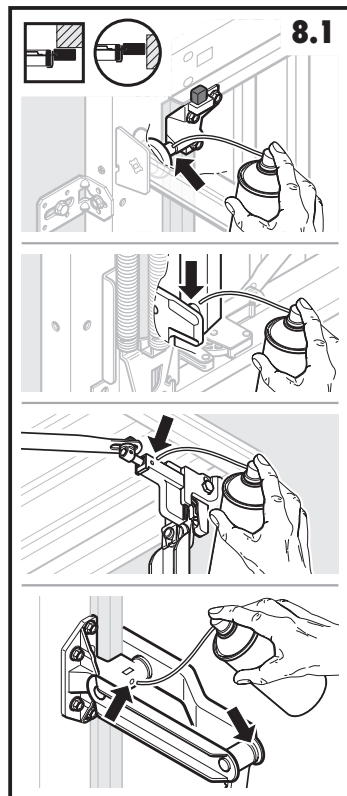
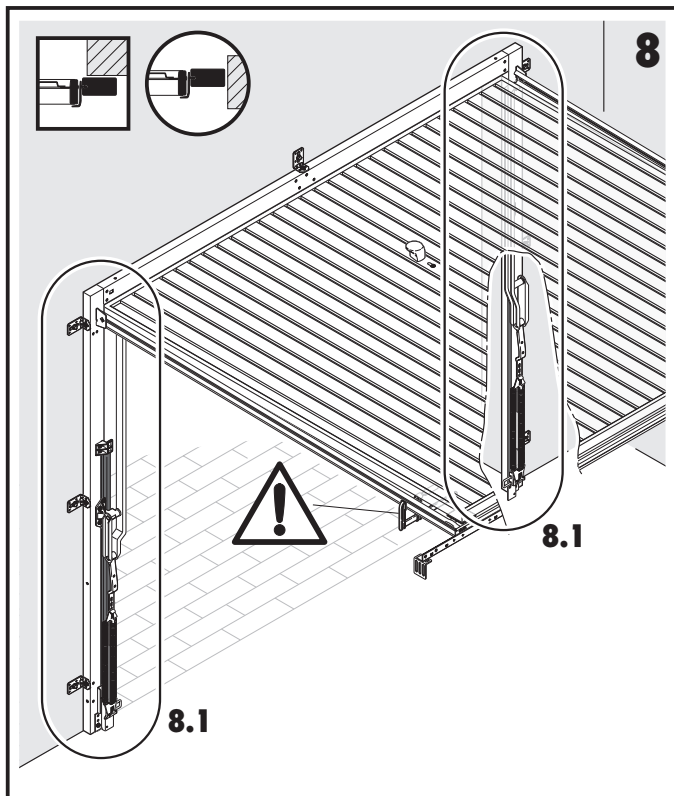

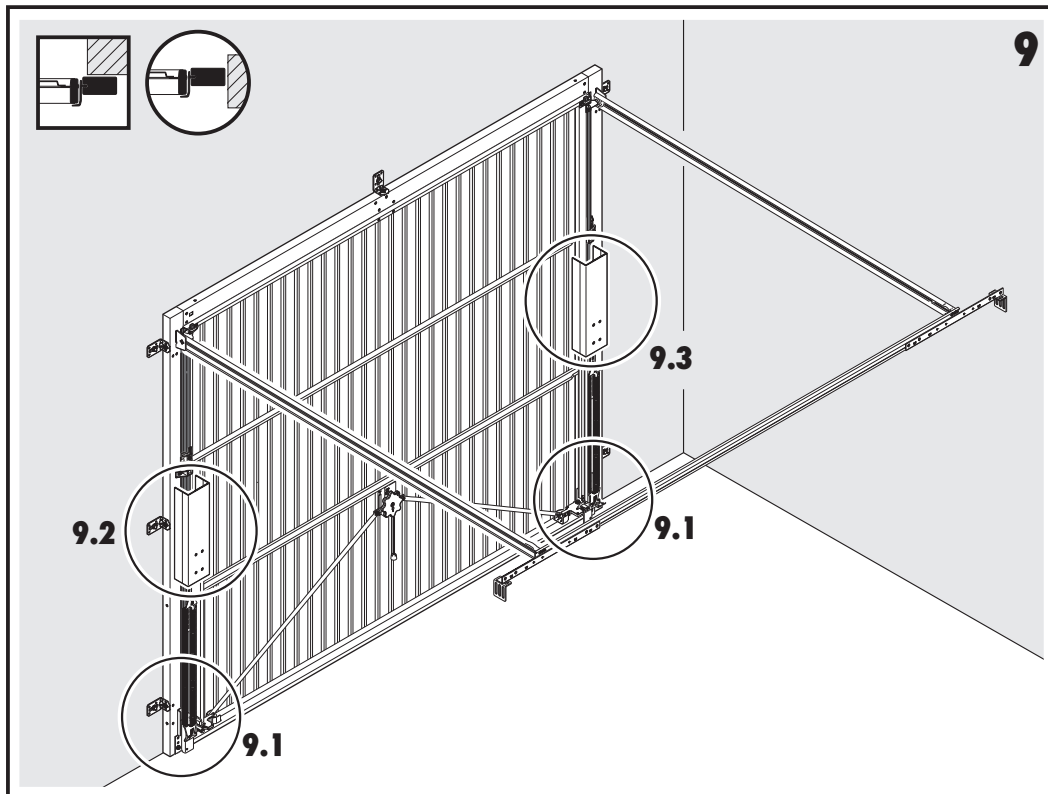

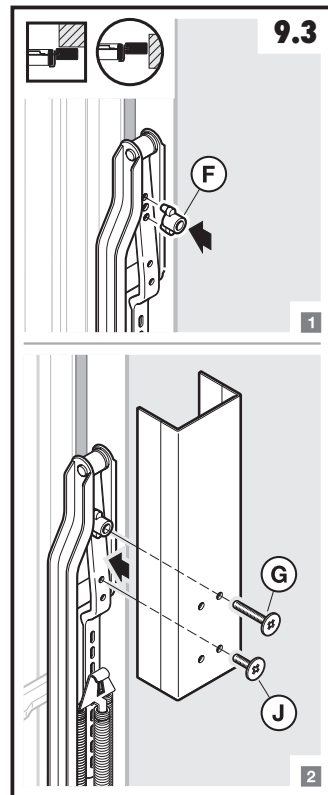
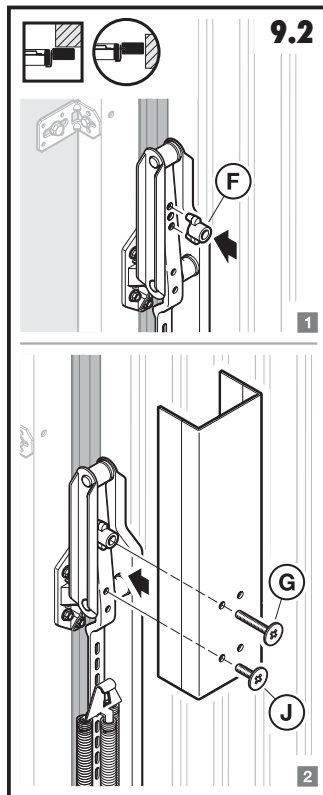
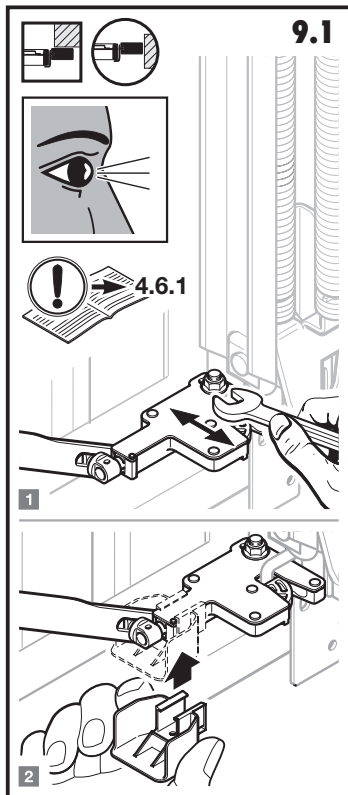

III

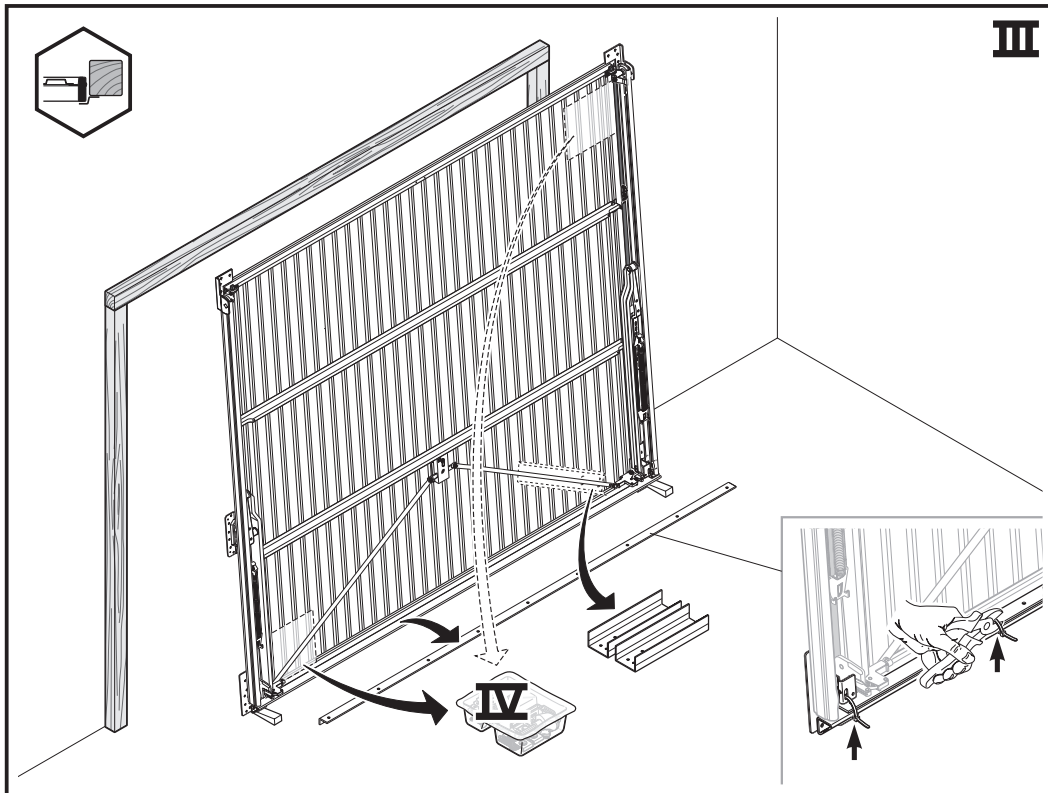

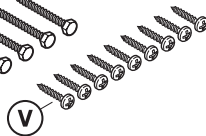
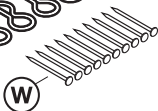
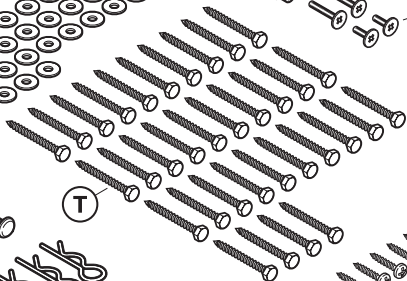
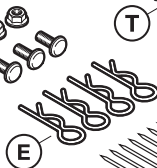
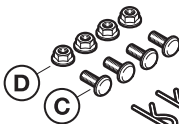
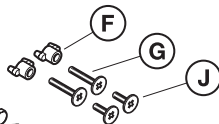
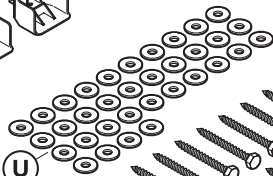
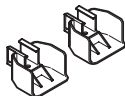
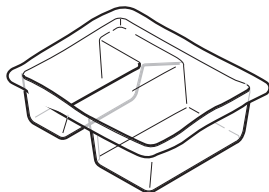
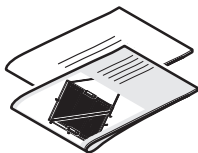

IV

→ 10.1a



→ 10.1b/10.1c

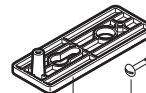
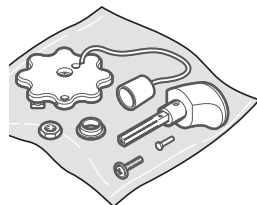

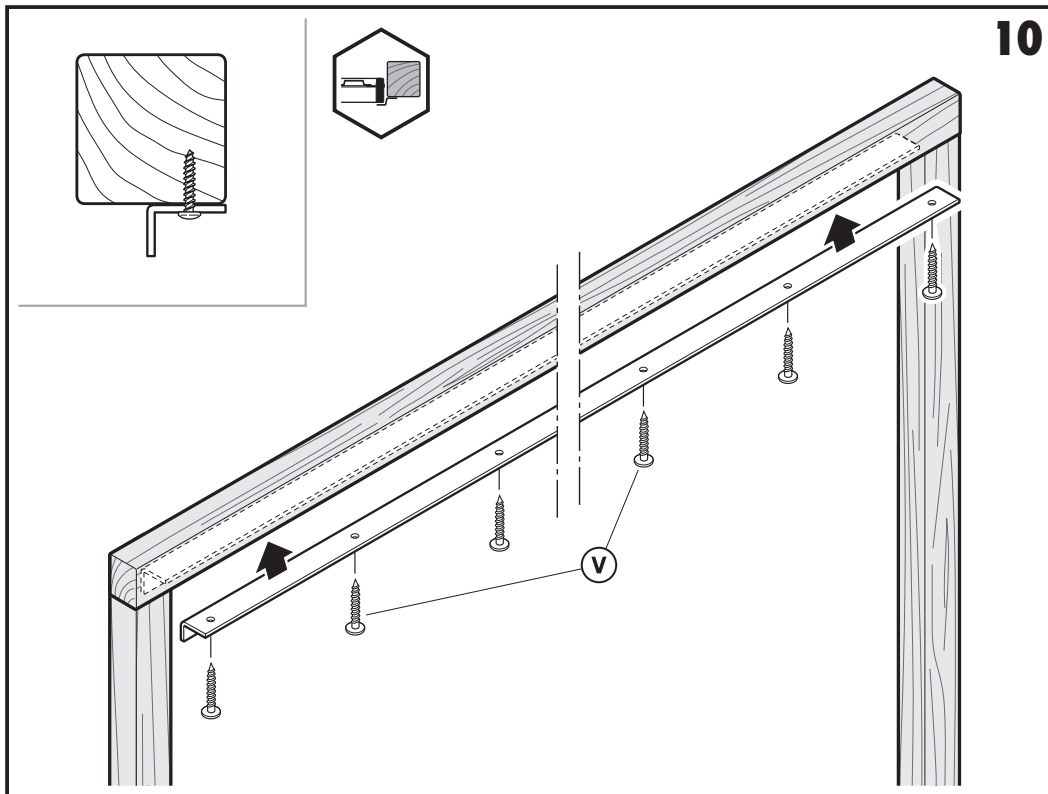



11

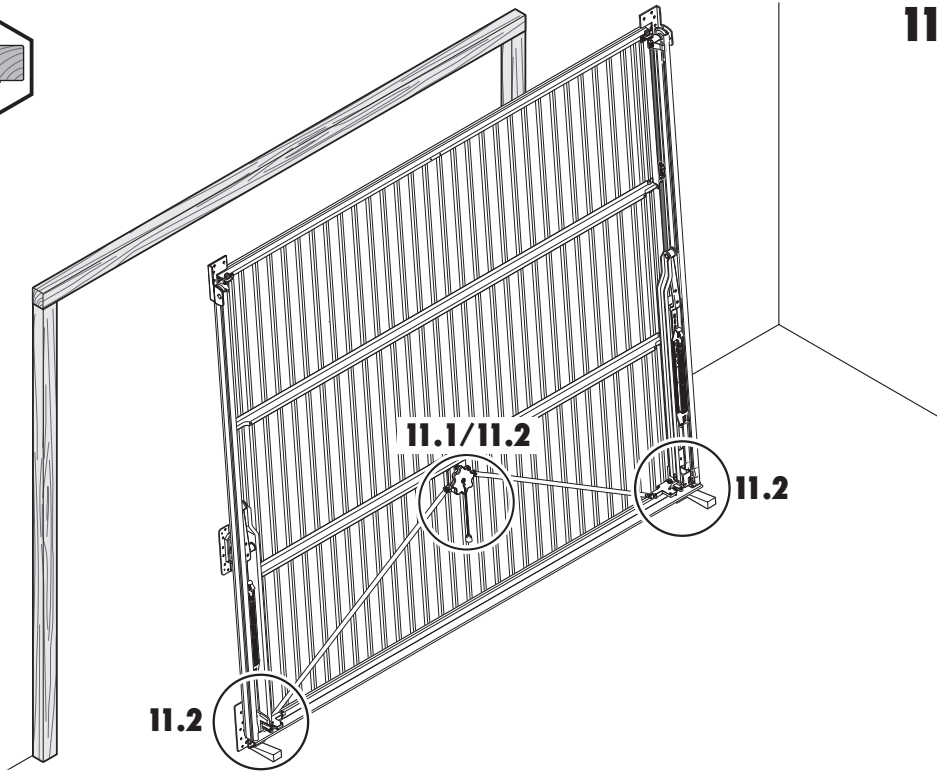

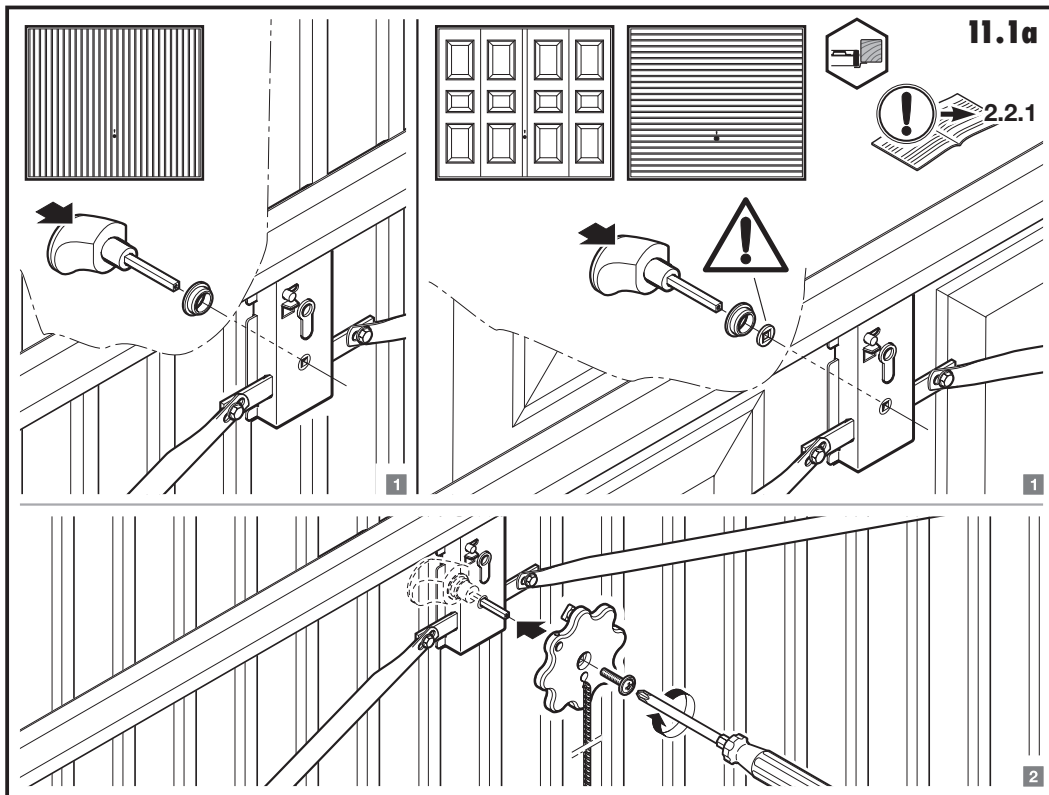

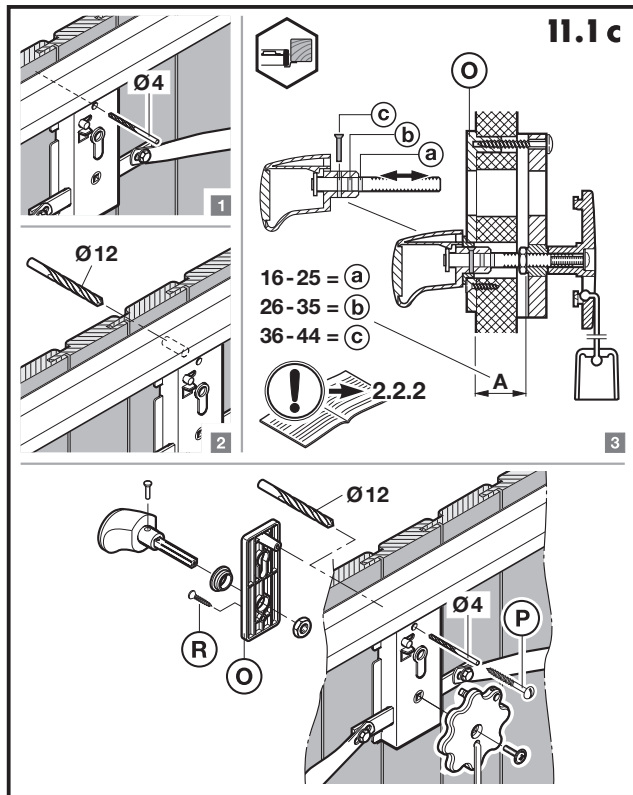
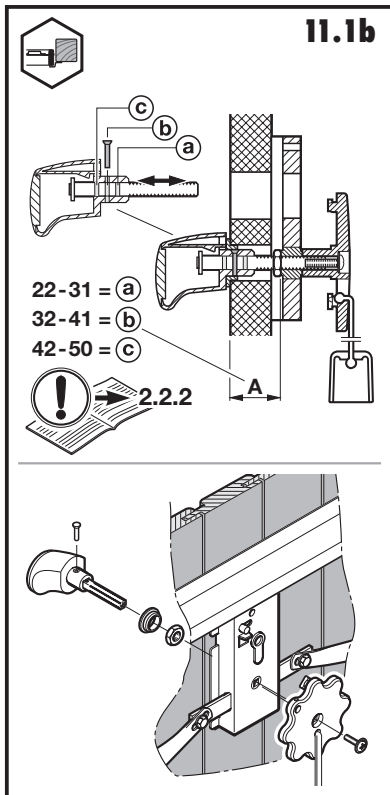

12

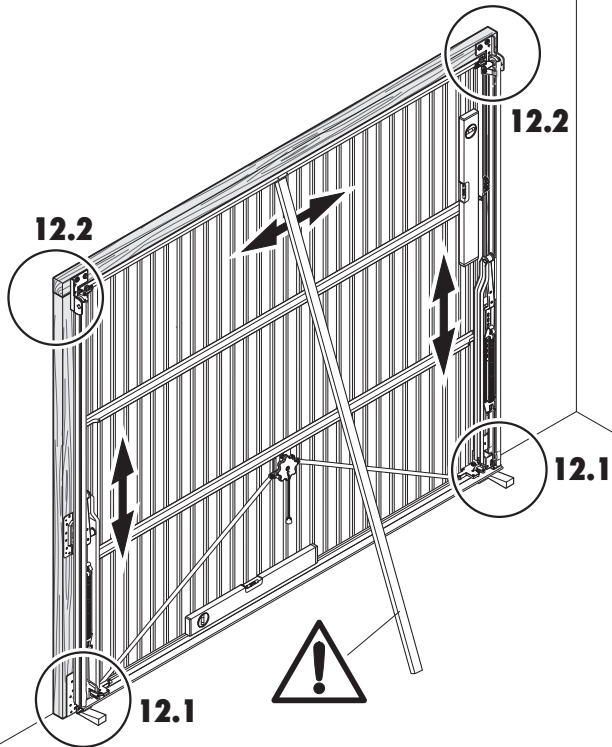

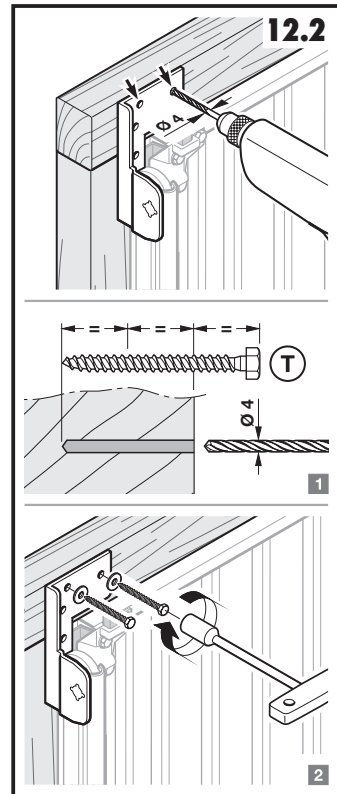
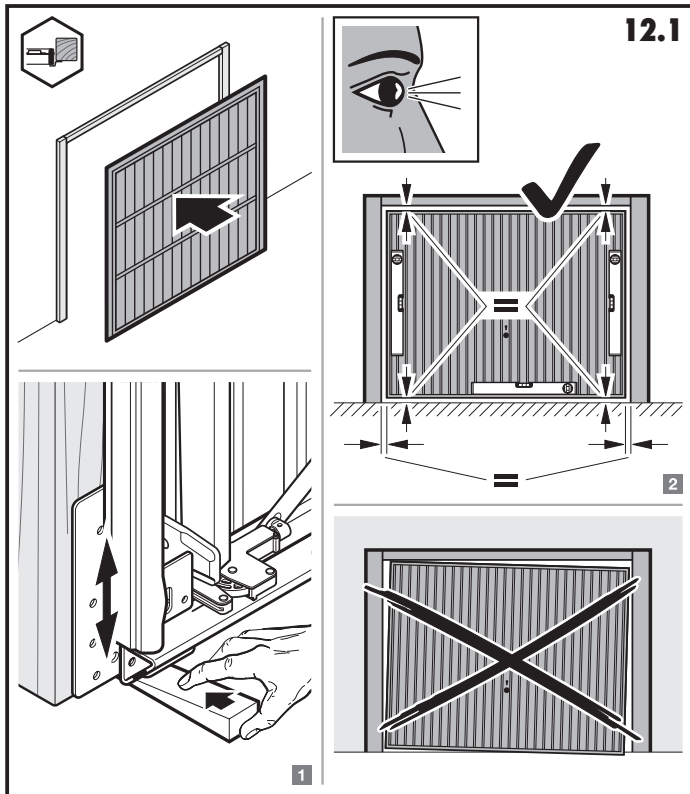

13



13.1/13.2

13.1/13.2

13.1

13.2

13.1

13.2

13.2

13.2



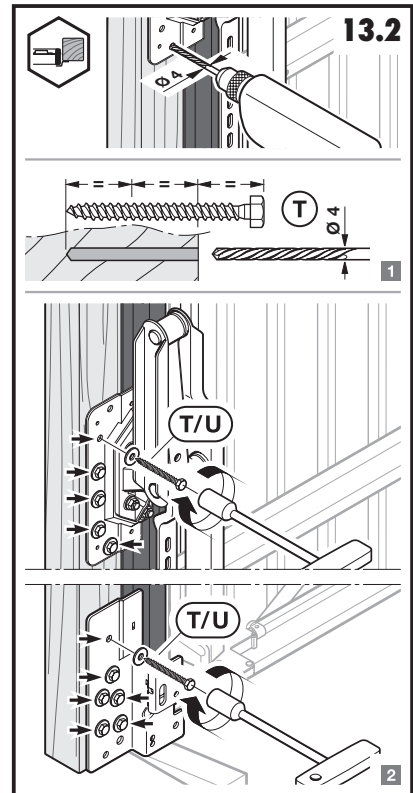
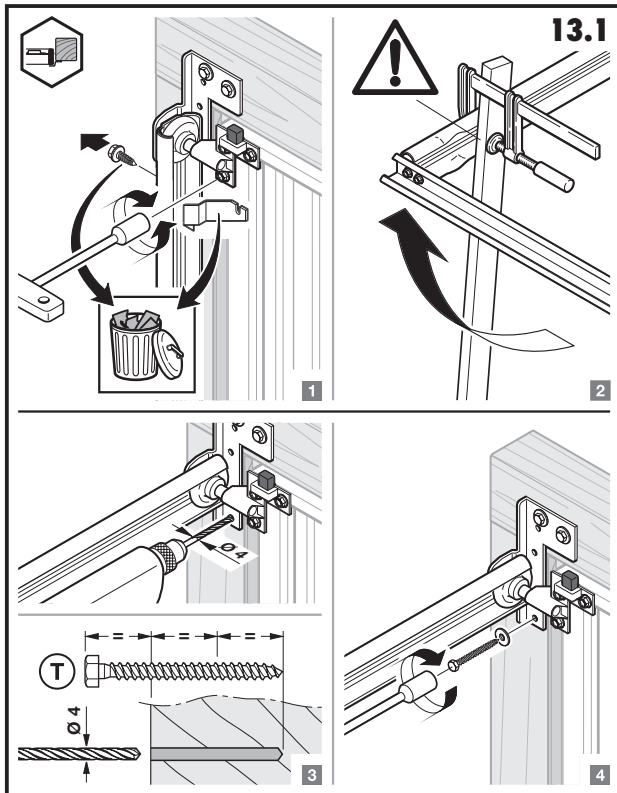

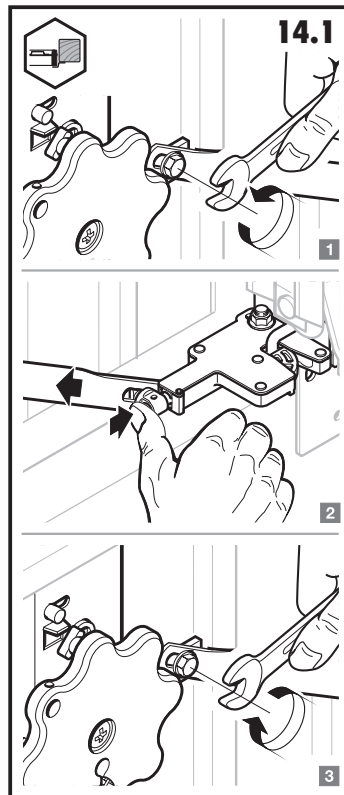
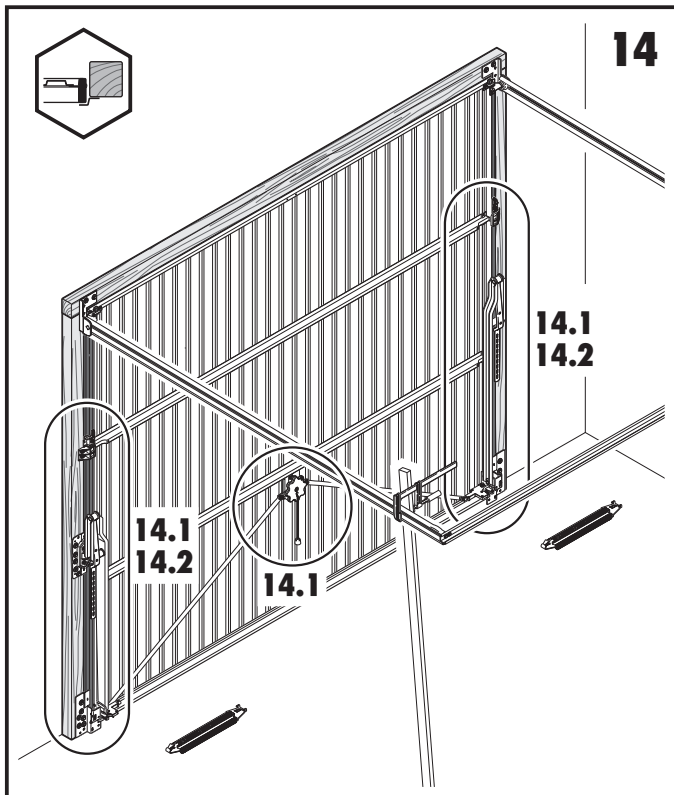

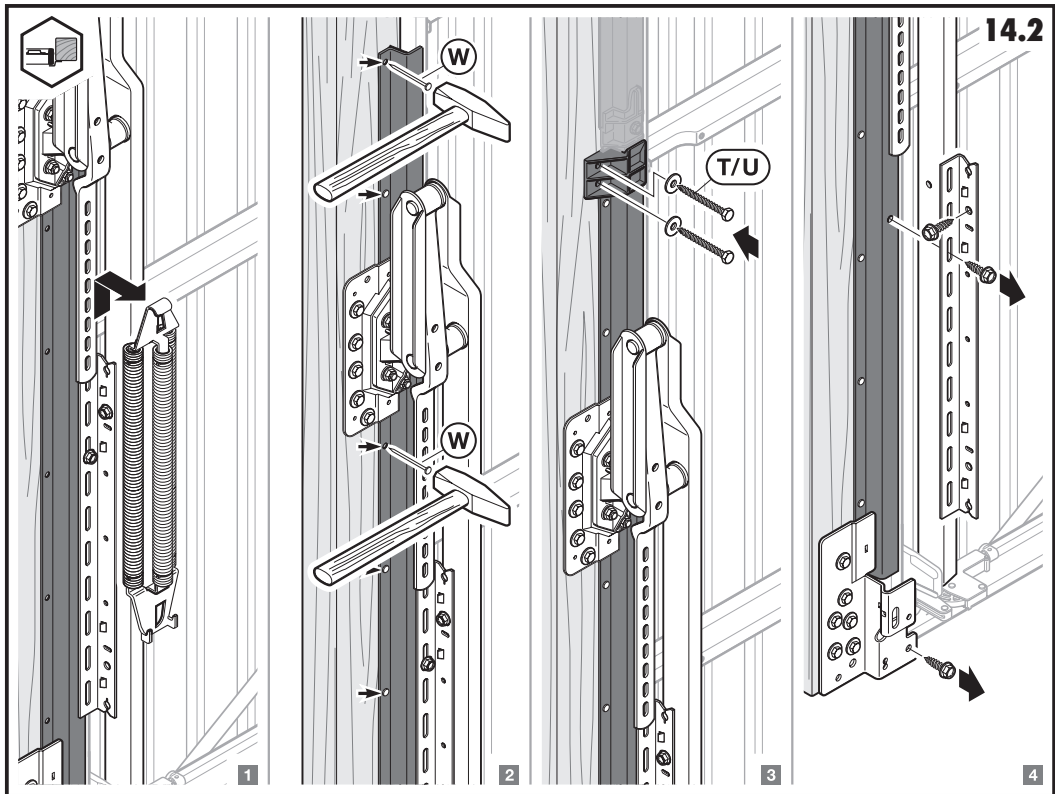

15

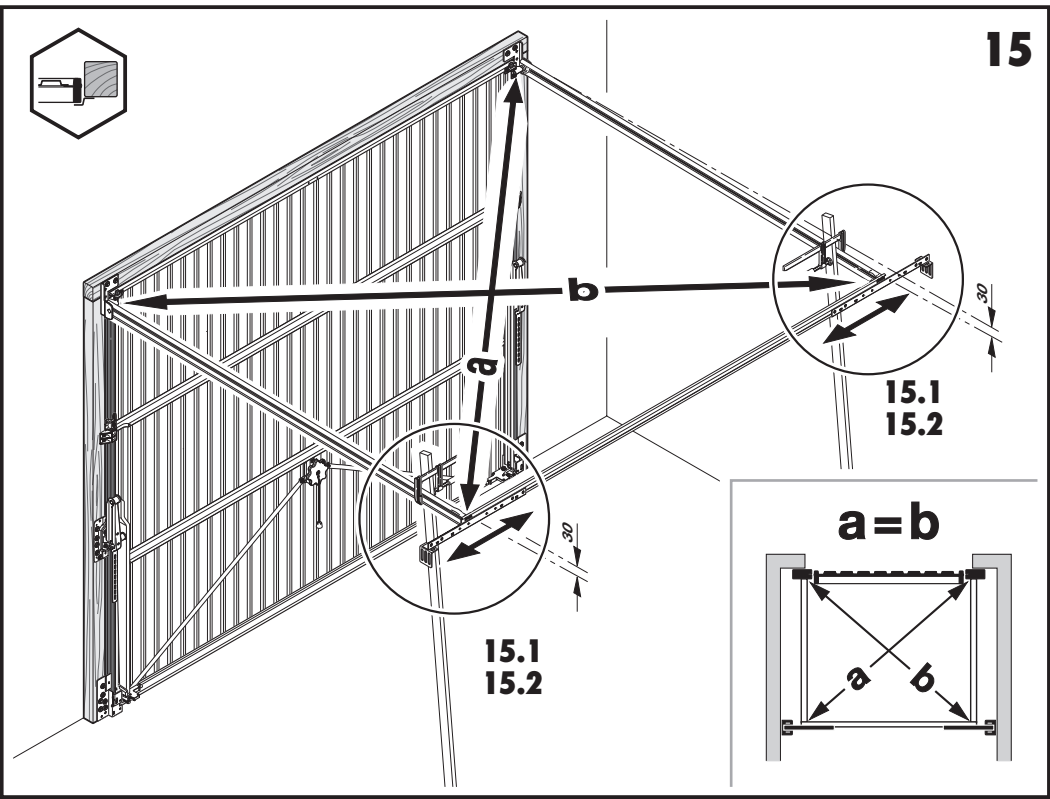

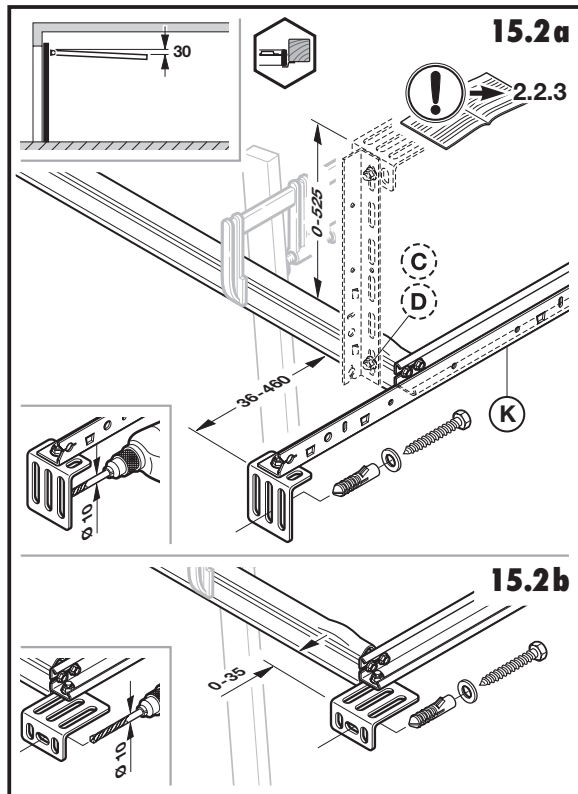
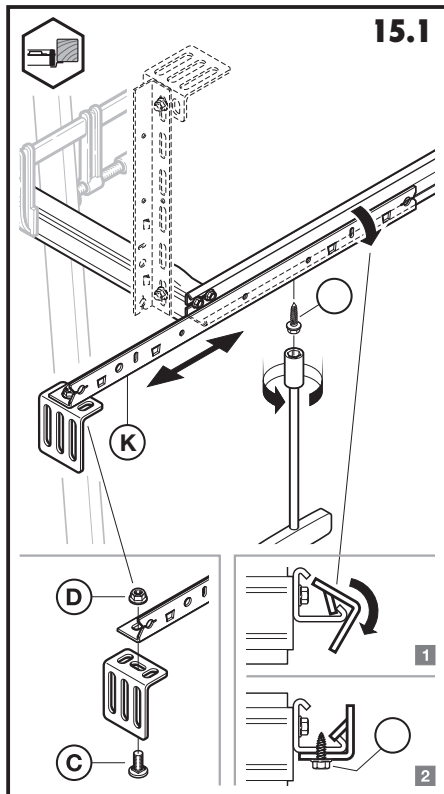

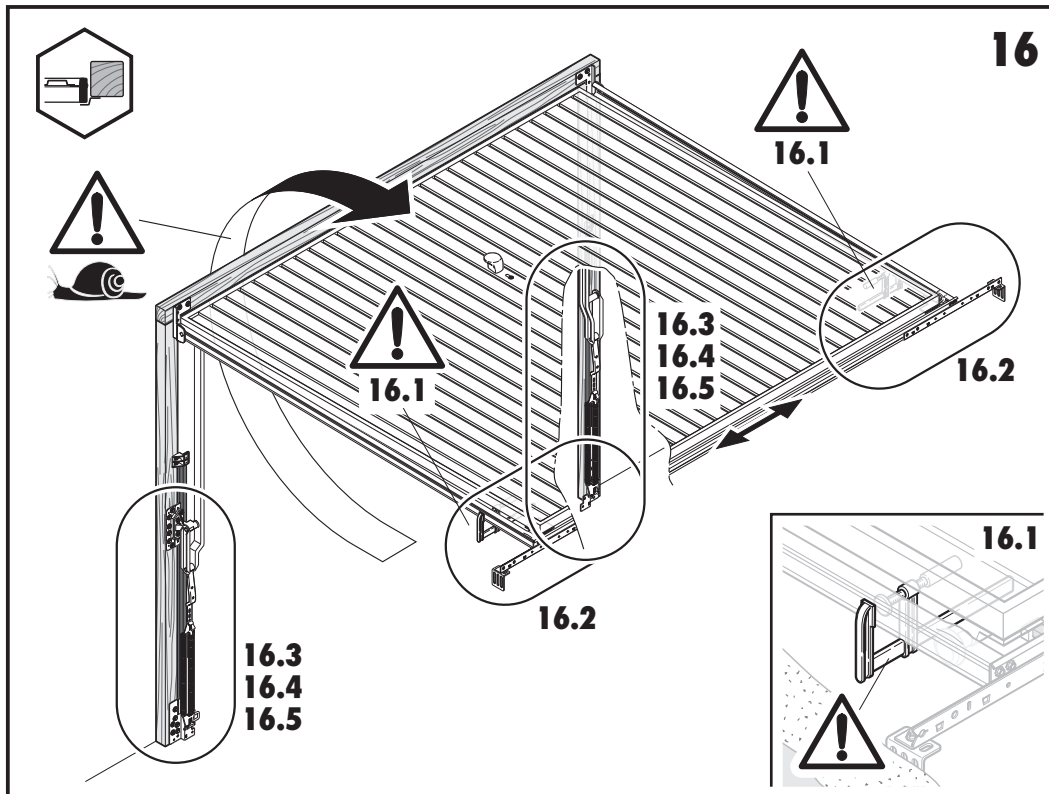

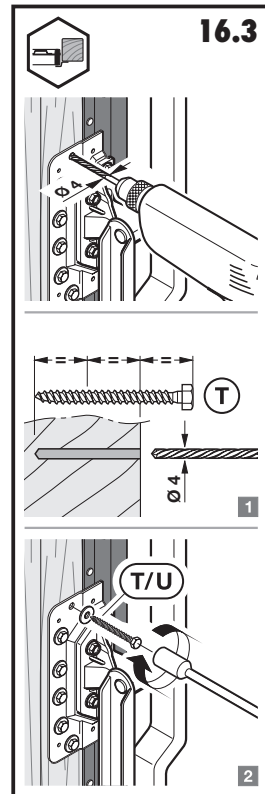
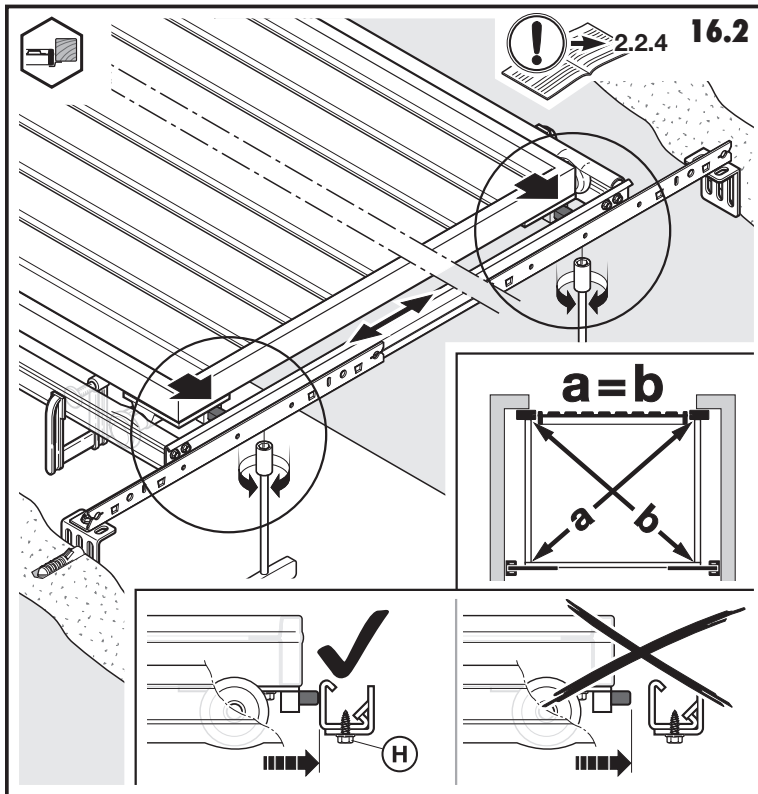

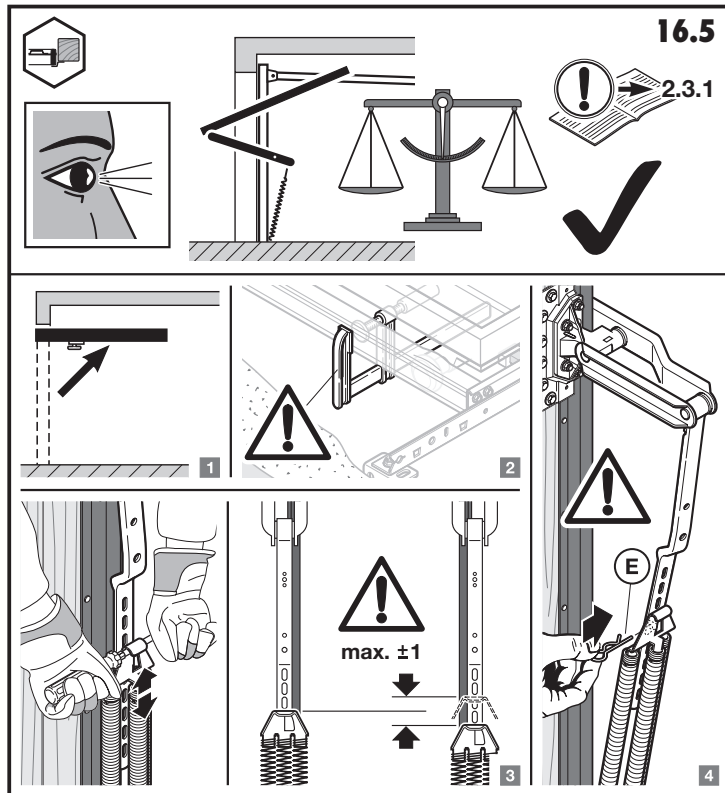
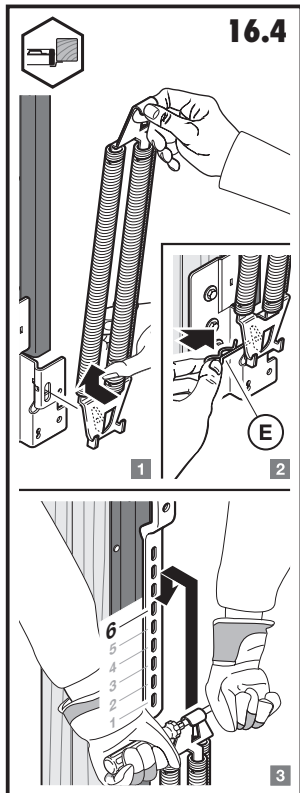

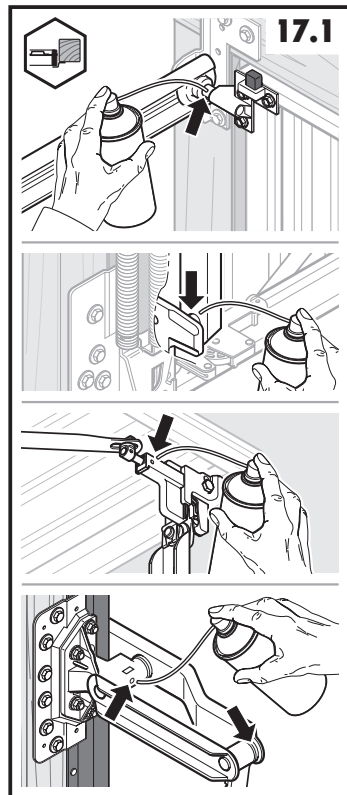
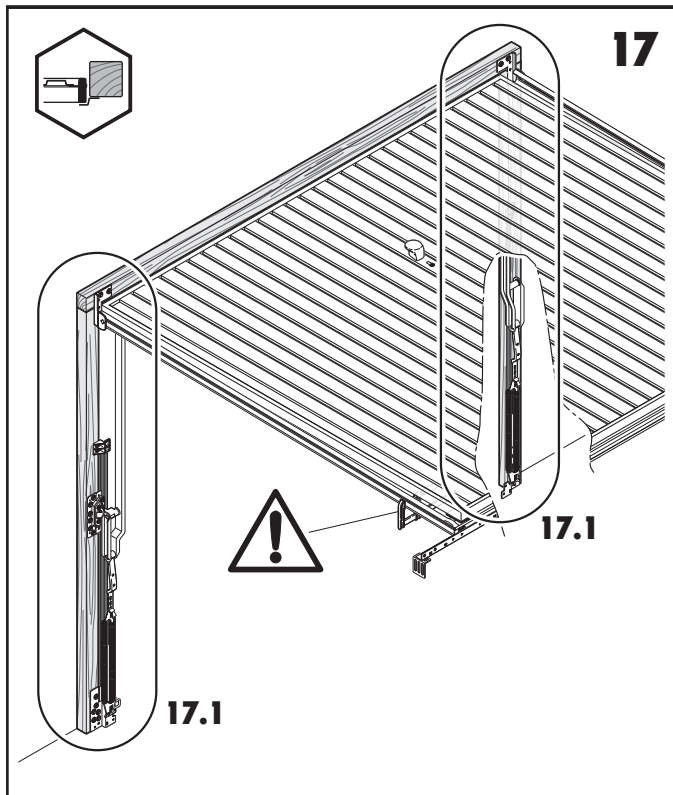

18

